

Data Sheet

# Check valve Type **NRV** and **NRVH**

Version 2

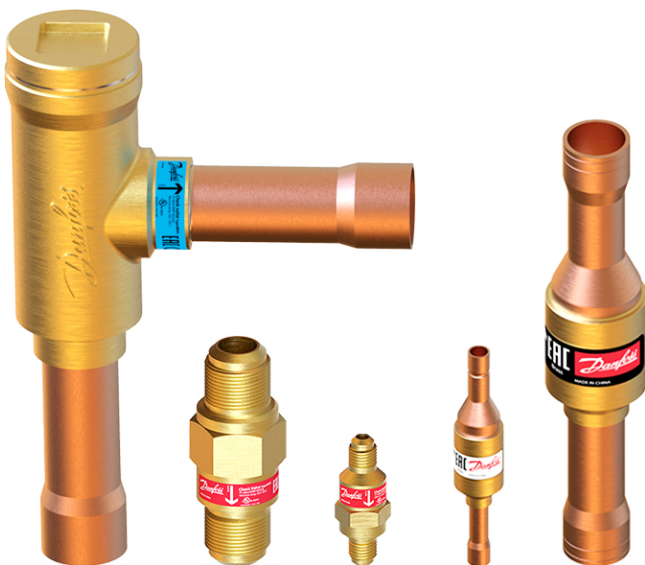

NRV and NRVH piston type check valves are designed for installation in commercial refrigerating systems and in residential or industrial air conditioning plants. They are used to control the unidirectional flow of refrigerant so as to prevent backflow.

**Features:**

- Available in both straightway and angleway versions which is easy to connect
- Hermetic tight design for solder versions with low risk of external leakage
- Built-in damping piston that makes the valves suitable for installation in lines where pulsation can occur, e.g. in the discharge line from the compressor
- NRVH type check valve is with stronger spring and it's recommended to use for compressors in parallel (i.e. power packs) where higher level of pulsation and vibration are expected
- Low pressure drop during operation
- Oversize connections provide flexibility in use

### Functions

NRV/NRVH are used to control the unidirectional flow of refrigerant so as to prevent backflow. When selecting the right Danfoss check valve, it's recommended to use Coolselector which is a Danfoss calculation and selection software. When dimensioning and selecting Danfoss check valves for mounting into the compressor discharge line, it is important to be aware of the following:

The differential pressure across the valve must always be higher than the given minimum pressure drop at which the valve is open. This also applies to lowest capacities for compressor with capacity regulation. NRVH type check valve is with stronger spring and it's recommended to use for compressors in parallel (i.e. power packs) where higher level of pulsation and vibration are expected.

## Applications

Typical applications for NRV and NRVH valves are:

- Cold room
- Heat pump
- VRF
- Chiller

Figure 1: Application Diagram

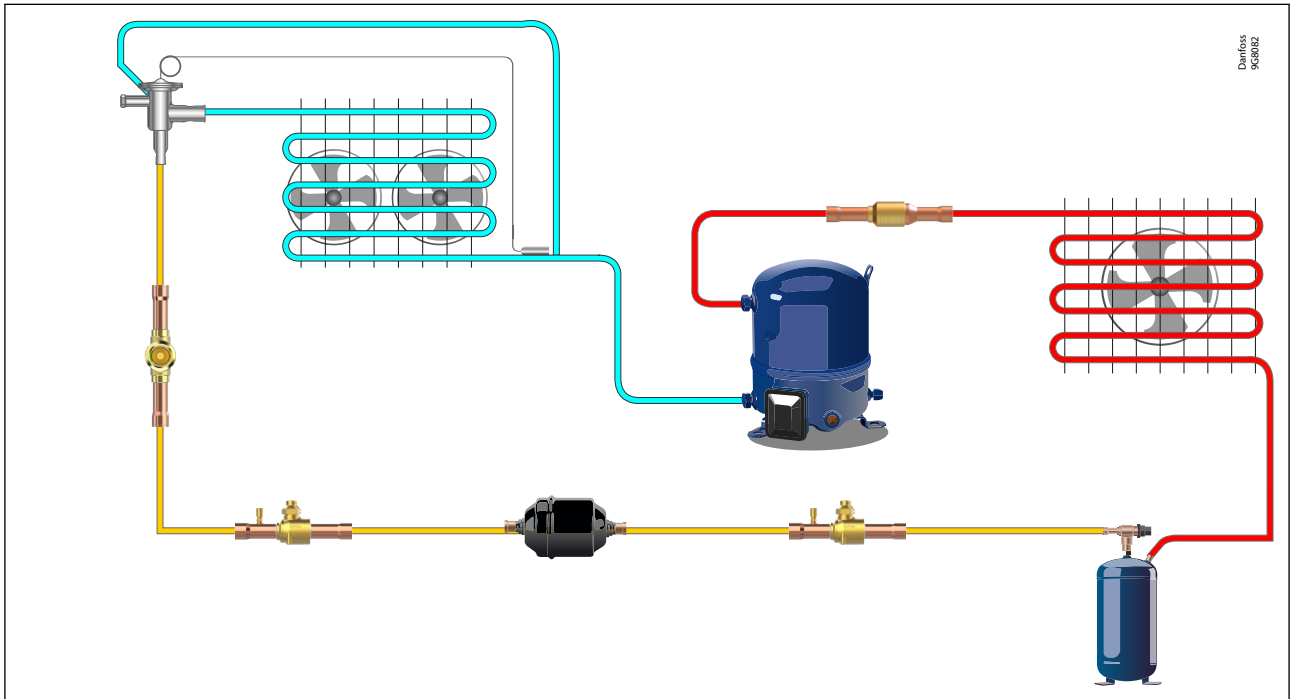

**Media**

**Table 1: Media**

Valve type	Connection type	Max. working pressure	Refrigerants
		(PS/MWP)	
NRV/NRVH 6-19	Straight-way - flare	46 bar / 667 psig	R134a, R22/R407C, R404A/R507, R407A, R407F, R407H, R410A, R448A, R449A, R449B, R450A, R452A, R452B, R454A, R454B, R454C, R455A, R513A, R515B, R516A, R1233zd(E), R1234ze(E), R1234yf
NRV/NRVH 6s-19s <sup>(1)</sup>	Straight-way - solder	49 bar / 710 psig	R134a, R22/R407C, R290, R32, R404A/R507, R407A, R407F, R407H, R410A, R448A, R449A, R449B, R450A, R452A, R452B, R454A, R454B, R454C, R455A, R513A, R515B, R516A, R600, R600a, R1233zd(E), R1234ze(E), R1234yf, R1270
NRV/NRVH 22s-35s <sup>(1)</sup>	Angle-way - solder	46 bar / 667 psig	R134a, R22/R407C, R290 <sup>(2)</sup> , R404A/R507, R407A, R407F, R407H, R410A, R448A, R449A, R449B, R450A, R452A, R452B <sup>(2)</sup> , R454A <sup>(2)</sup> , R454B <sup>(2)</sup> , R454C <sup>(2)</sup> , R455A <sup>(2)</sup> , R513A, R515B, R516A <sup>(2)</sup> , R600 <sup>(2)</sup> , R600a <sup>(2)</sup> , R1233zd(E), R1234ze(E), R1234yf <sup>(2)</sup> , R1270 <sup>(2)</sup>
NRV/NRVH 22s E-35s E <sup>(1)</sup>	Angle-way - solder	49 bar / 710 psig	R290, R32, R452B, R454A, R454B, R454C, R455A, R516A, R600, R600a, R1234ze(E), R1234yf, R1270

<sup>(1)</sup> Oversize connections

<sup>(2)</sup> NRV/NRVH 28s <sup>(1)</sup>-35s <sup>(1)</sup> can be used with flammable refrigerants, without certificate of PED Fluid Group 1, category II

Refrigerant oil	POE, PAG (PVE, PAO)
-----------------	---------------------

**NOTE:**

- For a complete list of approved refrigerants, visit <http://store.danfoss.com/> and search for individual code numbers, where refrigerants are listed as part of product details.
- This product is approved for R290, R32, R452B, R454A, R454B, R454C, R455A, R516A, R600, R600a, R1234ze(E), R1234yf and R1270 by ignition source assessment in accordance to standard EN ISO 80079-36.
- NRV/NRVH is not suitable for oil line application. For detailed information please contact Danfoss.
- Flare/face seal connections are only approved for A1 and A2L refrigerants.
- R32 can only be used for 49bar NRV/NRVH.
- R1234ze can be used for NRV size up to 35s according to the PED category I, Fluid II

## Product specification

### Technical data

**Table 2: Technical data**

Technical data	Values
Max. working pressure	See ordering table
Media temperature range	See ordering table
Environmental transport/storage temperature and humidity	-40 – 65 °C / -40 – 150 °F. Air humidity: RH≤95%
Flow direction	Single flow
Serviceable	No

### Identification

Relevant product data is available on the product and box label. An example of a box label and product label are shown, including an explanation of the content.

**Table 3: Box label & product label (example)**

Box label	Product label

**Table 4: Product and label text**

Position	Inscription	Explanation
Box label; Product label	Check valve	Product name
Box label	020B1010	Code number for ordering
Box label	NRV 6s	Product type; no numeral on product label
Box label	Straightway	Direction
Box label	ODF 1/4 in	Connection size and type
Box label; Product label	PS 49 bar/MWP 710 psig	Max. working pressure in bar and psig
Box label	BE4520C	Code for production place and time (BE = Wuqing, week 45, year 2020, weekday C = Wednesday)
Box label; Product label	MADE IN CHINA	Manufacturing site acc. to EN standards
Box label	EAN code	Barcode for individual code no. identification according to EAN standard
Product label	Min/Max Temp: -50/+155 °C	Media temperature range, min and max.
Product label	Arrow	Flow direction indicator
Box label; Product label	Additional information: Relevant approval authority logos	-

### Design and materials

The pressure of the fluid passing through a refrigeration system opens the valve, while any reverse flow closes the valve.

In NRV/NRVH check valves a sealing disc is activated by the spring to close or open the valve, and the force of the spring determines the differential opening pressure. When the refrigerant flows through the valve and the differential pressure is more than Min. opening pressure, the piston will move to stop face and compress the spring, then the valve will open.

NRV/NRVH valves are equipped with a damping piston for improved performance in lines where pulsations can occur, e.g. in the discharge line from a compressor.

## Check valve, type NRV and NR VH

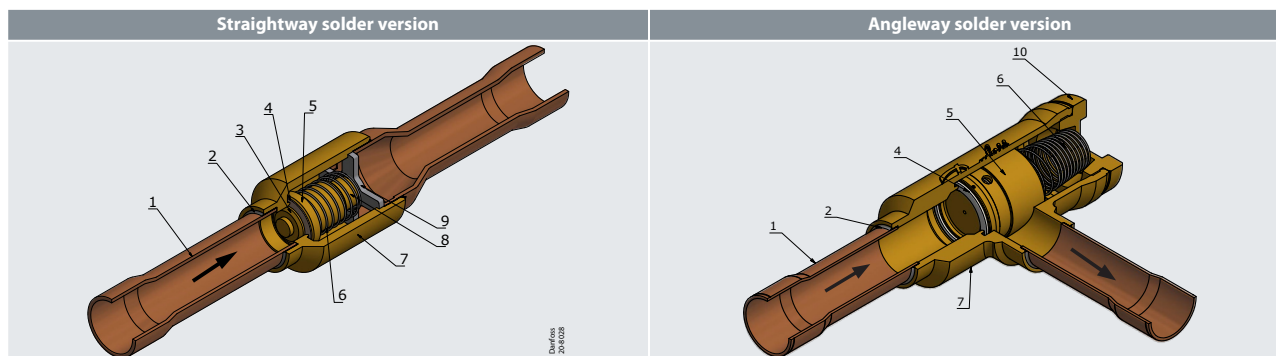

Position	Description	Material
1	Connection tube	Copper
2	Solder ring	Ag alloy
3	Washer	Brass
4	Disk	PTFE with glass fiber
5	Piston	Brass
6	Spring	Stainless steel
7	Valve body	Brass
8	Guide	Brass
9	Stop face	Stainless steel
10	Cover	Brass

### Valve selection based on capacity calculation

As for extended capacity calculations and valve selection based on capacities and refrigerants, please refer to Coolselector®2. Rated and extended capacities are calculated with the Coolselector®2 calculation engine to ARI standards with the ASEREP equations based on laboratory measurements of selected valves.

### Connections

Standard NRV/NRVH versions can be provided with straightway and angleway, connection types Flare or Solder ODF in a wide variety of connection sizes. Solder versions are with extended ends copper connections, flare versions with brass connections.

Table 5: Connections

Direction	Inlet	Outlet	mm connections	Inch connections
Straightway	Flare	Flare	-	¼ in x ¼ in ⅜ in x ⅜ in ½ in x ½ in ⅝ in x ⅝ in ¾ in x ¾ in
Straightway	Solder ODF	Solder ODF	6 mm x 6 mm 10 mm x 10 mm 12 mm x 12 mm 16 mm x 16 mm 18 mm x 18 mm 19 mm x 19 mm 22 mm x 22 mm	¼ in x ¼ in ⅜ in x ⅜ in ½ in x ½ in ⅝ in x ⅝ in ¾ in x ¾ in 7⁄8 in x 7⁄8 in
Angleway	Solder ODF	Solder ODF	22 mm x 22 mm 28 mm x 28 mm 35 mm x 35 mm 42 mm x 42 mm	7⁄8 in x 7⁄8 in 1 1⁄8 in x 1 1⁄8 in 1 3⁄8 in x 1 3⁄8 in 1 5⁄8 in x 1 5⁄8 in

### Dimensions and Weights

We have chosen to show dimensions of the major versions.

You will find downloadable dimension drawings for individual code numbers on Danfoss store as part of the Visuals tab for individual code numbers.

Weights also differ depending on the design of the individual code numbers. Weights are available as part of the technical data for individual code numbers on Danfoss store.

## Flare straightway version

Figure 2: Flare straightway version

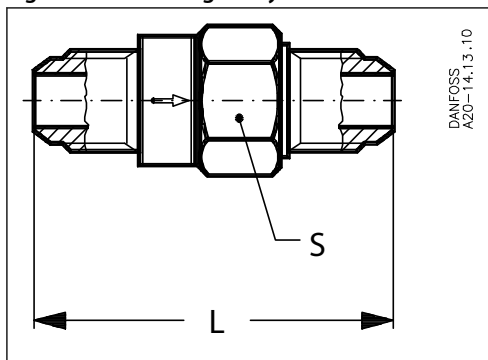

Table 6: Flare straightway version

Type	SAE Flare	Flare	L	Spanner flats S	Net weight
	[in.]	Thread			
NRV 6	¼	7/16-20UNF-2A	55	19	0.072
NRV 10	¾	5/8-18UNF-2A	60	19	0.088
NRV 12	½	¾-16UNF-2A	70	24	0.14
NRV 16	5/8	7/8-14UNF-2A	81	28	0.206
NRV 19	¾	1 1/16-14UNS-2A	95	34	0.344

## Solder straightway version

Figure 3: Solder straightway version

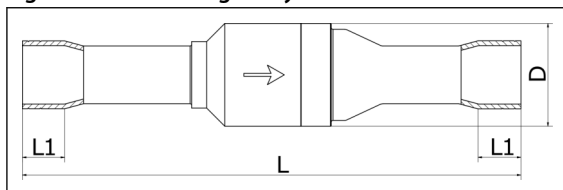

Table 7: Solder straightway version

Type	Connection Size		Connection tolerance	L	L1	øD	Net weight
	[in.]	[mm]					
NRV/NRVH 6s	¼	6	+0.065/+0.155	92	7	18	0.05
NRV/NRVH 6s <sup>(1)</sup>	¾	10	+0.06/+0.13	95	9	18	0.06
NRV/NRVH 10s	¾	10	+0.065/+0.155	109	9	18	0.05
NRV/NRVH 10s <sup>(1)</sup>	½	12	+0.065/+0.155	109	10	18	0.06
NRV/NRVH 12s	½	12	+0.065/+0.155	131	10	22	0.09
NRV/NRVH 12s <sup>(1)</sup>	5/8	16	+0.065/+0.155	131	12	22	0.09
NRV/NRVH 16s	5/8	16	+0.065/+0.155	139	12	28	0.16
NRV/NRVH 16s <sup>(1)</sup>	—	18	+0.065/+0.155	139	14	28	0.17
NRV/NRVH 16s <sup>(1)</sup>	¾	19	+0.065/+0.155	139	14	28	0.17
NRV/NRVH 19s	—	18	+0.065/+0.155	165	14	34	0.27
NRV/NRVH 19s	¾	19	+0.065/+0.155	165	14	34	0.28
NRV/NRVH 19s <sup>(1)</sup>	7/8	22	+0.075/+0.185	165	17	34	0.28

<sup>(1)</sup> Oversize connections

### Solder angleway connection

Figure 4: Solder angleway connection

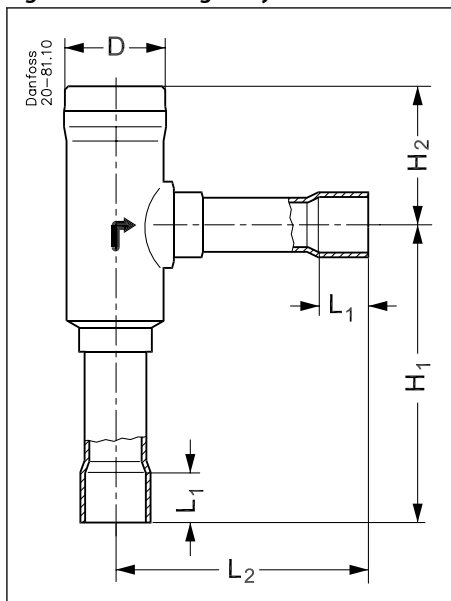

Table 8: Solder angleway connection

Type	Connection size		Connection tolerance [mm]	H <sub>1</sub>	H <sub>2</sub>	L <sub>1</sub>	L <sub>2</sub>	øD	Net weight
	[in.]	[mm]		[mm]	[mm]	[mm]	[mm]	[mm]	[kg]
NRV/NRVH 22s	7/8	22	+0.075/+0.185	94	48	17	87	37	0.584
NRV/NRVH 22s <sup>(1)</sup>	1 1/8	28	+0.075/+0.185	94	48	22	87	37	0.616
NRV/NRVH 28s	1 1/8	28	+0.075/+0.185	141	67	20	123	49	1.330
NRV/NRVH 28s <sup>(1)</sup>	1 3/8	35	+0.09/+0.23	141	67	25	123	49	1.478
NRV/NRVH 35s	1 3/8	35	+0.09/+0.23	141	67	25	123	49	1.400
NRV/NRVH 35s <sup>(1)</sup>	1 5/8	42	+0.09/+0.23	141	67	29	123	49	1.388

<sup>(1)</sup> Oversize connections

## Ordering

NRV/NRVH code numbers described in this data sheet are standard code numbers, i.e. made to stock. Besides code numbers made to stock NRV/NRVH is also made to order. Make to order options include:

- Mechanical connection type
- Mechanical connection size

Multipack contains several items, individually packed, so that customers can purchase 1 item and receive all relevant documentation.

Industrial pack contains several items that are not individually packed. Industrial packs cannot be broken down, and will only contain documentation on pack level, not on item level.

### **Straightway Flare Version without flare nut**



**Table 9: Straightway Flare Version without flare nut**

Valve type	SAE Flare Flare ext. × ext.	Min. OPD Δp <sup>(1)</sup>		Kv <sup>(2)</sup>		Cv <sup>(2)</sup>	Max. working pressure: PS/MWP	Media temperature range	PED category [Fluid Group 1]	PED category [Fluid Group 2]	Multi pack		Industrial pack	
		[in.]	[bar]	[psi]	[m <sup>3</sup> /h]						[gal/min]	Code no.	Qty/ pack	Code no.
NRV 6	1/4	0.07	1.01	0.56	0.65	46 bar / 667 psig	-50 °C - 140 °C / -58 °F - 285 °F	Art. 4.3	Art. 4.3	020-1040	25	020-0138	140	
NRV 10	3/8	0.07	1.01	1.2	1.39					020-1041	25	-	-	
NRV 12	1/2	0.05	0.72	2.05	2.37					020-1042	25	-	-	
NRV 16	5/8	0.05	0.72	3.6	4.16					020-1043	25	-	-	
NRV 19	3/4	0.05	0.72	5.5	6.36					020-1044	24	-	-	

<sup>(1)</sup> Δ p = Minimum Opening Pressure Differential

<sup>(2)</sup> The Kv / Cv is the flow of water in [m<sup>3</sup>/h – gal/min] at a pressure drop across valve of 1 bar/14.5 psig, ρ = 1000 kg/m<sup>3</sup> / 62.4 lb/ft<sup>3</sup>

### Angleway Solder ODF Version, PS = 46 bar



Table 10: Angleway Solder ODF Version, PS = 46 bar

Valve type	Connection Solder ODF × ODF		Min. OPD Δp <sup>(2)</sup>		Kv <sup>(3)</sup>	Cv <sup>(3)</sup>	Max. working pressure: PS/MWP	Media temperature range	PED category [Fluid Group 1]	PED category [Fluid Group 2]	Multi pack		Industrial pack	
	[in.]	[mm]	[bar]	[psi]							[m3/h]	[gal/min]	Code no.	Qty/pack
NRV 22s	7/8	22	0.04	0.58	8.5	9.83	46 bar / 667 psig	-50 °C - 140 °C / -58 °F - 285 °F	Art. 4.3	Art. 4.3	020-1020	18	020-1152	12
NRVH 22s	7/8	22	0.30	4.35	8.5	9.83					020-1032	18	020-0129	12
NRV 22s <sup>(1)</sup>	1 1/8	-	0.04	0.58	8.5	9.83					020-1060	18	-	-
	-	28	0.04	0.58	8.5	9.83					020-1055	18	-	-
NRVH 22s <sup>(1)</sup>	1 1/8	-	0.30	4.35	8.5	9.83					020-1072	18	-	-
	-	28	0.30	4.35	8.5	9.83					020-1067	18	-	-
NRV 28s	1 1/8	-	0.04	0.58	16.5	19.07					020-1021	6	020-0126	12
	-	28	0.04	0.58	16.5	19.07					020-1025	6	020-1153	12
NRVH 28s	1 1/8	-	0.30	4.35	16.5	19.07					020-1029	6	-	-
	-	28	0.30	4.35	16.5	19.07					020-1033	6	020-0131	12
NRV 28s <sup>(1)</sup>	1 3/8	35	0.04	0.58	16.5	19.07					020-1056	6	-	-
NRVH 28s <sup>(1)</sup>	1 3/8	35	0.30	4.35	16.5	19.07					020-1068	6	-	-
NRV 35s	1 3/8	35	0.04	0.58	29	33.52					020-1026	6	020-1154	12
NRVH 35s	1 3/8	35	0.30	4.35	29	33.52					020-1034	6	020-0127	12
NRV 35s <sup>(1)</sup>	1 5/8	-	0.04	0.58	29	33.52					020-1061	6	-	-
	-	42	0.04	0.58	29	33.52					020-1027	6	-	-
NRVH 35s <sup>(1)</sup>	1 5/8	-	0.30	4.35	29	33.52	020-1073	6	-	-				
	-	42	0.30	4.35	29	33.52	020-1035	6	-	-				

<sup>(1)</sup> Oversize connections

<sup>(2)</sup> Δ p =Minimum Opening Pressure Differential

<sup>(3)</sup> The Kv / Cv is the flow of water in [m3/h – gal/min] at a pressure drop across valve of 1 bar/14.5 psig, ρ = 1000 kg/m3 / 62.4 lb/ft3

### Angleway Solder ODF Version, PS = 49 bar

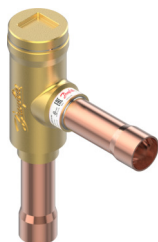

Table 11: Angleway Solder ODF Version, PS = 49 bar

Valve type	Connection Solder ODF × ODF		Min. OPD $\Delta p$ <sup>(2)</sup>		Kv <sup>(3)</sup> [m <sup>3</sup> /h]	Cv <sup>(3)</sup> [gal/min]	Max. working pressure: PS/MWP	Media temperature range	PED category [Fluid Group 1]	PED category [Fluid Group 2]	Multi pack		Industrial pack	
	[in.]	[mm]	[bar]	[psi]							Code no.	Qty/pack	Code no.	Qty/pack
NRV 22s E	7/8	22	0.04	0.58	8.5	9.83	49 bar / 710 psig	-50 °C - 155 °C / -58 °F - 311 °F	Art. 4.3	-	020-3020	18	-	-
NRVH 22s E	7/8	22	0.30	4.35	8.5	9.83					020-3032	18	-	-
NRV 22s E <sup>(1)</sup>	1 1/8	-	0.04	0.58	8.5	9.83					020-3060	18	-	-
		28	0.04	0.58	8.5	9.83					020-3055	18	-	-
NRVH 22s E <sup>(1)</sup>	1 1/8	-	0.30	4.35	8.5	9.83					020-3072	18	-	-
		28	0.30	4.35	8.5	9.83					020-3067	18	-	-
NRV 28s E	1 1/8	-	0.04	0.58	16.5	19.07					020-3021	6	-	-
		28	0.04	0.58	16.5	19.07					020-3025	6	-	-
NRVH 28s E	1 1/8	-	0.30	4.35	16.5	19.07					020-3029	6	-	-
		28	0.30	4.35	16.5	19.07					020-3039	6	-	-
NRV 28s E <sup>(1)</sup>	1 3/8	35	0.04	0.58	16.5	19.07					020-3056	6	-	-
NRVH 28s E <sup>(1)</sup>	1 3/8	35	0.30	4.35	16.5	19.07					020-3068	6	-	-
NRV 35s E	1 3/8	35	0.04	0.58	29	33.52			020-3026	6	-	-		
NRVH 35s E	1 3/8	35	0.30	4.35	29	33.52			020-3036	6	-	-		
NRV 35s E <sup>(1)</sup>	1 5/8	-	0.04	0.58	29	33.52			020-3061	6	-	-		
		42	0.04	0.58	29	33.52			020-3027	6	-	-		
NRVH 35s E <sup>(1)</sup>	1 5/8	-	0.30	4.35	29	33.52			020-3073	6	-	-		
		42	0.30	4.35	29	33.52			020-3035	6	-	-		

<sup>(1)</sup> Oversize connections

<sup>(2)</sup>  $\Delta p$  = Minimum Opening Pressure Differential

<sup>(3)</sup> The Kv / Cv is the flow of water in [m<sup>3</sup>/h – gal/min] at a pressure drop across valve of 1 bar/14.5 psig,  $\rho = 1000 \text{ kg/m}^3 / 62.4 \text{ lb/ft}^3$

### Straightway Solder ODF Version



Table 12: Straightway Solder ODF Version

Valve type	Connection Solder ODF x ODF		Min. OPD $\Delta p$ <sup>(2)</sup>		Kv <sup>(3)</sup>	Cv <sup>(3)</sup>	Max. working pressure: PS/MWP	Media temperature range	PED category [Fluid Group 1]	PED category [Fluid Group 2]	Multi pack		Industrial pack	
	[in.]	[mm]	[bar]	[psi]	[m <sub>3</sub> /h]	[gal/min]					Code no.	Qty/pack	Code no.	Qty/pack
NRV 6s	1/4	-	0.04	0.58	0.67	0.77	49 bar / 710 psig	-50 °C - 155 °C / -58 °F - 311 °F	Art. 4.3	Art. 4.3	020B1010	25	020B0125	88
	-	6	0.04	0.58	0.67	0.77					020B1014	25	020B1156	88
NRV 6s <sup>(1)</sup>	3/8	-	0.04	0.58	0.67	0.77					020B1057	25	020B1191	88
	-	10	0.04	0.58	0.67	0.77					020B1050	25	020B1082	88
NRVH 6s <sup>(1)</sup>	3/8	-	0.20	2.90	0.67	0.77					020B1069	25	-	-
	-	10	0.20	2.90	0.67	0.77					020B1062	25	-	-
NRV 10s	3/8	-	0.04	0.58	1.64	1.90					020B1011	25	020B1168	40
	-	10	0.04	0.58	1.64	1.90					020B1015	25	020B0136	88
NRVH 10s	1/2	-	0.20	2.90	1.64	1.90					020B1046	25	-	-
	-	12	0.20	2.90	1.64	1.90					020B1036	25	020B0132	88
NRV 10s <sup>(1)</sup>	1/2	-	0.04	0.58	1.64	1.90					020B1058	25	020B0165	40
	-	12	0.04	0.58	1.64	1.90					020B1051	25	020B0161	40
NRVH 10s <sup>(1)</sup>	1/2	-	0.20	2.90	1.64	1.90					020B1070	25	-	-
	-	12	0.20	2.90	1.64	1.90					020B1063	25	-	-
NRV 12s	1/2	-	0.02	0.29	2.50	2.89					020B1012	24	020B1155	40
	-	12	0.02	0.29	2.50	2.89					020B1016	24	020B0137	40
NRVH 12s	1/2	-	0.20	2.90	2.50	2.89					020B1039	24	020B1239	40
	-	12	0.20	2.90	2.50	2.89					020B1037	24	020B0133	40
NRV 12s <sup>(1)</sup>	5/8	16	0.02	0.29	2.50	2.89					020B1052	24	020B0162	54
NRVH 12s <sup>(1)</sup>	5/8	16	0.20	2.90	2.50	2.89					020B1064	24	-	-
NRV 16s	5/8	16	0.02	0.29	4.00	4.62					020B1018	24	020B1150	54
NRVH 16s	5/8	16	0.20	2.90	4.00	4.62					020B1038	24	020B0134	54
NRV 16s <sup>(1)</sup>	-	18	0.02	0.29	4.00	4.62					020B1053	24	-	-
NRVH 16s <sup>(1)</sup>	-	18	0.20	2.90	4.00	4.62					020B1065	24	-	-
NRV 16s <sup>(1)</sup>	3/4	19	0.02	0.29	4.00	4.62					020B1059	24	-	-
NRVH 16s <sup>(1)</sup>	3/4	19	0.20	2.90	4.00	4.62					020B1071	24	-	-
NRV 19s	-	18	0.02	0.29	6.50	7.51					020B1017	28	-	-
NRVH 19s	-	18	0.14	2.03	6.50	7.51					020B1008	28	-	-
NRV 19s	3/4	19	0.02	0.29	6.50	7.51					020B1019	28	-	-
NRVH 19s	3/4	19	0.14	2.03	6.50	7.51					020B1023	28	-	-
NRV 19s <sup>(1)</sup>	7/8	22	0.02	0.29	6.50	7.51	020B1054	28	020B1091	54				
NRVH 19s <sup>(1)</sup>	7/8	22	0.14	2.03	6.50	7.51	020B1066	28	-	-				

<sup>(1)</sup> Oversize connections

<sup>(2)</sup>  $\Delta p$  = Minimum Opening Pressure Differential

<sup>(3)</sup> The Kv / Cv is the flow of water in [m<sup>3</sup>/h – gal/min] at a pressure drop across valve of 1 bar/14.5 psig,  $\rho$  = 1000 kg/m<sup>3</sup> / 62.4 lb/ft<sup>3</sup>

**Certificates, declarations, and approvals**

The list contains all certificates, declarations, and approvals for this product type. Individual code number may have some or all of these approvals, and certain local approvals may not appear on the list.

Some approvals may change over time. You can check the most current status at danfoss.com or contact your local Danfoss representative if you have any questions.

**Certificates, declarations, and approvals**



**Table 13: Certificates, declarations, and approvals**

File name	Document type	Document topic	Approval authority
Д-DK.БЛ08.В.03644	EAC Declaration	Machinery & Equipment	EAC RU
Д-DK.РА01.В.72124_20	EAC Declaration	PED	EAC RU
033F4001.AE	Manufacturers Declaration	PED	Danfoss
033F4002.AE	EU Declaration	PED	Danfoss
033F4006	Manufacturers Declaration	China RoHS	Danfoss
033F4010	Manufacturers Declaration	RoHS	Danfoss
033F4017.AA	Manufacturers Declaration	EN ISO 14903:2017 Level A1/B1	Danfoss
UA.089.D.00188-17	UA Declaration	PED	LLC CDC EURO TYSK
UA.TR-089.0993-17	Pressure - Safety Certificate	PED	LLC CDC EURO TYSK
UL SA7200	Mechanical - Safety Certificate	UL	UL

## Online support

Danfoss offers a wide range of support along with our products, including digital product information, software, mobile apps, and expert guidance. See the possibilities below.

### The Danfoss Product Store



The Danfoss Product Store is your one-stop shop for everything product related—no matter where you are in the world or what area of the cooling industry you work in. Get quick access to essential information like product specs, code numbers, technical documentation, certifications, accessories, and more.

Start browsing at [store.danfoss.com](https://store.danfoss.com).

### Find technical documentation



Find the technical documentation you need to get your project up and running. Get direct access to our official collection of data sheets, certificates and declarations, manuals and guides, 3D models and drawings, case stories, brochures, and much more.

Start searching now at [www.danfoss.com/en/service-and-support/documentation](https://www.danfoss.com/en/service-and-support/documentation).

### Danfoss Learning



Danfoss Learning is a free online learning platform. It features courses and materials specifically designed to help engineers, installers, service technicians, and wholesalers better understand the products, applications, industry topics, and trends that will help you do your job better.

Create your Danfoss Learning account for free at [www.danfoss.com/en/service-and-support/learning](https://www.danfoss.com/en/service-and-support/learning).

### Get local information and support



Local Danfoss websites are the main sources for help and information about our company and products. Find product availability, get the latest regional news, or connect with a nearby expert—all in your own language.

Find your local Danfoss website here: [www.danfoss.com/en/choose-region](https://www.danfoss.com/en/choose-region).

### Coolselector®2 - find the best components for you HVAC/R system



Coolselector®2 makes it easy for engineers, consultants, and designers to find and order the best components for refrigeration and air conditioning systems. Run calculations based on your operating conditions and then choose the best setup for your system design.

Download Coolselector®2 for free at [coolselector.danfoss.com](https://coolselector.danfoss.com).