

# MASTERZONE™ ZONING SYSTEM – 4 Zones

Model MZS4

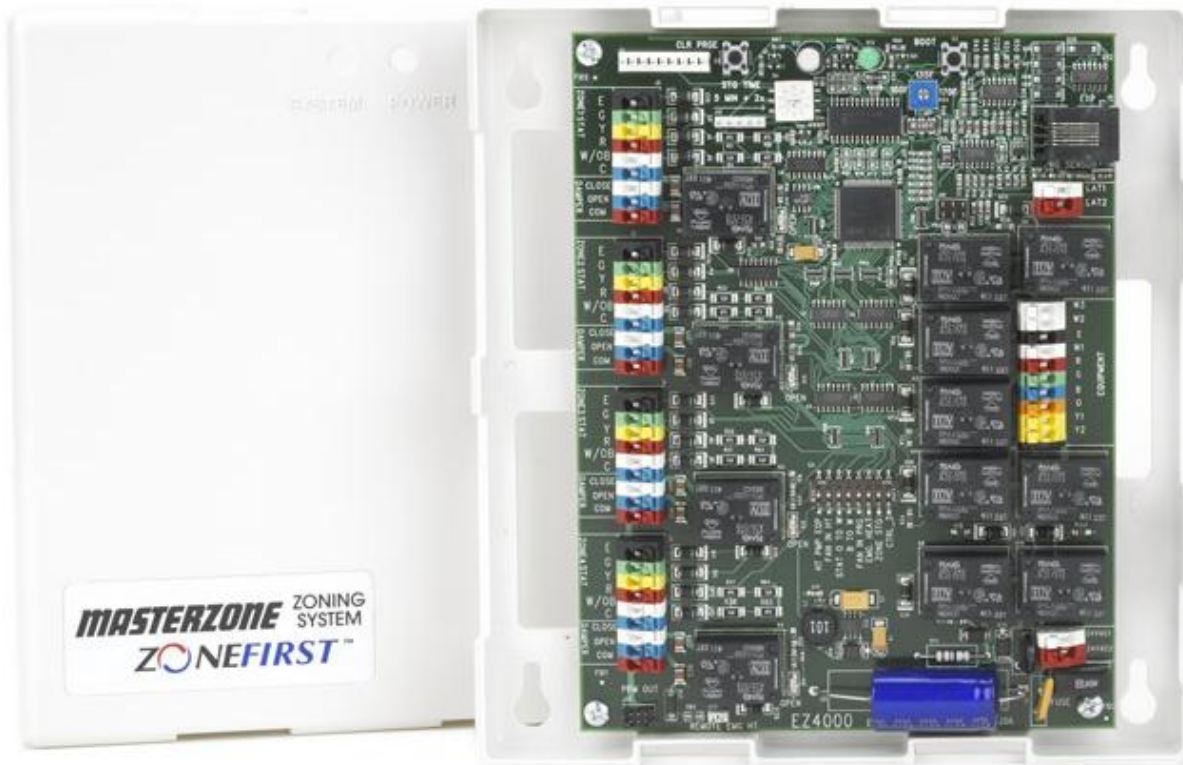

Installation and Operating Instructions

**ZONEFIRST®**  
Controlling Your Comfort Room By Room

# MASTERZONE™ ZONING SYSTEM

## FEATURES

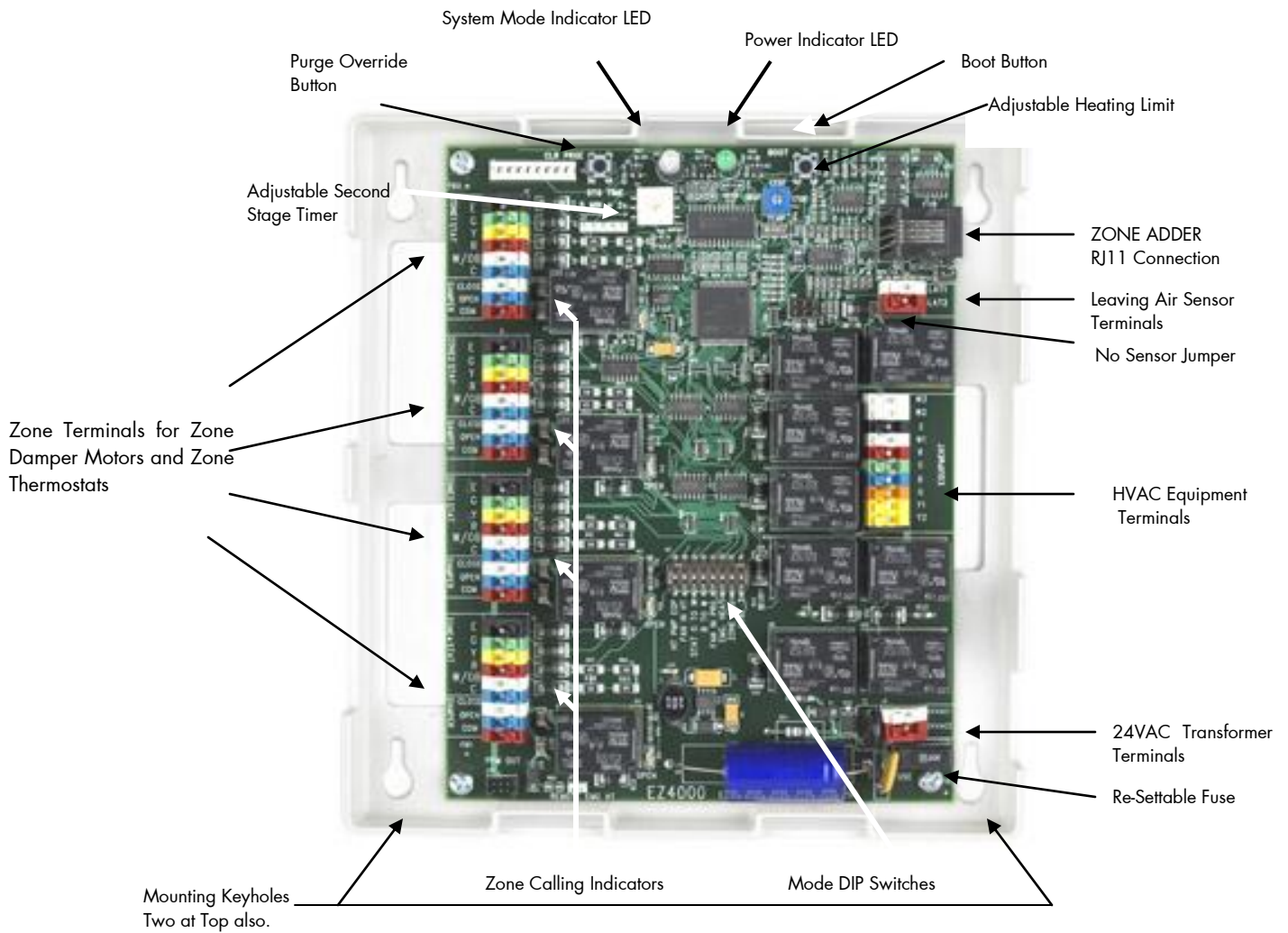

## INSTALLATION

The MasterZone™ Zoning System-4 is a four (4) zone control panel that controls up to four zones of heating and cooling. The MZS4 panel is the central control panel that all zone dampers, zone thermostats, HVAC Equipment, power transformer, Leaving Air Sensor and ZoneAdder™ panels are wired.

When installing the MZS4 panel it is important to pick a central location where it is most convenient to bring all the wires. Most often this is at the furnace or air handler. It is often the most convenient location and closest to power, the HVAC unit controls and the zone dampers when typically located at or near the plenum.

The MZS4 panel is made of sturdy ABS plastic and can be mounted to any flat surface. It is recommended that the panel be mounted to a wall or return plenum and NOT on the furnace or plenum where it will be in contact with the hot temperatures.. The panel can be located in an attic space or in an enclosed cabinet of a rooftop unit, in order for the panel to be in direct exposure to the elements.

The cover easily removes from the case by pulling firmly and separating the cover from the case exposing the circuit board. There are 4 key-hole mounting points in each corner of the case. The case has openings in the rear of the case as well as the side for all wiring. Wiring can come from the back as well as the side in order to make a neat installation.

## OPERATION

The MZS4 can control various types of HVAC Equipment all from the same panel. The MZS4 features allow the use of single stage thermostats to control up to three stage heating and two stage cooling and simple heat pump thermostats to control heat pumps. The MZS4 has various features that make installation and checkout very simple for all of the board's functionality.

The MZS4's basic function is zone control. On a call for heating or cooling, the panel will accept the first call from any zone. Upon accepting this call the MZS4 will open the damper(s) to the zone(s) calling, close the damper(s) to those zones not calling, activate the needed HVAC controls for heating or cooling, whichever is being called and not accept any calls for the opposite mode.

Any calls for the opposite mode will be locked out until the initial mode is either satisfied or a period of time has elapsed that is sufficient for the first mode to satisfy, a maximum of 20 minutes, when both calls occur simultaneously. An exclusive sequence determines the time the unit has been running or needs to continue to run in order to adequately provide conditioning for each mode. If a particular mode has already been calling for 20 minutes or longer and an opposite call comes in the MZS4 will immediately drop the mode, enter the purge mode in order to dissipate the conditioned air into the zones calling before switching over to provide the new conditioning call to its zones.

When using the MZS4 to control multi-stage heating and/or cooling, the extra stages are controlled based upon time after the first stage call from the thermostat. When any zone calls the panel's built-in timer begins and after the set period of time elapses the MZS4 will also activate the W2 for Heating or Y2 for Cooling. In heating, after the second stage is activated the same timer will control the third stage of heating. The Stage Timer is adjustable from 5 to 23 minutes after the first stage call. Once the extra stages are on, these stages will continue to run until the first stage is satisfied or the Leaving Air Sensor limit setting is reached. (See Leaving Air section for further information.)

Once all zone thermostats are satisfied for heating and cooling, the MZS4 will accept Fan calls allowing Continuous Air Circulation(CAC) in those zones where the thermostat's Fan Switch is set to ON. These zone dampers will be Open while the dampers to the zones where the Fan Switch is set to AUTO will be CLOSED.

When all zone thermostats are satisfied for both Heating and Cooling, and all Fan switches are set to AUTO position, the HVAC unit will be off and all zone dampers will return to a normally open position. Once a zone calls for heating, cooling or fan, the dampers to the calling zones remain open and the dampers to the zones not calling will close.

## Set-Up for Various HVAC Equipment

The MZS4 is factory set for conventional fossil fuel (oil or gas) single and up to three stage heating and two stage cooling. The panel only needs to be configured when using with an conventional electric furnace or hydro-air system in order to bring the fan on with a call for heat, or when using with a heat pump equipment and thermostats.

Most all of the panel configuration is done by setting the DIP switches in the lower center of the panel. Below is show their setting and functions.

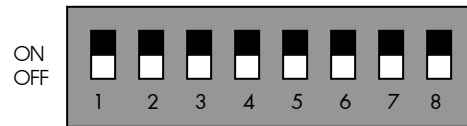

1. **HP EQP** – Heat Pump Equipment – This switch changes the output of the HVAC Equipment terminals from conventional Heating and Cooling to a traditional Heat Pump Output. When OFF, a heat call activates the W1 output and the second stage activates W2. When ON a Heat call activates the Y1 output to bring on the compressor for first stage and Y2 for the second stage, of both heating and cooling. W3 is activated on a third stage call in either mode.
2. **FAN HEAT** – Activates the G output to turn the Fan on with a call for Heat. This is used for Heat Pumps, Electric Heat furnaces and Hydro-Air Systems. In the OFF position the MZS4 will not activate the Fan in heating unless there is a fan call from one of the zone thermostats.
3. **O TO W** – Switch is placed to ON when using Heat Pump thermostats that use an O terminal to activate the reversing valve in COOLING. The O on the thermostat is wired to W on the zone terminal in order to determine if the call is for heating or cooling. All zone thermostats must operate and be wired the same way.
4. **B TO W** – Switch is used when using Heat Pump thermostats that use a B terminal to activate the reversing valve in HEATING. The B terminal on the thermostat is wired to W on the zone terminal in order to determine if the call is for heating or cooling. All zone thermostats must operate and be wired the same way. **NOTE: Some OEMs use the B terminal as a transformer Common and not as the heating reversing valve. These thermostats will use the O terminal for the reversing valve and should be wired accordingly using DIP Switch #3. The B terminal will then be wired to the C terminal on the thermostat terminal block.**
5. **FAN PRG** – This switch keeps the fan running during the purge time in order to dissipate the conditioned air into the last zone(s) calling. Placing this switch to ON, prevents the fan from turning off from the fan control in the HVAC Unit during the purge mode and coming back on moments later if another call is waiting. In OFF the fan will be control by HVAC Fan controls. This is desirable in residential to prevent cold drafts after heating by having the switch OFF.
6. **EMG HEAT** – EMERGENCY HEAT – This switch can be used to place all zones into the Emergency Heat mode. This switch would be used when single stage thermostats are used. **NOTE: There is no indication on the panel to show this switch is ON.**
7. **ZONE STG** – STAGE CONTROL – This switch is used to control how the second stage of heating and cooling is determined. In the OFF position, the second stage is controlled by the timer. In the ON position the second stage is brought based on the number of zones calling. Greater than 50% of the zones calling will bring on the second stage, for both heating and cooling.
8. **CTRL 3** – Future Use

One of the many features of the DIP switches is if at anytime the equipment is changed from single stage to heat pump or vice versa the thermostats do not need to be changed with the equipment change. Changing the DIP switch settings is all that is needed.

## Leaving Air Temperature Sensor

The Leaving Air Temperature Sensor, Model ZPS, is a remote sensor that is located in the supply air duct to sense the leaving air temperature of the HVAC Unit. The ZPS is a high limit protection for the heating and a low limit protection for the cooling. When zoning, the airflow through the HVAC Unit is critical. The ZPS protects the equipment in low air flow situations as well as when by-pass air is being directed back into the return air duct.

The heating limit is adjustable from 100°F to 170°F. The cooling limit is fixed at 40°F. When the ZPS senses heating above its set point, or cooling below its set point, the MZS4 will drop both stages of heating or cooling. The ZPS must sense a 10°F fall for heating or rise for cooling before re-activating the first stages of heating or cooling. If two stage heating or cooling is being used the second stage timer will start again once the first stage is re-activated.

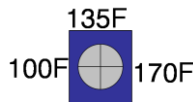

The ZPS requires 2 wires from the sensor to the LAT1 and LAT2 terminals on the MZS4 panel. The ZPS probe can also be adjusted for length by loosening the end nut and sliding the probe thru the mounting plate in order for the probe to pass through any duct insulation

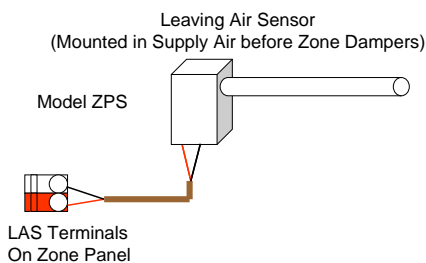

**NOTE: If the ZPS is not used, the NO SENSOR jumper located near the LAT terminals must be placed across the two pins. When the sensor is used the jumper must be removed from the pins.**

## Stage Timer

The MZS4 has a built-in stage timer that eliminates the need and added cost of using two stage thermostats. On a call for either heating or cooling the timer begins. A minimum of 5 minutes, adjustable to a maximum of 23 minutes, can be set in order to activate the W2, W3 and Y2 outputs after the first stage call.

The Stage Timer is marked 0 through 9 and each increment is indented as the dial is rotated. A minimum 5 minutes is set when the dial is set to 0. To calculate the stage timing the dial setting is multiplied by 2 and added to the base of 5 minutes. Example: Dial setting is  $3 \times 2 = 6 + 5 = 11$  Minutes for the Stage Timer.

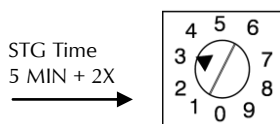

When any zone calls the timer starts and activates the second stage W2 or Y2 after the set time elapses. The timer also controls W3 after the same time elapses after the W2 call.

## PURGE TIME

The MZS4 has a built-in Purge Time after each call is satisfied and provides a minimum off time before another call is initiated. The Purge Time is set at 2.5 minutes after all calls for a particular mode are satisfied or when the Changeover Timer requires a changeover due to opposing calls.

After all calls are satisfied or the changeover timer activates, the Purge Timer begins and the heating or cooling, whichever was on, is deactivated. Typically the fan may be running during this time and the damper(s) to the last zone(s) calling will remain open to purge the conditioned air only into those zones that were calling for the conditioning.

DIP Switch 5 can be set ON to keep the Fan running during the Purge mode in order to prevent the fan cycling off and back on between modes. In the instance where the Fan staying may create a draft, and the frequency of opposite calls is minimal this switch can be kept to OFF.

The CLR PRGE button on the top left of the panel can be pushed to override the Purge mode and speed installation and checkout. This button is only active when the System LED is AMBER.



## Minimum On Timer

The MZS4 also has a minimum on time whenever the compressor operates in order to prevent frequent short cycling. Once there is a call for cooling or the compressor on a heat pump, the MZS4 will hold that call for a period of 2 minutes.

## CHANGEOVER TIMER

Whenever a call is made for either heating or cooling, the changeover timer is activated in order to track the amount of time heating or cooling is on. When an opposite call is made after a first call is existing the changeover timer calculates the amount of time the unit has already been supplying the first mode in order to determine how long it will hold off the opposite call. If an opposite call is made shortly after the first call, the opposite call may be held off for as much as 20 minutes. If the first call or subsequent calls for the first call mode has had that mode operating for up to 20 minutes already and an opposite call comes in after 20 minutes, the changeover timer will immediately recognize the opposite call, shutting off the current mode, enter the purge mode and automatically switch to the opposite mode.

The longer a call has been running up to 20 minutes, the shorter the wait time will be for an opposite call. If a call is over 20 minutes and an opposite call is made the changeover will be immediate following the purge time. This intelligent changeover timing makes the MZS4 unique to any other zoning system.

## Zone-Adder™ Control

The MZS4 Zone Panel can be added onto with the MasterZone-Adder™ Model MZA. The MZA is available as a 2 zone adder panel and expands any MZS4 panel up to 10 zones, using a maximum of three (3) MZA panels. The MZA2 panel is connected by a 6 conductor RJ11 telephone cable. This makes wiring between the MZS4 and MZA2 literally a snap. This cable is included with each MZA panel.

## CHECKOUT

The MZS4 has unique features that simplify the checkout of the system and has LED readouts that constantly indicate the system operation. Once 24 Volt Power is applied to the panel the Green Power LED will illuminate. This will stay illuminated constantly when power is applied.

The System LED will provide several different indications based upon color and if it is flashing.

- Heat ON - RED
- Heat Limit - RED Flashing
- Cool ON - GREEN
- Cool Limit - GREEN Flashing
- FAN ON/PURGE - AMBER
- TIME DELAY - AMBER Flashing

Each zone has its own small Green indicator LED next to each zone relay. This light is lit when the specific zoning is calling for the mode shown on the System LED.

**WIRING**

The MZS4 is very simple to wire and requires only a minimum number of connections. The MZS4 terminal blocks are screw-less and all wires can easily be pushed into their respective terminal by de-pressing the button for each point and releasing once the wire is seated. To remove the wire, just press its button again and remove the wire.

**WIRING DIAGRAM 1 – Single Stage Thermostat**

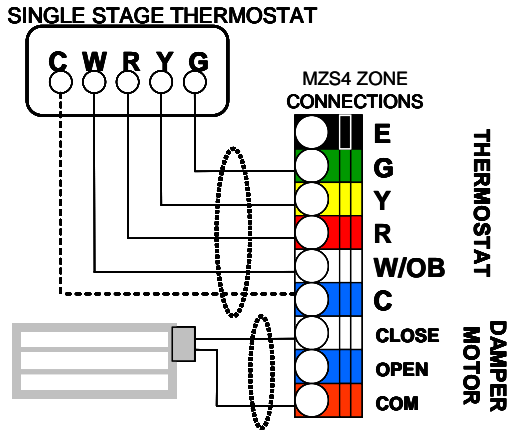

**WIRING DIAGRAM 2 – Single Stage, Two Stage and Three Stage Heating Equipment and up to Two Stage Cooling**

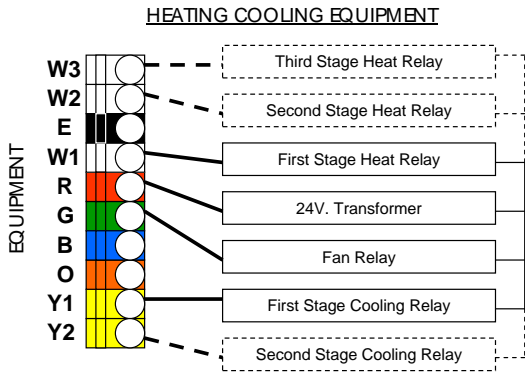

**WIRING DIAGRAM 3 – Heat Pump Thermostats**

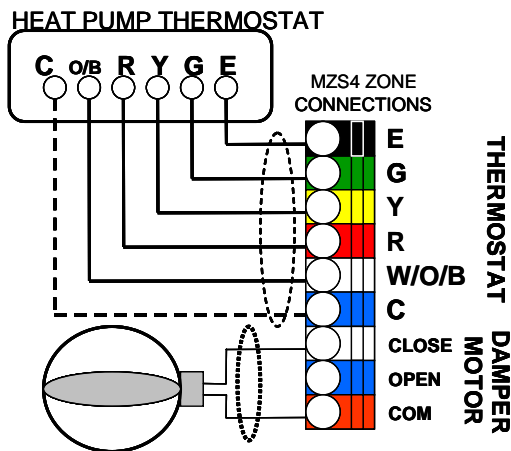

**WIRING DIAGRAM 4 – Typical Heat Pump Equipment**

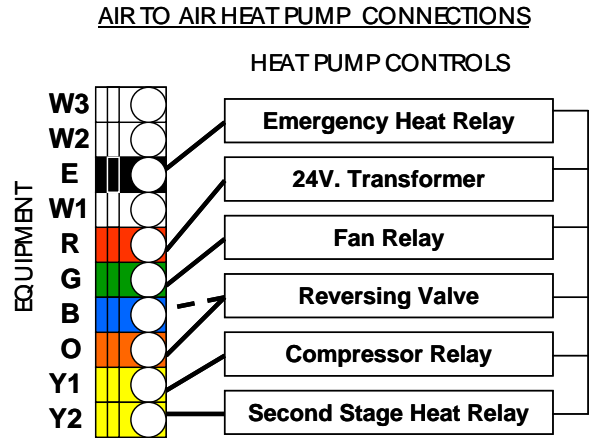

**TROUBLESHOOTING**

The MZS4 is a very simple control to troubleshoot, especially with the LED indicators. The only other device needed is a simple Volt/Ohm meter. Almost all problems can be traced to an external component or wiring to the MZS4. While the MZS4 has been designed to operate under extreme voltage conditions and is fuse protected, like any computer the micro-processor can hang up and not operate properly. For these instances a BOOT button has been installed that re-boots the micro-processor just like your computer. Pressing this button for a few seconds and then release it will allow the micro-processor to re-boot and in most all cases eliminate the problem. If not the following procedure can help isolate the problem.

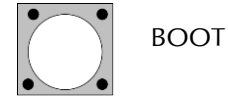

**Zone(s) Not Calling**

Each zone has a Green LED next to the zone relay when it is calling and that calling is being recognized by the MZS4. If a zone is supposed to be calling and the Zone LED is not on, check for 24VAC across the thermostat terminal C and the Y, if a Cool call, W if a Heat Call, or G if a Fan call. If there is no voltage here at the panel the panel is not getting the signal from the thermostat. The problem is mis-wiring, a broken wire or a problem in the thermostat. To check the zone on the panel, place jumper from R to Y, R to W or R to G to see that the panel is operating properly.

**Zone(s) Will Not Shut Off**

If a zone will not stop calling, the Zone LED should still be on. Depending on the call disconnect the Y, W or G wire from the terminal strip. The zone will drop out. Check the thermostat wiring for a mis-wiring or short that keeps the zone calling.

**Damper Motor Checkout**

Each zone has Green indicator light located to the right of the zone damper's relay. When all zones are satisfied all zone lights are lit Green indicating all zone dampers will be Open. To check this there will be 24VAC across the COM and Open terminal. When any zone calls, the damper(s) to the satisfied zone(s) will power close and the indicator light will go out. When the damper is to be closed there will be 24VAC across COM and CLOSE.



55 Bushes Lane • Elmwood Park, New Jersey 07407-3204 USA  
 Telephone 1.877.604.1044(US and Canada) FAX 1.201.794.1359  
 www.zonefirst.com info@zonefirst.com

# MZS4 WIRING DIAGRAM



www.zonefirst.com

