

**DMA**  
**Motor Actuator**  
**Installation Instructions**

**DMK/6**  
**Butterfly Control Valve**  
**Installation Instructions**

**DMA ACTUATOR SPECIFICATIONS**

The **DMA** actuator drives from 0 to 90 degrees via 4-20 mA input signal. It can move in any direction and stop anywhere over the entire 90 degree stroke.

**Electrical Rating**

110-120 Vac (+10 / -15%) 50-60 Hz

**Max. Power Rating**

2.0 VA Holding, 5.4 VA Operating

**Max. Torque Ratings**

Timing	Holding	Operating
6	12.4 in-lb	5.3 in-lb
12	24.8 in-lb	8.9 in-lb
30	26.5 in-lb	17.7 in-lb

**Position Resolution**

0.08mA resolution; minimum of 0.45° per step

**Max. Contact Rating for Auxiliary Switch**

1.5 Amps at 120 Vac 50/60 Hz

**Enclosure Rating**

NEMA Type 1 enclosure (standard with DMA)

NEMA Type 4 enclosure available (P/N 240 456)

**Input Control**

4 to 20 mA

**Position Feedback or Slave Output**

4 to 20 mA; 500 ohm maximum impedance.

Resistance across terminals 8 & 10 is 250 Ohms.

**Ambient Temperature Rating**

+15 °F to +120 °F (-10 °C to 50 °C)

**Approvals**

UL Recognized Component: File No. E142163

CSA Certified: File No. 157406-1378915

Commonwealth of Massachusetts Approved Product

Approval code G1-1107-35



**DMK BUTTERFLY VALVE SPECIFICATIONS**

The **DMK/6** butterfly control valve actuates from 0 to 90 degrees in either direction; it is not a tight shut-off valve. Input-side male thread and output-side female thread enable assembly directly to DUNGS shutoff valves.

**Gases**

Dry, natural gas, propane, butane; other noncorrosive gases. Suitable for up to 0.1% by volume, dry H<sub>2</sub>S. A "dry" gas has a dew point lower than +15 °F and its relative humidity is less than 60 %.

**Max. Pressure**

7 PSI (500mbar) MH194167

**Max. Differential Pressure for Optimal Performance**

1.5 PSI (100mbar)

**Max. Body Pressure**

15 PSI (1000mbar)

**Mounting Position**

Multipoised

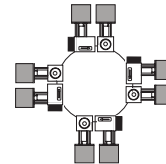

**Ambient Temperature for DMK**

+5° F to +140° F (-15° C to 60° C)

**Actuator angle**

90 degrees from open to closed

**Approvals**

UL Listed Component: File No. MH18741

Commonwealth of Massachusetts Approved Product

Approval code G1-1107-35



**ATTENTION**

- Read these instructions carefully.
- Failure to follow them and/or improper installation may cause explosion, property damage and injuries.
- Installation must be done with the supervision of a licensed burner technician.
- Check the ratings in the specifications to make sure that they are suitable for your application.
- Never perform work if gas pressure or power is applied, or in the presence of an open flame.
- Once installed, perform a complete checkout including leak testing.
- Verify proper operation after servicing.
- The system must be installed, used, and maintained to meet all applicable national and local code requirements such as but not limited to NFPA 86, CSD-1, ANSI Z21.13, UL 795, NFPA 85, or CSA B149.3.

Karl Dungs, Inc

3890 Pheasant Ridge Dr. NE, Suite 150, Blaine, MN 55449 U.S.A.

Phone: (763) 582-1700 Fax: (763) 582-1799 E-mail: info@karldungsusa.com

## WIRING

### Wiring the DMA

1. Remove all power supplies.
2. Use minimum AWG #16 class 1 wiring for all terminals.
3. Remove cover to access the terminal block.
4. Only use the specified terminals. Terminal 8 must be the + input and terminal 10 must be the - input.
5. The cover has an intergrated protective barrier that physically separates the wiring from the moving adjustment switches and cams. Wiring must be properly routed so that the cover can be installed.
6. For terminals 8 and 10, use properly sheilded wires, that are grounded on both sides, and run through conduit containing only low voltage (24V) wiring.

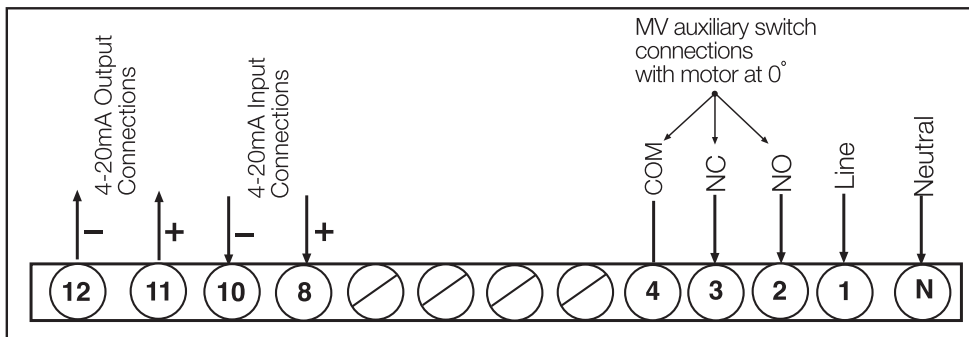

Terminal Block for DMA

## MOUNTING

### Mounting DMA to a DMK/6 butterfly valve

1. Remove the clear cover from the DMA
2. Insert the shaft from the DMA into the linkage of the DMK/6 until the motor is flush on the DMK/6 mounting plate. snug the set screw with a 2.5 mm allen wrench. Torque to 15 lb-in.
3. Insert the M5 X 55 mounting bolts (supplied) through the DMA motor mounting holes. Take care not to break the plastic covers off of the bolt holes. Hand tighten the 8mm hex nuts that are supplied. Torque the bolts to 45 lb-in.

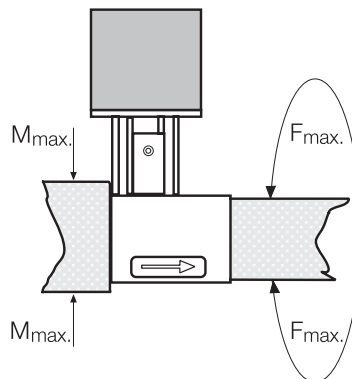

### Mounting the DMK/6 to a shutoff valve

1. Turn off the gas supply.
2. Refer to the flow direction on the valve housing.
3. **Note:** Aluminum to Aluminum connection: Coat inner and outer threads with a suitable lubricant before sealing the inner and outer threads.
4. **DO NOT** use any part of the DMA or the mounting bracket of the DMK/6 assembly as a lever to tighten! Use appropriate sized wrench.
5. Tighten connections. Use the chart below for torque specifications.
6. Perform a complete leak test after installation.

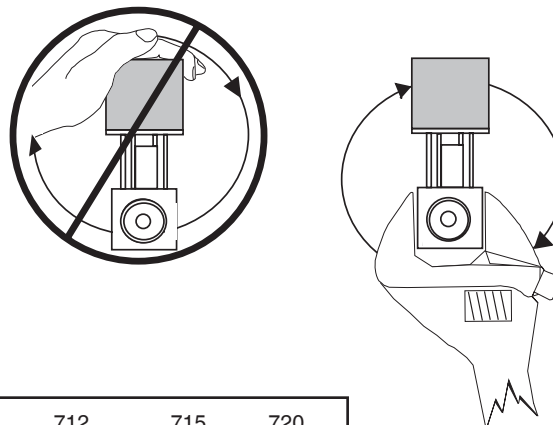

<b>DMK</b>	707	710	712	715	720
<b>Max. lb-in</b>	560	750	875	940	1190

## DMA ACTUATOR CALIBRATION AND ADJUSTMENTS

### Calibrating the DMA

Note: The red and yellow switches are factory set outside of the 0 to 90° operating range. Do not change these adjustment dials until calibration is complete. **DO NOT** use these switches in lieu of the calibration.

#### To Adjust Minimum Position

1. Apply a 4 mA DC input signal.
2. Turn the **Y min** (Zero) potentiometer (adjusting range 0 to 100 % of stroke) to position the actuator at the desired minimum position. Turning **Y min** (Zero) CCW drives the minimum position towards 0°.

#### To Adjust Maximum Position

1. Apply 20 mA DC input signal.
2. Turn the **Y max** (Span) potentiometer (adjusting range 25 to 100 % of stroke) to position the actuator at the desired maximum position. Turning **Y max** (Span) CCW drives the setpoint towards 0°.

**Note: Y min** (Zero) must be no more than 75 % of **Y max** (Span) (reference: 90° = 100%). E.g. if the maximum position is set at 85°, the minimum position can be set at 64° maximum. ( $85^\circ * 0.75 = 64^\circ$ ).

### Switch Adjustment:

Note: Use the scale under the Red ST1 switch to field set the switches. The DMA incorporates two limit switches that limit the crank shaft from exceeding a set point if the zero or span potentiometer fails. The DMA also has an SPDT auxiliary switch. All switches can be adjusted anywhere over the 90° stroke.

**ST1 Limit Switch (Red):** This switch limits the minimum position at 0° or more. Set the switch at approx. 1° LESS than the Y Min. setpoint. The small set screw on the side of the red dial can be used for fine tuning adjustment.

**ST2 Limit Switch (Yellow):** This switch limits the maximum position at 90° or less. Set the switch at approx. 1° MORE than the Y Max. setpoint. The small set screw on the side of the yellow dial can be used for fine tuning adjustment.

**MV Auxiliary-Switch (Yellow):** Set the switch to trip at the desired setpoint using the scale under the Red ST1 switch. When the motor is at 0°, the NC contact 4 and 3 opens, and the NO contact 4 and 2 closes.

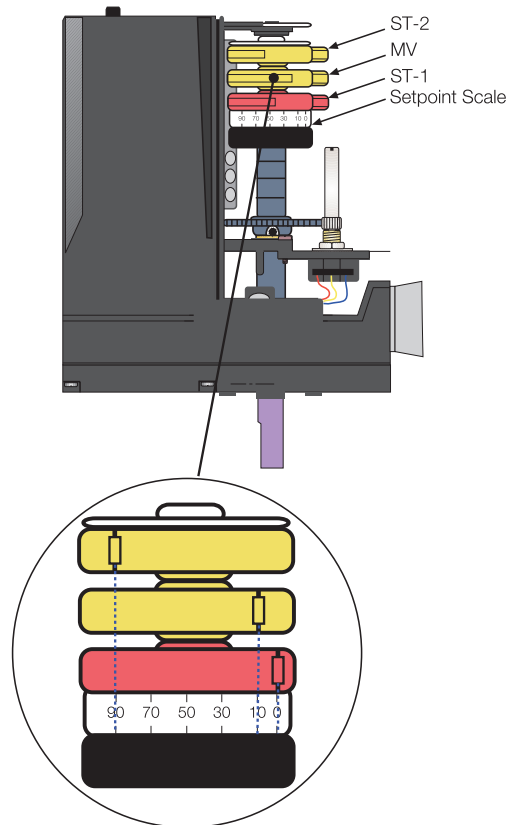

## ACCESSORIES

### Description

### Order No.

NEMA 4 metal enclosure

240-456