

POWER-fin®

SMART SYSTEM™

OPERATING CONTROL FEATURING
A BUILT-IN CASCADING SEQUENCER

UP TO 87% THERMAL EFFICIENCY

500,000 TO 2,000,000 BTU/HR

MODELS AVAILABLE IN 100% ON/OFF,
2:1 TURNDOWN OR 5:1 TURNDOWN

LESS THAN 10 ppm NOx

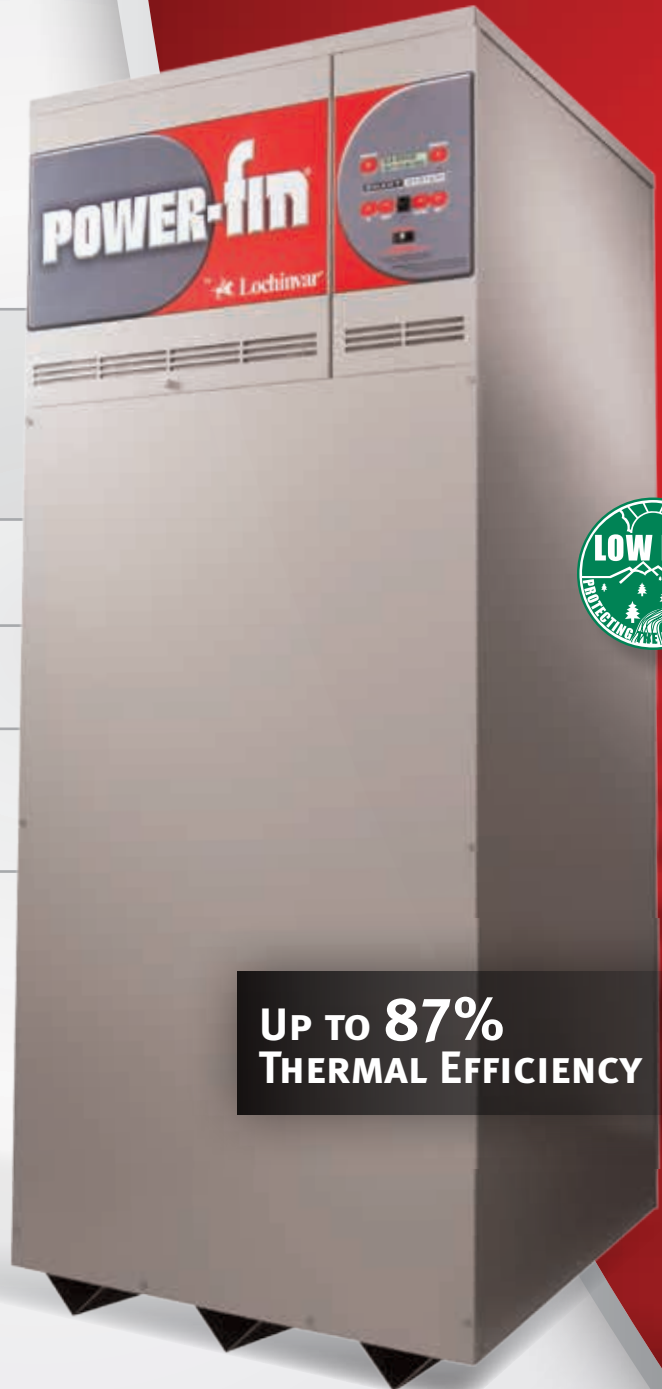

UP TO 87%
THERMAL EFFICIENCY

POWER-FIN®

A SYMBOL OF LOCHINVAR'S COMMITMENT TO EXCELLENCE!

In 1986, Power-Fin® redefined the water heating industry with space-saving design, groundbreaking efficiency and venting flexibility. Twenty years later, we're again raising the standard for innovation, reliability and LEED-conscious design.

The latest generation of Power-Fin offers expanded burner modulation and the advanced SMART SYSTEM™ operating control, including a built-in cascading sequencer for up to eight boilers.

In today's market, sophisticated, versatile control systems and equipment that meets "green building" criteria are increasingly in demand. Power-Fin boilers continue to evolve, with new "Built-in Advantages" from Lochinvar.



First Power-Fin in 1986

INFINITE MODULATION

With thermal efficiencies up to 87%, Power-Fin boilers feature infinitely modulating burner firing rates (turndown), precisely matching the firing rate to heating load requirements. The result is better overall efficiency and less cycling.

Power-Fin boilers may be specified as either 5:1 turndown (502 - 2001), 2:1 turndown (1501 - 2001), or 100% ON/OFF (502 - 1302). With 5:1 turndown the burner fires as low as 20% of maximum input when demand is lowest and increases the firing rate up to 100% as demand increases. Models with 2:1 turndown modulate from 50% to 100% of maximum input.

GASKETLESS HEAT EXCHANGER

The Power-Fin heat exchanger features an array of 20 or 24 copper-finned tubes surrounding the burner for maximum heat transfer. Lochinvar also pioneered the "gasketless" heat exchanger, which eliminates the use of O-rings and gaskets. Because of the time-proven reliability of this design, the Power-Fin heat exchanger is backed by a 10-year limited warranty.

The vertical heat exchanger also makes Power-Fin compact and easy to handle, install and service. All access for installation or service is through the front or back, and multiple units can line up side-by-side with zero clearance to combustibles.

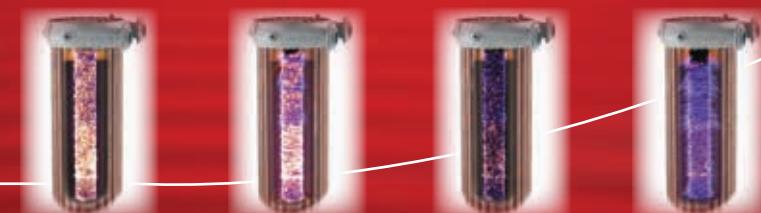

23-1/4" (502 - 1302)
27-1/4" (1501 - 2001)

zero clearance
to combustibles

SMART SYSTEM™

CONTROL FEATURES

BUILT-IN CASCADING SEQUENCER CONTROLS UP TO 8 UNITS

CASCADE COMPATIBILITY WITH CREST CONDENSING BOILER TO CREATE A FRONT END LOADING SYSTEM

2-LINE 16-CHARACTER LCD READOUT OF SETUP, SYSTEM STATUS AND DIAGNOSTIC DATA IN WORDS, NOT CODES

3-PUMP CONTROL FOR OPERATION OF BOILER PUMP, SYSTEM PUMP, DOMESTIC HOT WATER PRIORITIZATION PUMP

LOW-VOLTAGE TERMINAL STRIP WITH 28 POINTS OF CONNECTION

OUTDOOR RESET ADJUSTS SETPOINT BASED ON A RESET CURVE

COMPATIBILITY WITH HOT WATER GENERATORS – ONE BOILER IN THE SYSTEM CAN BE ASSIGNED FOR DOMESTIC HOT WATER PRIORITIZATION (DHWP) TO MEET DOMESTIC WATER DEMAND

0-10 Vdc BMS INPUT FOR EASY INTEGRATION INTO BUILDING MANAGEMENT SYSTEMS

OPTIONAL SMART SYSTEM PC SOFTWARE FOR ADVANCED SETUP AND DIAGNOSTICS

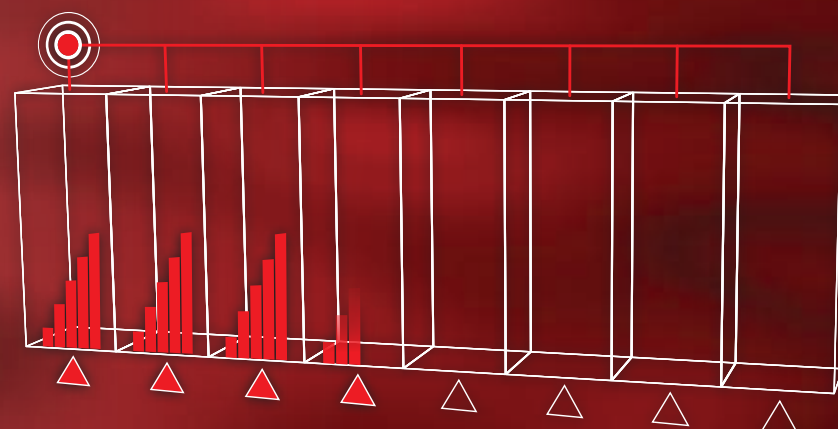

LEAD-LAG ROTATION

Every 24 hours, the SMART SYSTEM automatically shifts the "first on" boiler role to the next unit in the sequence. This rotation ensures long life by distributing "lead-lag" run times equally over each unit in the system.

VENTING SOLUTIONS

Power-Fin features flexible two-pipe, independent air inlet and exhaust vent piping. When equipped with 100% ON/OFF (F Models) Firing Controls (502 - 1302), 2:1 (B Models) Modulating Firing Controls (1501 - 2001), the Power-Fin utilizes Category I, Type B vent material and is ideal for replacement/retrofit applications with an existing vent stack. When equipped with 5:1 (M Models) Modulating Firing Controls, (502 - 2001) the Power-Fin requires Category IV, corrosion-resistant, sealed vent pipe. Category IV models provide more venting flexibility and expanded turndown. In addition, (M Models) Modulating units may be installed as Category II appliances, allowing multiple units to be manifolded together into a common vent stack – giving you even more design options!

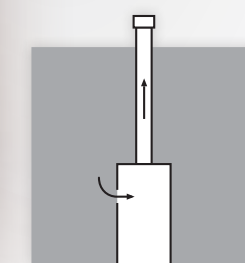

VERTICAL VENTING

Using Category I or Category IV vent materials

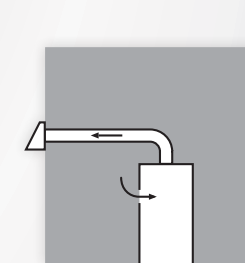

SIDEWALL VENTING*

Horizontal venting up to 50 equivalent feet using Category IV vent materials. This option only available with 5:1 (M) firing code models.

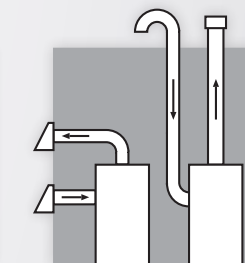

DIRECT VENTING*

Horizontal or vertical venting up to 50 equivalent feet. Draws combustion air from the same pressure zone using Category IV vent materials. This option only available with 5:1 (M) firing code models.

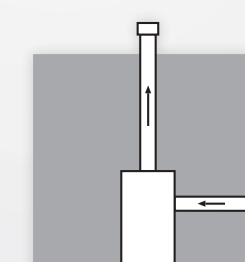

DIRECTAIR VERTICAL*

Vertical venting up to 50 equivalent feet. Draws combustion air up to 50 ft. from a different pressure zone using Category I or IV vent materials.

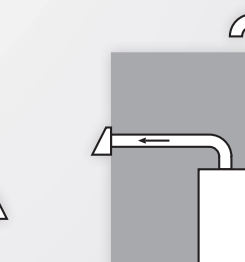

DIRECTAIR HORIZONTAL*

Vents horizontally up to 50 equivalent feet. Draws combustion air up to 50 ft. from a different pressure zone using Category IV vent materials. This option only available with 5:1 (M) firing code models.

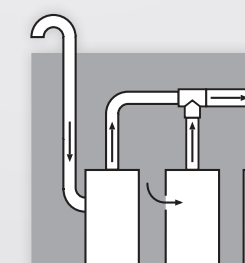

COMMON VENTING*

Vents multiple units horizontally through one vent termination and draws combustion air from the room, roof or sidewall. Category IV to II conversion kit required with (M) firing code models.

*Requires factory-supplied vent kit with M firing code models. See Specification Chart for specific venting sizes based on venting materials category type.

POWER-fin®

Lochinvar
SMART SYSTEM™

FEATURING THE FIRST BUILT-IN CASCADING SEQUENCER!

A SYMBOL OF LOCHINVAR'S COMMITMENT TO EXCELLENCE!

In 1986, Power-Fin® redefined the water heating industry with space-saving design, groundbreaking efficiency and venting flexibility. Twenty years later, we're again raising the standard for innovation, reliability and LEED-conscious design.

The latest generation of Power-Fin offers expanded burner modulation and the advanced SMART SYSTEM™ operating control, including a built-in cascading sequencer for up to eight boilers.

In today's market, sophisticated, versatile control systems and equipment that meets "green building" criteria are increasingly in demand. Power-Fin boilers continue to evolve, with new "Built-in Advantages" from Lochinvar.



First Power-Fin in 1986

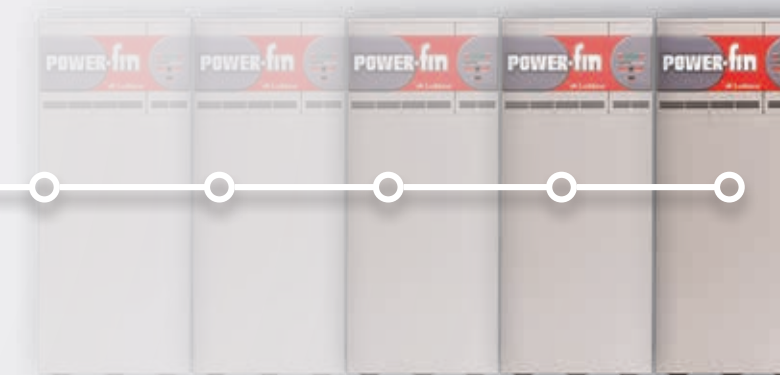

Power-Fin® is the first modulating boiler with a built-in cascading sequencer for up to 8 units. This integral component of the new SMART SYSTEM™ control eliminates the initial cost and labor required with installation of a separate sequencer. And because it's engineered specifically for Power-Fin, it removes any uncertainty about using a "third-party" sequencer, to ensure precise, dependable cascading operation.

When utilizing the built-in cascading sequencer, Power-Fin Boilers communicate through a simple 2-wire daisy chain connection. On demand, one boiler in the system functions as the lead unit and modulates with demand to capacity. The additional load then "cascades" to the second boiler, which fires and modulates to meet added demand.

Cascading continues as additional boilers fire in sequence, until all units are in operation or demand is satisfied. When demand drops, the cascading process reverses, with the precision control and performance you expect from Lochinvar.

INFINITE MODULATION

With thermal efficiencies up to 87%, Power-Fin boilers feature infinitely modulating burner firing rates (turndown), precisely matching the firing rate to heating load requirements. The result is better overall efficiency and less cycling.

Power-Fin boilers may be specified as either 5:1 turndown (502 - 2001), 2:1 turndown (1501 - 2001), or 100% ON/OFF (502 - 1302). With 5:1 turndown the burner fires as low as 20% of maximum input when demand is lowest and increases the firing rate up to 100% as demand increases. Models with 2:1 turndown modulate from 50% to 100% of maximum input.

GASKETLESS HEAT EXCHANGER

The Power-Fin heat exchanger features an array of 20 or 24 copper-finned tubes surrounding the burner for maximum heat transfer. Lochinvar also pioneered the "gasketless" heat exchanger, which eliminates the use of O-rings and gaskets. Because of the time-proven reliability of this design, the Power-Fin heat exchanger is backed by a 10-year limited warranty.

The vertical heat exchanger also makes Power-Fin compact and easy to handle, install and service. All access for installation or service is through the front or back, and multiple units can line up side-by-side with zero clearance to combustibles.

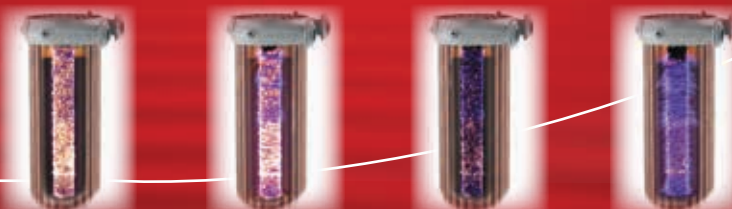

23-1/4" (502 - 1302)
27-1/4" (1501 - 2001)

zero clearance
to combustibles

POWER-FIN® BOILER DIMENSIONS AND SPECIFICATIONS

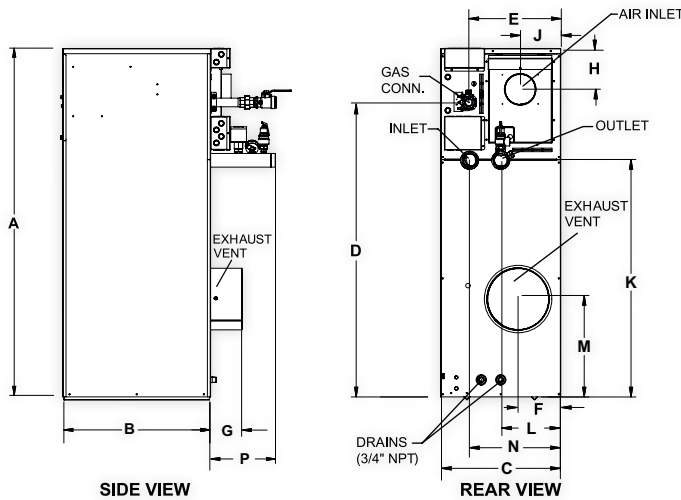

Model Number Guide			
PB	N	1501	M9
Model	Natural Gas	Btu/hr Input	Firing Controls

Power-Fin Boiler,
Natural Gas,
1,500,000 Btu/hr input,
M9 firing controls

POWER-FIN BOILER								DIMENSIONS AND SPECIFICATIONS							
Model Number	Input MBH	(B)/(F) Thermal Efficiency	Output MBH	Net AHRI Rating MBH	(M) Thermal Efficiency	Output MBH	Net AHRI Rating MBH	A	B	C	D	(B)/(F) E	(M) E	F	G
PBN0502	500	85.0%	425	370	85.0%	425	370	44-1/2"	28-1/2"	23-1/4"	34"	17-3/4"	19-1/2"	6-1/2"	6"
PBN0752	750	85.0%	638	554	85.0%	638	554	52"	28-1/2"	23-1/4"	41-1/2"	17-3/4"	19-1/2"	6-3/4"	6"
PBN1002	999	85.0%	850	739	85.0%	850	739	59-1/4"	28-1/2"	23-1/4"	48-3/4"	17-3/4"	19-1/2"	7-1/4"	6"
PBN1302	1,300	85.0%	1,105	961	85.0%	1,105	961	67-3/4"	28-1/2"	23-1/4"	57-1/4"	17-3/4"	19-1/2"	8-1/4"	6"
PBN1501	1,500	84.0%	1,260	1,096	85.0%	1,275	1,109	65-1/2"	29-3/4"	27-1/4"	58-3/4"	21"	21"	13-1/2"	8"
PBN1701	1,700	84.0%	1,428	1,242	85.0%	1,445	1,257	70"	29-3/4"	27-1/4"	63-1/4"	21"	21"	13-1/2"	8"
PBN2001	2,000	84.0%	1,680	1,461	85.0%	1,700	1,478	76-3/4"	29-3/4"	27-1/4"	70"	21"	21"	13-1/2"	8"

Model Number	H	J	K	L	M	N	(B)/(F) P	(M) P	Gas Conn.	Air Inlet	(B)/(F) Cat I	(M)* Cat II	(M) Cat IV	Shipping Wt. (lbs)
PBN0502	8"	7-3/4"	23"	11-1/2"	11-1/4"	17-1/2"	15-1/4"	15-1/4"	1"	5"	7"	7"	4"	505
PBN0752	8"	7-3/4"	30-1/2"	11-1/2"	11-1/4"	17-1/2"	15-1/4"	15-1/4"	1-1/4"	5"	9"	9"	5"	554
PBN1002	8"	7-3/4"	37-3/4"	11-1/2"	11-1/4"	17-1/2"	15-1/4"	15-1/4"	1-1/4"	6"	10"	10"	6"	603
PBN1302	8"	7-3/4"	46-1/4"	11-1/2"	19-1/2"	17-1/2"	15-1/4"	15-1/4"	1-1/4"	6"	12"	12"	8"	652
PBN1501	10"	9-1/2"	43-1/2"	5-3/4"	22-1/4"	21-1/2"	24-1/2"	19-1/2"	1-1/2"	6"	12"	8"	6"	1,065
PBN1701	10"	9-1/2"	48"	5-3/4"	25"	21-1/2"	24-1/2"	19-1/2"	1-1/2"	7"	14"	9"	7"	1,100
PBN2001	10"	9-1/2"	54-3/4"	5-3/4"	27-1/2"	21-1/2"	24-1/2"	19-1/2"	1-1/2"	8"	14"	10"	8"	1,127

Notes: Change 'N' to 'L' for LP Gas Model. No deration on LP models. All water connections are 2-1/2" *w/CAT II conversion kit

STANDARD FEATURES

- Up to 87% Thermal Efficiency (M)
- Up to 85% Thermal Efficiency (B/F)
- Modulating Burner with 5:1 Turndown
 - Hot Surface Ignition
 - Low NOx Operation
 - Sealed Combustion
 - Low Gas Pressure Operation
- Vertical & Horizontal Venting
 - Venting up to 50 Feet
 - Category I or Category IV Venting
 - Cat IV converts to Cat II w/ optional vent kit
- ASME Copper-Finned Tube Heat Exchanger
 - ASME Certified, "H" Stamped
 - Gasketless design
 - 160 psi working pressure
- On/Off Switch
- Adjustable High Limit w/ Manual Reset
- Flow Switch
- Low Air Pressure Switch
- Downstream Test Cocks
- 50 psi ASME Relief Valve
- Combustion Air Filtration
- Temperature & Pressure Gauge
- Zero Clearances to Combustible Material
- 1 Year Warranty on Parts
- 10 Year Limited Warranty (See Warranties for Details)

SMART SYSTEM FEATURES

- SMART SYSTEM Operating Control
 - 2 line, 16 Character Display
 - Dual Level Password Security
 - Domestic Hot Water Prioritization
 - Built in Cascading Sequencer for up to 8 Boilers
 - Building Management System Integration with 0-10 VDC Input
 - Outdoor Reset Control with Outdoor Air Sensor
 - Low Water Flow Safety Control & Indication
 - Inlet & Outlet Temperature Readout
 - Freeze Protection
 - Service Reminder
 - Time Clock
- Data Logging
 - Hours Running, Space Heating
 - Hours Running, Domestic Hot Water
 - Ignition Attempts
 - Last 10 Lockouts
- Programmable System Efficiency Optimizers
 - Night Setback
 - Anti-Cycling
 - Outdoor Air Reset Curve
 - Ramp Delay
 - Boost Temperature & Time

Three Pump Control

- System Pump Boiler Pump
- Domestic Hot Water Pump
- High Voltage Terminal Strip
 - 120 VAC / 60 Hertz / 1 Phase Power Supply
 - Three sets of Pump Contacts with Pump Relays

Low Voltage Terminal Strip

- 24 VAC Auxiliary Device Relay
- Auxiliary Proving Switch Contacts
- Flow Switch Contacts
- Alarm on Any Failure Contacts
- Runtime Contacts
- DHW Thermostat Contacts
- Room Thermostat Contacts
- System Sensor Contacts
- DHW Tank Sensor Contacts
- Outdoor Air Sensor Contacts
- Cascade Contacts
- 0-10 VDC BMS External Control Contact

Registered under U.S. Patent #7,506,617

FIRING CONTROL SYSTEMS

- M Indicates 5:1 Turndown, Category IV
 - B Indicates 2:1 Turndown, Category I
 - F Indicates 100% On/Off Fire, Category I
- M9 Standard
B9 or F9 Special Order, Factory Trimmed
M7, B7 or F7 California Code
M13, B13 or F13 CSD1/FM/GE Gap

OPTIONAL EQUIPMENT

- Alarm Bell
- MODBUS Communication
- BMS Gateway to LON or BacNet
- Cupro-Nickel Heat Exchanger
- High & Low Gas Pressure Switches w/ Manual Reset
- Low Water Cutoff w/ Manual Reset & Test
- SMART SYSTEM PC Software
- Vent Kits:
 - Horizontal Exhaust Cap
 - Horizontal Air Intake Cap
 - Horizontal Direct Vent Kit
 - Category IV to Category II Conversion Kit



Lochinvar, LLC
300 Maddox Simpson Parkway
Lebanon, Tennessee 37090
P: 615.889.8900 / F: 615.547.1000
Lochinvar.com

