

WGVL Warren Globe Valve Linkage

For use with EV, RV and AVK Series Actuators



Technical Data	
Service	chilled or hot water and steam
Applicable valve size	2" [50], 2-½" [65], 3" [80], 4" [100], 5" [125], 6" [150]
Stem	316 stainless steel
Frame, plate, base	aluminum, steel (fits Warren Type 20,22,23,30, and 32) (Belimo G6 & G7 series)
Collar	steel
Stem adaptor	steel
Stroke	1.25" [32 mm] AVK, 2" [50 mm] EV/RV
Mounting position	360°
Media temp range (water)	20°F to 250°F [-7°C to +120°C]
Media temp range (steam)	32°F to 388°F [0°C to 170°C]
Housing material	aluminum die cast and plastic casing
Weight	2.59 lbs

Application

The WGVL retrofit kit is designed to easily attach AVK, EV and RV series actuators to select Warren® globe valves. The cast base and lower lock nut allow the WGVL to be mounted on 2-½" to 6" two-way or three-way valves in both normally open and normally closed configurations.

Default/Configuration

The default set up for a WGVL linkage will be factory installed along with an AVK or EV, RV series actuator. Included in the kit is all the necessary hardware to facilitate mounting to the Warren valve.

Operation

The WGVL linkage with actuator will provide 50 mm of linear travel to accommodate a wide range of valve sizes.

Suitable Actuators

Linkage	Non-Spring Return	Electronic Fail-Safe
WGVL	EV, RV	AVK

Dimensions (Inches [mm]) with EV and RV Series Actuators

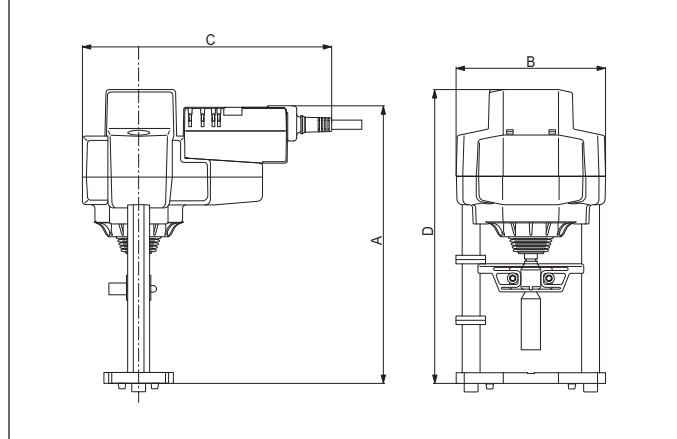

A	B	C	D
10.2" [259]	5.5" [140]	9.2" [233]	12.22" [310]

Dimensions (Inches [mm]) with AVK Series Actuators

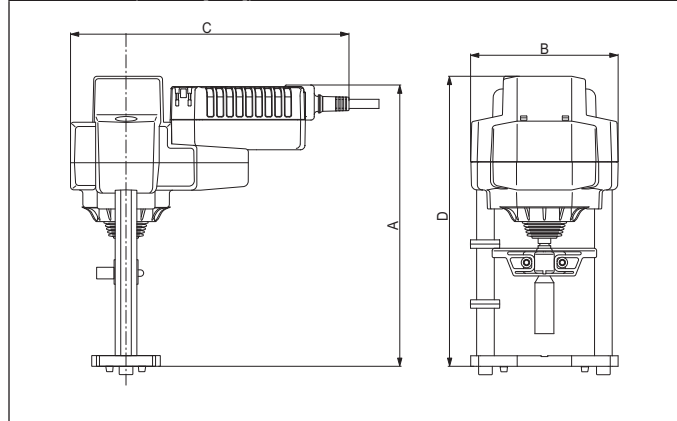

A	B	C	D
10.4" [264]	5.5" [140]	10.3" [262]	12.22" [310]

Application Notes

**Consult pages 93-113 of the Retrofit Technical Documentation and/or SelectPro for close-off pressures and a cross reference of each valve.

Tech.Doc - 07/14 - Subject to change. © Belimo Aircontrols (USA), Inc.



MFT



Technical Data	
Power supply	24 VAC ± 20% 50/60 Hz, 24 VDC ± 10%
Power consumption running	12 W
Power consumption holding	3 W
Transformer sizing	21 VA (class 2 power source)
Electrical connection	3 ft, 18 GA plenum rated cable with 1/2" conduit connector protected NEMA 2 (IP54)
Overload protection	electronic throughout full stroke
Electrical protection	actuators are double insulated
Control	Proportional/MFT
Operating Range Y	2 to 10 VDC, 4 to 20 mA (default), variable (VDC, PWM, floating point, on/off)
Input impedance	100 k Ω for 2 to 10 VDC (0.1 mA), 500 Ω for 4 to 20 mA, 1500 Ω for PWM, floating point and On/Off
Feedback Output U	2 to 10 VDC, 0.5 mA max, VDC variable
Stroke	1.25" [32 mm]
Linear Force	450 lbf [2000 N]
Direction of rotation	reversible with switch
Position indication	stroke indicator on bracket
Manual override	5 mm hex crank (3/16" Allen), supplied
Running time motor	90 seconds (default), variable (90 to 150 seconds)
Running time fail-safe	35 seconds
Humidity	5 to 95% RH non condensing
Ambient temperature	-22°F to +122°F [-30°C to +50°C]
Storage temperature	-40°F to +176°F [-40°C to +80°C]
Housing	NEMA 2, IP54, UL enclosure type 2
Housing material	Aluminum die cast and plastic casing
Bridge Time	2 second delay before fail-safe activates
Initial Charge	5 to 20 seconds
Agency listings†	cULus acc. to UL 60730-1A/-2-14, CAN/CSA E60730-1:02, CE acc. to 2004/108/EC and 2006/95/EC
Noise level	<60dB(A)
Servicing	maintenance free
Quality standard	ISO 9001
Weight	9 lbs

† Use flexible metal conduit. Push the Listed conduit fitting device over the actuator's cable to butt against the enclosure. Screw in conduit connector. Jacket the actuators input wiring with Listed flexible conduit. Properly terminate the conduit in a suitable junction box. Rated impulse Voltage 800V. Type of action 1. Control Pollution Degree 3.

Application

Fail-safe for multiple control types of globe valves in HVAC steam and hydronic systems.

Actuator sizing will be dictated by the valve size selection. All valve selections should be done in accordance with the flow parameters and system specifications. The actuator is mounted directly to the globe valve bonnet by means of its universal clamp and collar.

The actuator operates in response to many controls types as desired by the customer and/or design control input from an electronic controller or positioner. A 2 to 10 VDC feedback signal is provided for position indication.

Operation

The actuator is not provided with and does not require any limit switches, but is electronically protected against overload. The AVK series provides 32 mm of downward travel and a visual indicator indicates position of the actuator. When reaching the valve end position, the actuator automatically stops. The gears can be manually disengaged with a button on the actuator cover.

The AVK... series actuators use a sensorless brushless DC motor. The ASIC inside monitors and controls the actuator's rotation and provides a digital rotation sensing (DRS) function to prevent damage to the actuator in a stall condition. Power consumption is reduced in holding mode.

Add-on auxiliary switches are easily fastened directly onto the actuator body for signaling and switching functions. -SR and -MFT models will have an illuminated green Adaption/Power button to reset and relearn the valve stroke as well as indicate the actuator is powered. This feature allows the actuator to rescale itself based on the actual travel. Along with the Adaption button on -MFT models will have a yellow Status light to confirm communication.

Fail-Safe Indication

LED status indicator lights sequence:

Yellow off / Green on: operation ok, no faults

Yellow off / Green blinking: fail-safe mechanism is active

Yellow on / Green off: fault is detected

Yellow off / Green off: not in operation / capacitors charging

Yellow on / Green on: adaption running

Yellow blinking / Green on: communication with programming tool

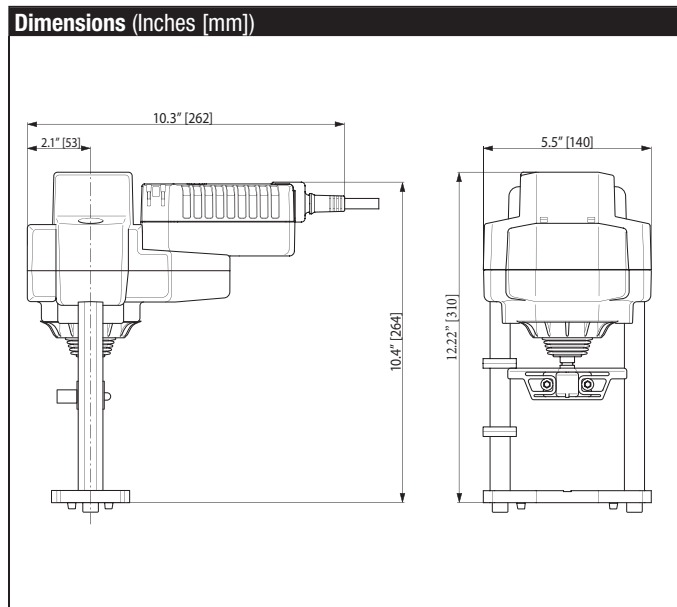

P10401 - 01/13 - Subject to change. © Belimo Aircontrols (USA), Inc.

Typical Specification

Proportional control globe valve actuators shall be electronic and direct coupled to the globe valve bonnet via an integrated linkage, which requires no secondary linkage and be capable of mounting to valves 2.5" to 6" in size. Actuators must provide control in response to a control input from an electronic controller or positioner. Actuators shall have brushless DC motor technology and be protected from overload at all angles of rotation. Actuators shall have reversing switch and manual override on the cover. Run time shall be constant and independent of torque. Actuators shall be cULus listed, have a 5-year warranty, and be manufactured under ISO 9001 International Quality Control Standards. Actuators shall be as manufactured by Belimo.

Wiring Diagrams

INSTALLATION NOTES

- 2** **CAUTION Equipment Damage!** Actuators may be connected in parallel if not mechanically mounted to the same shaft. Power consumption and input impedance must be observed.
- 3** Actuators may also be powered by 24 VDC.
- 7** a 500 Ω resistor converts the 4-20 mA control signal to 2-10 VDC
- 8** Control signal may be pulsed from either the Hot (Source) or Common (Sink) 24 VAC line.
- 9** For triac sink the common connection from the actuator must be connected to the hot connection of the controller. Contact closures A & B also can be triacs. A & B should both be closed for the triac source and open for triac sink.
- 10** For triac sink the common connection from the actuator must be connected to the hot connection of the controller. Position feedback cannot be used with a triac sink controller. The actuator internal common reference is not compatible.
- 12** IN4004 or IN4007 diode. (IN4007 supplied, Belimo part number 40155)
- 18** Actuators with plenum cable do not have numbers; use color codes instead.
- Meets cULus or UL and CSA Standard requirements without the need of an electrical ground connection.

WARNING Live Electrical Components! During installation, testing, servicing and troubleshooting of this product, it may be necessary to work with live electrical components. Have a qualified licensed electrician or other individual who has been properly trained in handling live electrical components perform these tasks. Failure to follow all electrical safety precautions when exposed to live electrical components could result in death or serious injury.

P10401 - 01/13 - Subject to change. © Belimo Aircontrols (USA), Inc.

On/Off

Floating Point

VDC/4-20 mA

Override

Functions	a	b	c
Min*	0% ←	→	↑
Mid*	50% ←	→	↑
Max*	100% ←	→	↑
Normal**	Control mode acc. to Y	→	↑

* Default selectable 0-100%. See Configuration Data Sheet.
** Customizable. See Configuration Data Sheet.