

P7640A,B Differential Pressure Sensors

INSTALLATION INSTRUCTIONS

APPLICATION

The P7640A Panel Mount and P7640B Duct Mount Differential Pressure Sensors provide reliable, accurate measurement and control. Proper applications include measurement of extremely low pressure applications such as: building/room pressure, air flow, variable air volume, filter status, and duct pressure. They are ideal for clean rooms, hospitals, fume hoods, and computer rooms.

The P7640 Pressure Sensors are designed with field-selectable 4-20 mA, 0-5 Vdc, or 0-10 Vdc output. The four pressure ranges fall between 0-1 in. w.c./0-250 Pa or 0-10 in. w.c./0-2500 Pa, depending on the model.

Accessory

32003169-001 Duct Pressure Pick-up Probe, 4 in.

INSTALLATION

When Installing this Product...

1. Read these instructions carefully. Failure to follow them could damage the product or cause a hazardous condition.
2. Check ratings given in instructions and on the product to ensure the product is suitable for your application.
3. Installer must be a trained, experienced service technician.
4. After installation is complete, check out product operation as provided in these instructions.

IMPORTANT

All wiring must agree with applicable codes, ordinances and regulations.

Mounting

Screw holes are accessed inside the enclosure (with the cover removed) and are located in the upper left and lower right corners.

Panel Mount

Run tubing from one (static) or both (differential) barb fittings, making sure the typically higher pressure source is connected to the port labeled HI, and the typically lower pressure source is connected to the port labeled LO.

Duct Mount

The units with the integral probe should typically be mounted at the high pressure location when used for differential control.

CONFIGURATION

Select the proper output, mode, and pressure range using the switches and jumpers:

1. Select output using the output switch:
 - a. Current: mA (then skip to step 3), or
 - b. Voltage: Volt.
2. Select 0-10 Vdc or 0-5 Vdc using jumper J4.
3. Select bi- or uni-directional mode using jumper J5.

NOTE: Setting for 0 to 1 in. w.c. and bi-directional will give output from -1.0 to 1.0 in. w.c.

4. Select inches w.c. or Pascal scale using jumper J7.
5. Select fast or standard response time using jumper J8.
6. Select appropriate full-scale pressure range using the rotary switch. Align arrow (not the slot) to the desired range. See Table 2 for the range selection guide.

NOTE: Note that either the 1 in. w.c. or 10 in. w.c. scale is marked. This is the available scale for that given model. When the range is changed, the LCD models momentarily indicate selected range.

7. Set output according to Table 1.

Table 1. Controller Compatibility and Output Settings.

Controller	Required Sensor Output Setting	LONSPEC™ Setting
W7750, W7760, W7761	4-20 mA	FilterPress or P7610B
W7750B, W7760C, W7753, W7760	0-10 Vdc (default)	FilterPress or P7610F, or voltage
Non-Honeywell	0-5 Vdc	n/a



WIRING (FIG. 1 THROUGH 3)

CAUTION

Equipment Damage Hazard.
Can damage the device beyond repair.
Disconnect power supply before installation.

CAUTION

Equipment Damage Hazard.
Can damage the device beyond repair.
Do not apply power to output terminal. Permanent equipment damage will result.

NOTE: Wiring to the ZERO terminals is optional.

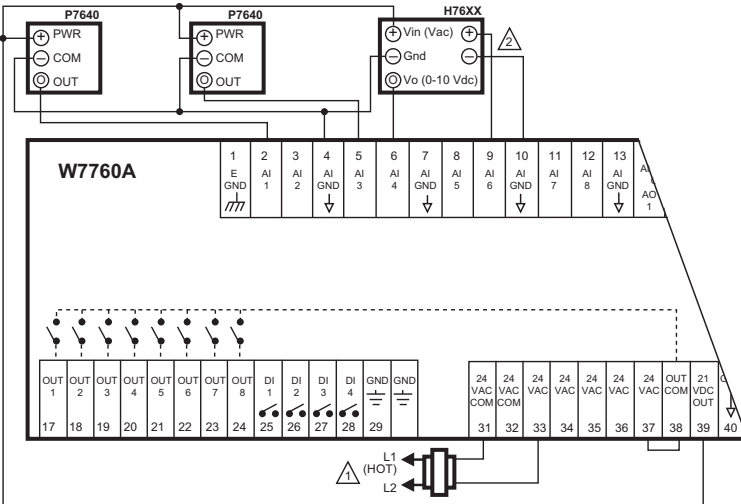
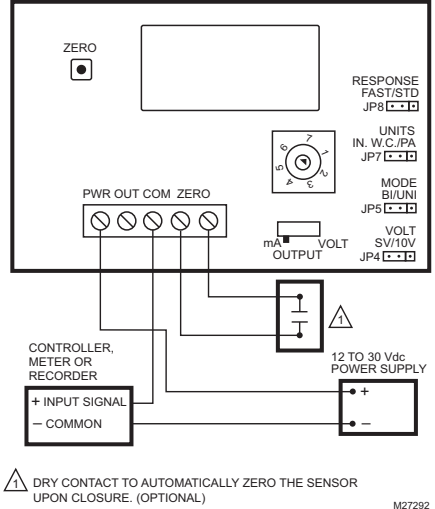
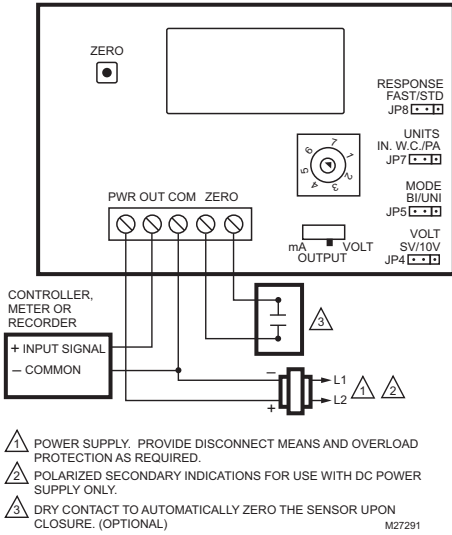

Table 2. Range Selection Guide.

Rotary Switch Position	1-in. Models		10-in. Models	
	0–1 in. w.c.	0–250 Pascal	0–10 in. w.c.	0–2500 Pascal
0	0.1	25	1	250
1	0.25	50	1	250
2	0.5	100	1	250
3	1	250	1	250
4	1	250	2.5	500
5	1	250	5	1000
6	1	250	10	2500
7	1	250	10	2500

OPERATION

IMPORTANT

During the first few minutes of operation, readings at zero pressure and lowest pressure ranges appear erroneous. Following this initial warm-up period, the P7640 maintains specified accuracy and stability.

The display momentarily indicates "SET" when a selection is made. In normal operation, pressure indications are in. w.c.

Zeroing

IMPORTANT

Perform zeroing only when both Zero ports are exposed to the same pressure.

Zeroing the device automatically resets the output and displays zero pressure. To do this either:

- Press and hold the ZERO pushbutton for 2 seconds, or
- Provide contact closure on the ZERO terminals. To ensure this, place a piece of jumper tubing between HI and LO.

NOTE: To avoid accidental zero, this feature is enabled only while detected pressure is within 5% of factory calibration.

APPENDIX

IMPORTANT

This page is only for models with date code prior to 0816.

Pre 0816 Date Code Configuration

Select the proper output, mode, and pressure range using the switches and jumpers:

1. Select output using the output switch:
 - a. Current: mA (then skip to step 3), or
 - b. Voltage: Volt.
2. Select 0-10 Vdc or 0-5 Vdc using jumper J4.
3. Select bi- or uni-directional mode using jumper J5.

NOTE: Setting for 0 to 1 in. w.c. and bi-directional will give output from -1.0 to 1.0 in. w.c.

4. Select appropriate full-scale pressure range using the slide switch.

NOTE: Note that either the 1 in. w.c. or 10 in. w.c. scale is marked. This is the available scale for that given model. When the range is changed, the LCD models momentarily indicate selected range.

WIRING (FIG. 4 THROUGH 5)

CAUTION

Equipment Damage Hazard. Can damage the device beyond repair.
Disconnect power supply before installation.

NOTE: Wiring to the ZERO terminals is optional.

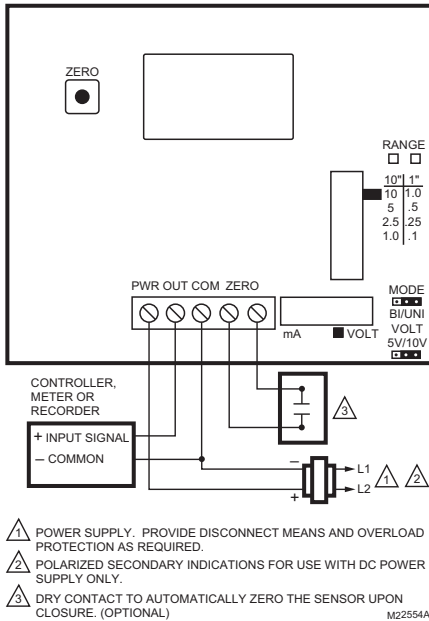

Fig. 4. Wiring for voltage (Vdc) output.

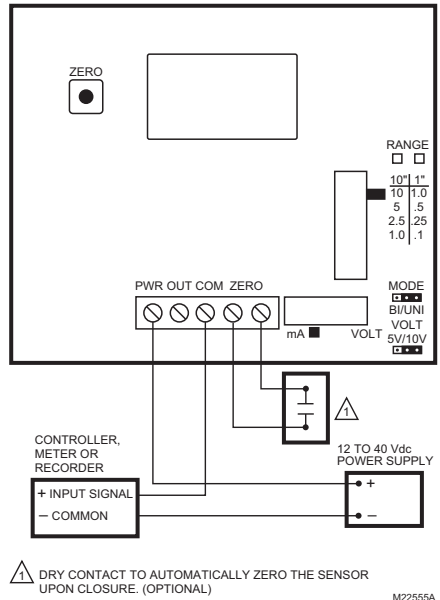

Fig. 5. Wiring for current (mA) output.

LonSpec™ is a trademark of Echelon® Corporation.

Automation and Control Solutions

Honeywell International Inc.
1985 Douglas Drive North
Golden Valley, MN 55422
customer.honeywell.com

By using this Honeywell literature, you agree that Honeywell will have no liability for any damages arising out of your use or modification to, the literature. You will defend and indemnify Honeywell, its affiliates and subsidiaries, from and against any liability, cost, or damages, including attorneys' fees, arising out of, or resulting from, any modification to the literature by you.

Honeywell

© U.S. Registered Trademark
© 2014 Honeywell International Inc.
62-0210-07 M.S. Rev. 07-14
Printed in United States