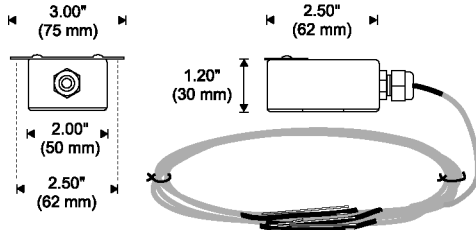
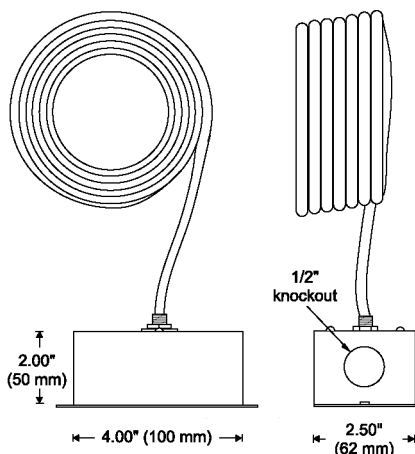
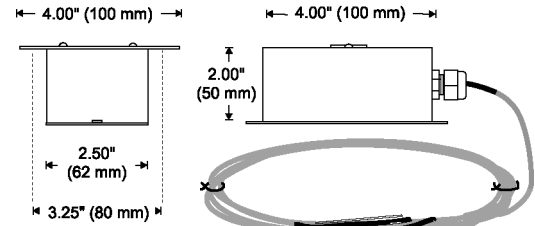

Ordering Information

INSTALLATION	SENSOR	PROBE LENGTH	PROBE TYPE
705 A Polycarb plastic enclosure IP-54	1 100-ohm platinum RTD	F 6 feet/ 1.8 m	1 Bendable 3/8" aluminum
	3 1,000-ohm platinum RTD	G 12 feet/ 3.6 m	
705 B Galvanized steel enclosure NEMA-1/IP-30	4 1,000-ohm nickel RTD	H 24 feet/ 7.2 m	2 Multiple sensors, plenum cable
	5 1,000-ohm balco RTD		
705 C Painted steel enclosure NEMA-4/IP-65	7 10,000-ohm NTC thermistor		
	10 3,000-ohm NTC thermistor		
	12 10,000-ohm NTC thermistor		
	13 5,000-ohm NTC thermistor		
	15 100,000 NTC thermistor		
	17 20,000-ohm NTC thermistor		
	18 2,252-ohm NTC thermistor		
21 1,800-ohm NTC thermistor			

Dimensions

Figure 1. TE 705 A Dimensions

Figure 2. TE 705 B 1 Dimensions

Figure 3. TE 705 C 2 Dimensions
Specifications

Platinum RTD Sensors: $\pm 0.1\%$ @ 32°F (0°C), Alpha: 385 per DIN 43760

Nickel RTD Sensors: $\pm 0.5^\circ\text{F}$ @ 70°F (21.1°C), 6,000 PPM/K T.C.R.

Balco RTD Sensors: $\pm 0.5^\circ\text{F}$ @ 70°F (21.1°C), 4,300 PPM/K T.C.R.

Thermistor Sensors: $\pm 0.2^\circ\text{C}$ interchangeability @ 77°F (25°C)

Operating Temperature: -40°F to 250°F (-40°C to 125°C)

Probe Material: 3/8-inch aluminum

Cable: Plenum rated

Plastic Enclosure: Polycarbonate, 30% glass filled, rated UL 94V-5-0

Steel NEMA-1/IP-30: 18 Ga. stainless steel

Steel NEMA-4/IP-65: 18 Ga. cold-rolled steel, powder coated

Installation
Before Installation

- Read these instructions carefully. Failure to do so can result in damage or electrical shock.
- Inspect packaging for signs of damage. If damaged, notify the carrier immediately.
- Verify that the sensor specifications are suitable for the particular application.
- Installers must be trained and qualified technicians.
- **Important:** All wiring must be compatible with applicable codes, ordinances, and instructions.

Location

Install the sensor in a location where it will sample the average duct air temperature. Avoid areas where the air is stratified because these areas can cause sensing errors.

Aluminum Probe Type

1. Drill a 3/8-inch (9 mm) hole into the duct where the sensor will be installed.
2. Gently uncoil the sensor's rigid probe and insert it into the duct.
3. Use the flange as a template to mark and drill two holes for the #8 self-tapping sheet metal screws (not provided).

4. Fasten the sensor to the duct with the sheet metal screws. See Figure 3.

Multiple Sensors, Plenum Cable

1. Drill a 3/8-inch (9 mm) hole into the duct where the sensor will be installed.
2. Unravel the sensor's cable and insert it into the duct.
3. Use the mounting bracket as a template to mark and drill two holes for the #8 self-tapping sheet metal screws (not provided).
4. Fasten the sensor to the duct with the sheet metal screws. See Figure 3.

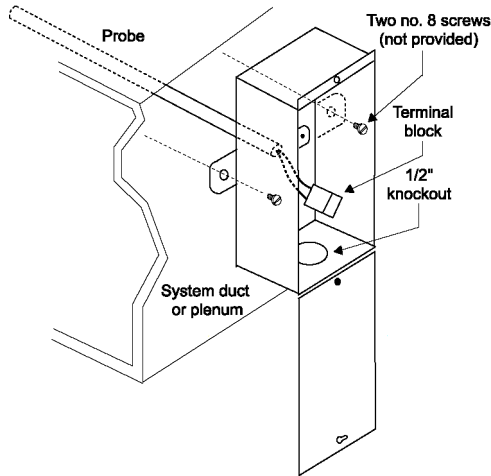

Figure 3. Installing the Duct Temperature Sensor

Checkout

Allow the sensor to stabilize in the duct air stream for a minimum of five minutes before taking a resistance measurement.

1. Disconnect the sensor lead wires from the controller.
2. Connect an ohmmeter across the lead wires.
3. Ensure that nominal resistance measurements are in accordance with the resistance / temperature curves.
4. Reconnect sensor lead wires to the controller.
5. Check operation of the complete control system.

Warranty

See the accompanying data sheet for additional information. For technical or application assistance, contact the nearest office.

EUROPE
Baird House, Units 6 & 7 Dudley Innovation Centre Pensnett Estate • Kingswinford West Midlands • DY6 8XZ United Kingdom 01384-271113 • Fax 01384-271114

AUSTRALIA
4 Armiger Court, Unit 2 Holden Hill • S.A. 5088 Australia 08-8359-4333 • Fax 08-8395-4433

ASIA
No. 22 Lorong 21A Geylang #11-02 Chin Hin Hang Building Singapore • 388431 65-6392-7273 • Fax 65-6392-7276

CANADA
155 McIntosh Drive, Unit 5 Markham • Ontario • L3R 0N6 Canada 905-474-9215 • Fax 905-474-0876

Copyright © MAMAC Systems 2003. All rights reserved.
MAMAC Systems reserves the right to change any specifications without notice to improve the performance, reliability, or function of our products.

Table 1. Resistance Versus Temperature

°F	°C	Type 1 RTD	Type 3 RTD	Type 4 RTD	Type 5 RTD	Type 7 thermistor	Type 10 thermistor
72	22.2	108.66	1,086.6	1,006.0	1,004.4	11,194	3,392
72.5	22.5	108.76	1,087.6	1,007.5	1,005.5	11,068	3,350
73	22.8	108.87	1,088.7	1,009.0	1,006.6	10,943	3,309
73.5	23	108.98	1,089.8	1,010.5	1,007.6	10,820	3,269
74	23.3	109.09	1,090.9	1,012.0	1,008.7	10,698	3,229
74.5	23.6	109.19	1,091.9	1,013.5	1,009.8	10,578	3,189
75	23.9	109.30	1,093.0	1,015.1	1,011.0	10,459	3,150
75.5	24.1	109.41	1,094.1	1,016.6	1,012.1	10,343	3,112
76	24.4	109.52	1,095.2	1,018.1	1,013.2	10,227	3,074
76.5	24.7	109.62	1,096.2	1,019.6	1,014.3	10,113	3,037
77	25	109.73	1,097.3	1,021.1	1,015.4	10,000	3,000
77.5	25.3	109.84	1,098.4	1,022.6	1,016.5	9,889	2,964
78	25.5	109.95	1,099.5	1,024.1	1,017.6	9,779	2,928
78.5	25.8	110.06	1,100.1	1,025.6	1,018.7	9,671	2,890
79	26.1	110.17	1,101.7	1,027.2	1,019.8	9,563	2,858
79.5	26.4	110.27	1,102.7	1,028.7	1,020.9	9,458	2,823
80	26.7	110.38	1,103.8	1,030.2	1,022.1	9,353	2,789
80.5	27	110.49	1,104.9	1,031.7	1,023.2	9,250	2,756
81	27.2	110.60	1,106.0	1,033.3	1,024.3	9,148	2,723
81.5	27.5	110.70	1,107.0	1,034.8	1,025.4	9,045	2,690
82	27.8	110.81	1,108.1	1,036.3	1,026.5	8,943	2,658

Table 2. Resistance Versus Temperature

°F	°C	Type 12 thermistor	Type 13 thermistor	Type 15 thermistor	Type 17 thermistor	Type 18 thermistor	Type 21 thermistor
72	22.2	11,307	5,654	113,080	22,825	2,546	2,005
72.5	22.5	11,169	5,584	111,680	22,525	2,515	1,983
73	22.8	11,031	5,515	110,300	22,226	2,484	1,962
73.5	23	10,896	5,448	108,960	21,935	2,454	1,941
74	23.3	10,762	5,381	107,620	21,645	2,424	1,920
74.5	23.6	10,631	5,316	106,320	21,362	2,394	1,899
75	23.9	10,501	5,251	105,020	21,080	2,365	1,879
75.5	24.1	10,374	5,188	103,760	20,806	2,336	1,859
76	24.4	10,247	5,124	102,480	20,532	2,308	1,839
76.5	24.7	10,123	5,062	101,240	20,266	2,280	1,819
77	25	10,000	5,000	100,000	20,000	2,252	1,800
77.5	25.3	9,880	4,940	98,800	19,741	2,225	1,791
78	25.5	9,760	4,880	97,600	19,483	2,198	1,762
78.5	25.8	9,643	4,821	96,420	19,232	2,171	1,743
79	26.1	9,526	4,763	95,260	18,981	2,145	1,725
79.5	26.4	9,412	4,706	94,120	18,737	2,119	1,707
80	26.7	9,298	4,649	92,980	18,494	2,094	1,689
80.5	27	9,187	4,616	92,320	18,257	2,069	1,671
81	27.2	9,077	4,583	91,660	18,020	2,044	1,653
81.5	27.5	8,969	4,507	90,140	17,790	2,020	1,636
82	27.8	8,861	4,431	88,620	17,560	1,996	1,619

For complete resistance versus temperature tables, please refer to TI.700-11.