



# ICM 441

## Motor Protector



### Installation, Operation & Application Guide

For more information on our complete range of American-made products – plus wiring diagrams, troubleshooting tips and more, visit us at [www.icmcontrols.com](http://www.icmcontrols.com)



## Table of Contents

|  |   |
|--|---|
| Specifications .....   | 1 |
| Mode of Operation .....  | 2 |
| ICM441 System Wiring Diagram.....  | 2 |
| Installation .....   | 3 |
| Bypassing a Sensor .....   | 5 |
| Bypassing a Sensor Wiring Diagram .....                                    | 6 |
| Troubleshooting .....  | 7 |
| Step-Down Transformer (Typical System)<br>Wiring Diagram 120-460 VAC ..... | 8 |
| Step-Down Transformer (Typical System)<br>Wiring Diagram 120-240 VAC ..... | 9 |

## Caution

***Installation of the ICM441 shall be performed by trained technicians only.  
Adhere to all local and national electric codes.***

***Disconnect all power to the system before making any connections.***

# Specification

## ENVIRONMENTAL

### Epoxy Encapsulated:

- For use in extreme environmental conditions

### Connection Terminals:

- 0.25" male spade terminals

### Temperature Range:

- -40°C to 85°C (storage)
- -40°C to 70°C (operating)

### Maximum Operating/Storage Relative Humidity:

- 95% non-condensing

### Sensor Shorted, Open, Over Temperature Detection:

- 0.1 second maximum

### Power Loss Detection:

- 0.1 second maximum

### Nominal anti-short cycle Time:

- 4 minutes (+/- 60 seconds)

### Case Dimensions:

- 3"L x 3.25"W x 1.5"H

## ELECTRICAL

### User Selectable Operating Voltage:

- 90-140 VAC RMS and 185-270 VAC RMS (based on field wiring)

### Low Voltage Cutout:

- 85 (+/-5.5) VAC RMS (using 120 VAC input)
- 170 (+/-10) VAC RMS (using 208 VAC input)

### Over Temperature Trip:

- Any one sensor input in excess of 11KW (+/- 1KW)

### Over Temperature Reset:

- All three sensor inputs must be less than 3KW (+/- 500W)

### Shorted Sensor Trip:

- Any one sensor input less than 250W (+/- 50W)

### Shorted Sensor Reset:

- All three sensor inputs must be greater than 500W (+/- 100W)

### N.O. Relay Contact Rating (M1, M2):

- 2.5 amps resistive @ 277 VAC RMS
- 2.5 amps inductive @ 277 VAC RMS

### Low Power Consumption:

- 23mA (nominal) @ 120 VAC @ 25°C
- 21mA (nominal) @ 240 VAC @ 25°C

### Terminal "L2" is Not Internally Connected:

- Provided for backward compatibility to competitor models
- Not required for new installations

### Temperature Sensors:

- Monitors industry standard (3BA and 10BA sensors)

## ICM441 Cross Reference Guide

| ICM # | T.I. #     | Mars # | Copeland #  | Bristol # |
|-------|------------|--------|---|-----------|
| 441   | 31AA1606 E |        |   | 241680    |
|       | 15AA1603 B | 37304  | <b>Replaces:</b> 071-9800-01<br><b>Used On:</b> Copeland: GR, SE  |           |
|       | 15AA1603 C | 37306  | <b>Replaces:</b> 071-9800-00<br><b>Used On:</b> Copeland: GR, SE  |           |
|       | 31AA1600 E | 37322  | <b>Replaces:</b> 071-0376-01 071-0397-00 071-0424-00<br>071-0376-02 071-0397-01 071-0424-01<br><b>Used On:</b> Copeland: 4R, 6R, BR, M, 2D, 3D, 4, 6, 8,<br>both Reed & Discus models |           |
|       | 15AA1600 B | 37300  | <b>Replaces:</b> 071-0376-02 071-0397-01 071-0424-01<br><b>Used On:</b> Copeland: 4R, 6R, BR  |           |
|       | 15AA1600 C | 37302  | <b>Replaces:</b> 071-0376-01 071-0397-00<br><b>Used On:</b> Copeland: 4R, 6R, BR  |           |

## Mode of Operation

The ICM441 is designed to individually monitor 3 PTC temperature sensors which are wound into each phase winding of a motor. If any winding or incoming line power is beyond the safe operating range of the motor, the ICM441 will lock the motor out of operation until the inputs fall back into the safe operating range. The ICM441 can sense shorted or open sensors, in addition to providing isolation to each sensor to prevent damage to the monitor in the event a sensor shorts to a winding or case ground.

## ICM441 System Wiring Diagram

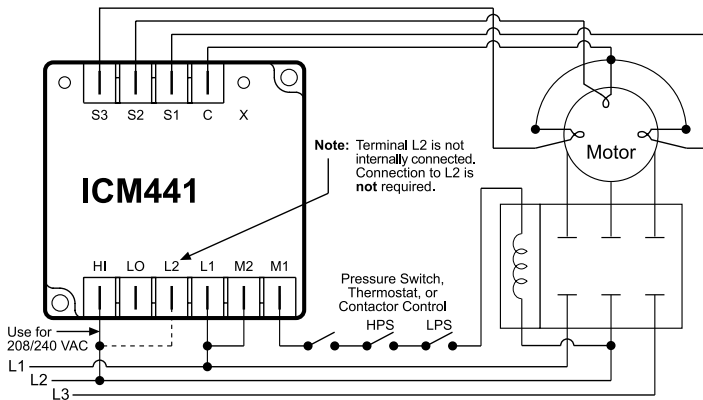

## Installation

This installation is only to be performed by a qualified electrician in accordance with NEC standards.

Ensure all power to both motor and control circuits is removed before starting installation. Verify there is no voltage present with a voltmeter.

This control is typically installed on a three phase motor, where the power for this control comes directly off one set of phases to the motor (see System Wiring Diagram). If you have an installation where a step-down transformer drops the voltage supply for this control, please see the section titled "Step-Down Transformer Installations."

In applications where this control replaces an existing motor protector of the same voltage and sensor ratings, label each wire connected to the defective unit before you remove it from that control. Terminal designations should correspond to terminals on the ICM441.

### **Step 1: Verify sensor integrity**

There should be four (4) small gage wires coming from the motor housing, which connect to internally-wound sensors. There are three sensor wires, and one sensor common wire. At normal temperature, a motor which has been de-energized for at least one hour will have sensors with a normal operating resistance of approximately 1KW. A sensor must be in the range of 500W to 3KW when measured with a resistance meter between the sensor common wire and each sensor wire (S1, S2, and S3). If a sensor is found outside of this range, you must deactivate that sensor from all sensing, as described in the section labeled "Bypassing A Sensor."

### **Step 2: Connect all sensor wires**

There should be four (4) small gage wires coming from the motor housing, which connect to internally-wound sensors. There are three sensor wires, and one sensor common wire. The sensor common wire connects with female 1/4" quick-connects to the ICM441 terminal "C" (common). All of the individual sensor wires connect to the ICM441 terminals "S1, S2, and S3" with female 1/4" quick-connects.

Connect sensor wire S1 to terminal "S1," connect sensor wire S2 to terminal "S2," and connect sensor wire S3 to terminal "S3." The order of these sensors is not important, simply ensure that each sensor wire is connected to a sensor input on the ICM441. Consult the System Wiring Diagram should any other questions arise.

### **Step 3: Connect the control circuit**

There is always a contactor that supplies operating current to the motor this device protects. This contactor has an internally wound coil with a specific operating voltage rating. Ensure the operating voltage rating of this coil is in the range of 24 VAC to 277 VAC, since the ICM441 has a maximum rating of 277 VAC on its internal control contacts.

Usually, one side of the contactor coil is connected to power common. Whether a transformer is used to step-down the control voltage (see the section titled “Step-Down Transformer Installations”) or if it is powered by line voltage, one side of the coil is typically connected directly to this common. Leave this connection to the contactor coil as is.

The other side of the contactor coil typically is energized by “hot” through a series of switches, usually by some type of thermostat, pressure switch, or safety switch. Remove this “switched side” coil wire from the contactor coil and connect to the ICM441 terminal “M2” using a 1/4” female quick-connect. Fashion another wire with female 1/4” quick-connects on both ends to connect between the ICM441 terminal “M1” and the “switched side” of the coil you just removed the wire from. Consult the System Wiring Diagram should any other questions arise.

### **Step 4: Supply operating voltage to the ICM441**

The operating voltage required for this unit is 120/240 VAC, 50/60 Hz. Determine what voltage range will be supplied to the ICM441 and connect voltage as follows:

- 85-135 VAC: Connect Neutral (or “common” on step-down transformer applications) to the terminal labeled “L1” on the ICM441, via a 1/4” female quick-connect. Connect L1 (or “hot” on step-down transformer applications) to the terminal labeled “LO” on the ICM441, via a 1/4” female quick-connect. You may connect an additional wire between terminals “LO” and “L2” on the ICM441, but this option is not required. Terminal “L2” has no internal connection, it is provided for backward compatibility to other models of motor protector.
- 185-277 VAC: Connect L1 (or “common” on step-down transformer applications) to the terminal labeled “L1” on the ICM441, via a 1/4” female quick-connect. Connect L2 (or “hot” on step-down transformer applications) to the terminal labeled “HI” on the ICM441, via a 1/4” female quick-connect. You may connect an additional wire between terminals “HI” and “L2” on the ICM441, but this option is not required. Terminal “L2” has no internal connection, it is provided for backward compatibility to other models of motor protector.

Consult the System Wiring Diagram should any other questions arise. Your ICM441 is now ready for application of power to the motor and control circuits.

## Bypassing A Sensor

Since these sensors are internally wound into the winding of the motor, they are not field-replaceable. In the event that the resistance of a sensor is found to be outside of the 500W to 3KW range, the sensor must be properly bypassed in order for this motor protector to function.

To bypass a sensor, you must disconnect the defective sensor's wire from the ICM441, and connect a 1/2-Watt 1.0KW to 2.0KW resistor from terminal "C" to the open sensor terminal. These resistors can be purchased at any electrical hobby shop, such as Radio Shack. Consult the "Bypassing a Sensor" wiring diagram for an illustrative explanation.

### Bypassing A Sensor Wiring Diagram

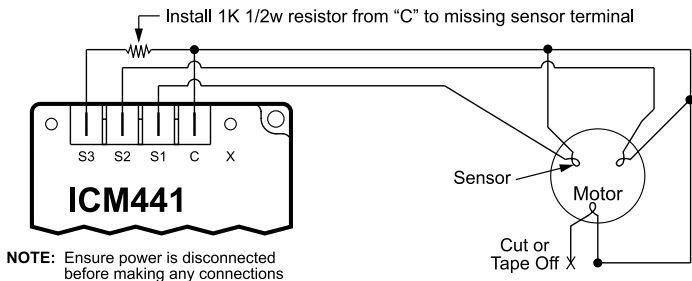

## Troubleshooting

| Problem                                   | Possible Cause  | Corrective Action  |
|---|---|--|
| Motor does not energize                   | Your control circuit is not calling for motor to energize | Measure voltage across terminals M1 and M2. A 0 Volt reading indicates either ICM441's contacts are closed OR your control circuit is not calling. Check safety switches or thermostat.  |
|   | Incorrect voltage range selected to power input of ICM441 | Rewire ICM441 as listed above  |
|   | Incoming voltage is low                                   | Measure between L1 and LO (120 VAC) or L1 and HI (208-240 VAC). Spec is $85 \pm 5.5$ VAC (120 VAC) or $170 \pm 10$ VAC (208-240 VAC). It may also be possible that the motor pulls down the line <b>AFTER</b> it is energized. Measure line voltage with contactor closed. |
|   | Sensor is out of specification                            | Allow motor to cool if sensor is $> 3KW$ . Bypass sensor if sensor resistance is $> 25KW$ . Bypass sensor if sensor resistance is $< 500W$ . Sensor may be shorting to a winding or to ground during operation, repair as necessary.                                       |
| Motor turns off right after energized     | Low voltage   | Ensure voltage does not drop below spec when motor is energized. Measure voltage between L1 and LO or HI during motor start.   |
|   | Bad sensor  | Sensor may be shorting to a winding or chassis during motor operation. Measure resistance of sensors while bypassing terminals M1 and M2. Bypass sensor if required.   |
| Motor turns off after running for a while | Winding overheating                                       | Check for phase unbalance or phase loss to motor. Check for low-voltage during operation. Control circuit may have also opened, check pressure switches or thermostat.   |
| Motor was on, but will not re-energize    | Anti-Short-Cycle Timer                                    | Wait 5-minutes for built-in anti-short-cycle timer to time out. Defeat anti-short cycle timer by shorting terminal "C" to hidden terminal "X."   |
| Motor was on, but will not re-energize    | Motor over temperature                                    | Verify motor temperature with a temperature probe. Measure resistance of sensors, if any sensor was over 10K-ohms, the ICM441 will not reset until ALL sensors return below 3-Kohms.   |



## Step-Down Transformer Typical System Wiring Diagram (120-460 VAC)

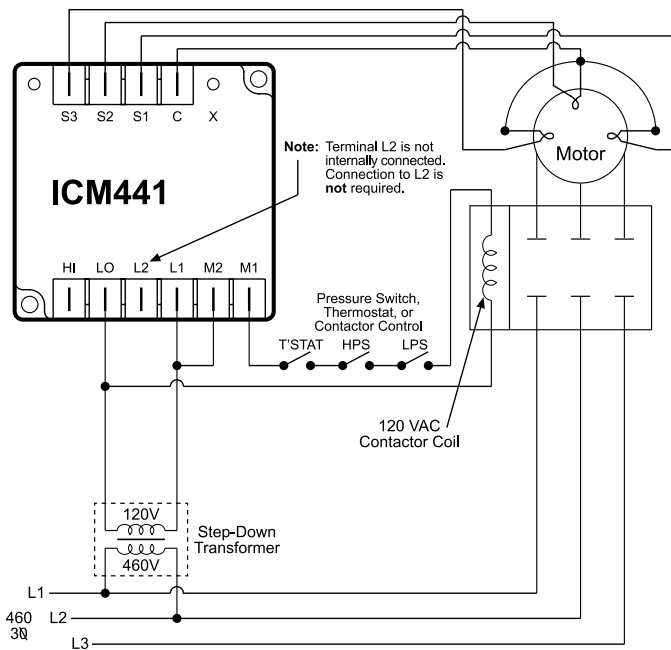

**Step-Down Transformer Powering ICM441 and Contactor**

## Step-Down Transformer Typical System Wiring Diagram (120-240 VAC)

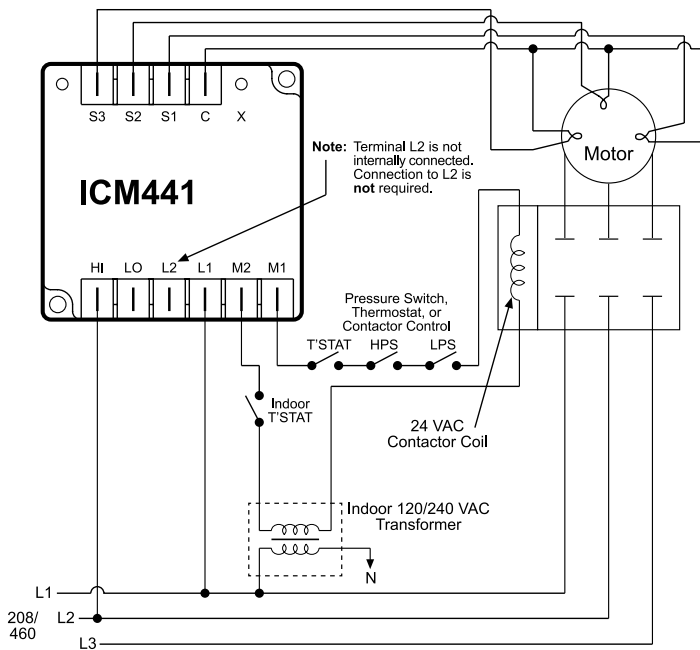

**Step-Down Transformer Powering ICM441 and Contactor**

# ONE-YEAR LIMITED WARRANTY

The Seller warrants its products against defects in material or workmanship for a period of one (1) year from the date of manufacture. The liability of the Seller is limited, at its option, to repair, replace or issue a non-case credit for the purchase prices of the goods which are provided to be defective. The warranty and remedies set forth herein do not apply to any goods or parts thereof which have been subjected to misuse including any use or application in violation of the Seller's instructions, neglect, tampering, improper storage, incorrect installation or servicing not performed by the Seller. In order to permit the Seller to properly administer the warranty, the Buyer shall: 1) Notify the Seller promptly of any claim, submitting date code information or any other pertinent data as requested by the Seller. 2) Permit the Seller to inspect and test the product claimed to be defective. Items claimed to be defective and are determined by Seller to be non-defective are subject to a \$30.00 per hour inspection fee. This warranty constitutes the Seller's sole liability hereunder and is in lieu of any other warranty expressed, implied or statutory. Unless otherwise stated in writing, Seller makes no warranty that the goods depicted or described herein are fit for any particular purpose.



**7313 William Barry Blvd., North Syracuse, NY 13212**  
**(Toll Free) 800-365-5525 (Phone) 315-233-5266 (Fax) 315-233-5276**

[www.icmcontrols.com](http://www.icmcontrols.com)

LIA214