

Data sheet

Solenoid valves for R 410A and R744 (CO₂)

EVR 2 to EVR 8 and EVRH 10 to EVRH 40



EVR 2 and EVR 3 (direct operated) and EVR 4 to EVR 8 / EVRH 10 to EVRH 40 (servo-operated) are high pressure solenoid valves specially designed to meet the requirements of high pressure refrigerants such as R410A and R744 (CO₂). The EVRH valve can be used for liquid, suction and hot gas lines.

Features

- Normally Closed and Normally Open
- Coils for AC and DC voltages
- Suitable for R410A and R744 (CO₂)
- Media temperatures up to 221°F
- Design pressure 655 psig
- MOPD up to 350 psi
- Solder connections up to 7/8 inch
- Extended soldering ends
- Solders without dismantling the valve

Approvals

The Low Voltage Directive (LVD) 2014/35/EU with amendments EN 60730-2-8.



Technical data

Temperature of medium

-40 – 105 °C for 10 or 12 W coil
 Max. 130 °C during defrost
 -40 – 80 °C for 20 W coil

Refrigerants

R744, R22/R407C, R404A/R507, R410A, R134a, R407A, R23, R744.

For other refrigerants, please contact Danfoss.

Note: EVR 2 – EVR 3 and EVRH 25 – EVRH 40 are not suitable for R744 (CO₂) applications with media temperatures constantly below 0 °C.

For other media temperatures, please contact Danfoss.

Type	Opening differential pressure Δp [psig] (with standard coil)			C _v value [gal/min]
	Min. ODP	MOPD		
		14 – 17 W AC	20 W DC	
EVR 2	0	350	260	0.19
EVR 3	0	300	260	0.32
EVR 4	0.7	300	260	0.7
EVR 6	0.7	300	260	0.92
EVR 6 NO	0.7	300	300	0.92
EVR 8	0.7	300	260	1.3
EVRH 10	0.7	300	260	2.2
EVRH 15	0.7	300	260	3.0
EVRH 20	0.7	300	190	5.8
EVRH 22	0.7	300	190	6.9
EVRH 25	1.0	300	260	12
EVRH 32	1.0	300	260	18
EVRH 40	1.0	300	260	29

Ordering

EVR / EVRH Valves

Solenoid valve – Normally Closed (NC) – Soldering ODF without coil

Type	Coil type	Connection size [in.]	Code no.
EVR 2	AC/DC	1/4	032F7100
EVR 3	AC/DC	1/4	032F7105
	AC/DC	3/8	032F1157
EVR 4	AC/DC	3/8	032F7110
	AC/DC	1/2	032F7111
EVR 6	AC/DC	3/8	032F7115
	AC/DC	1/2	032F1162
	AC/DC	5/8	032F7117
EVR 8	AC/DC	1/2	032F7121
	AC/DC	5/8	032F7122
EVRH 10	AC/DC	1/2	032G1077
EVRH 15	AC/DC	5/8	032G1078
EVRH 20	AC	7/8	032G1079
EVRH 25	AC/DC	1 1/8	032G1059
EVRH 32 ¹⁾	AC/DC	–	032G1081
EVRH 40	AC/DC	1 5/8	032G1062

¹⁾ Only available with mm connections

Solenoid valve – Normally Open (NO)

Type	Coil type	Connection size [in.]	Code no.
EVR 6	AC/DC	3/8	032F1164
EVRH 10	AC/DC	1/2	032F1329

BJ and BX Coils



Coil type	Wire length		Voltage [V AC]	Frequency [Hz]	Power consumption [W]	Code no.
	[in.]	[cm.]				
Junction box NEMA 2						
BJ024CS	7	18	24	50 / 60	14	018F4100
BJ120CS	7	18	110 – 120 110	60	15	018F4110
				50	16	
BJ240CS	7	18	208 – 240 230	60	14	018F4120
				50	17	
BJ120BS	7	18	120	60	16	018F4130
BJ208BS	7	18	208	60	16	018F4132
BJ240BS	7	18	240	60	16	018F4134
Conduit boss NEMA 4						
BX024CS	18	46	24	50 / 60	14	018F4102
BX024CS	71	180	24	50 / 60	14	018F4103
BX024CS	98	250	24	50 / 60	14	018F4104
BX120CS	18	46	110 – 120 110	60 50	15 16	018F4112
BX120CS	36	91				018F4113
BX120CS	71	180				018F4114
BX120CS	98	250				018F4115
BX240CS	18	46	208 – 240 230	60 50	14 17	018F4122
						98
BX120BS	98	250	120	60	16	018F4131
BX208BS	98	250	208	60	16	018F4133
BX240BS	98	250	240	60	16	018F4135

Technical data
Design

In accordance with UL 429

Power supply

Alternating current (AC)

Permissible voltage variation

Alternating current (AC):

50 Hz and 60 Hz: -10% – 15%

50/60 Hz: ± 10%

Power consumption

Alternating current (AC): Inrush: 49 VA;

Holding: 28 VA, 14 – 17 W

Insulation of coil wire

Class H according to IEC 85

Connection

Junction box or Conduit boss

Enclosure, IEC 60529

Junction box NEMA 2 ~ IP 12–32

Conduit boss NEMA 4 ~ IP 54

Ambient temperature

-40 °F – 122 °F (-40 °C – 50 °C)

Capacity, R410A
Liquid capacity

Type	Liquid capacity Q ₀ tons at pressure drop across valve p psi						
	1	2	3	4	5	6	7
EVR 2	0.56	0.78	0.96	1.1	1.23	1.35	1.46
EVR 3	0.98	1.37	1.68	1.93	2.15	2.36	2.55
EVR 4	2.12	2.98	3.65	4.2	4.69	5.14	5.55
EVR 6	2.79	3.92	4.8	5.52	6.16	6.75	7.3
EVR 8	3.94	5.54	6.78	7.8	8.7	9.54	10.3
EVRH 10	6.63	9.31	11.4	13.1	14.6	16	17.3
EVRH 15	9.07	12.7	15.6	17.9	20	21.9	23.7
EVRH 20	17.5	24.5	30	34.5	38.5	42.2	46.6
EVRH 22	20.82	29.4	36	41.4	46.2	50.6	54.8
EVRH 25	33.65	47.59	58.29	67.31	75.25	82.44	89.04
EVRH 32	53.85	76.15	93.27	107.69	120.41	131.90	142.47
EVRH 40	84.14	118.99	145.73	168.27	188.13	206.09	222.60

Capacities are based on:
liquid temperature t_l = 100 °F

Evaporating temperature t_e = 40 °F
Superheat 10 °F

Capacity, R410A
Suction vapour capacity

Type	Pressure drop Δp [psi]	Suction vapour capacity Q ₀ tons at evaporating temperature t _e °F							
		-40	-20	0	10	20	30	40	50
EVR 2	1	0.04	0.05	0.07	0.07	0.08	0.09	0.10	0.11
	2	0.06	0.07	0.09	0.11	0.12	0.13	0.14	0.16
	3	0.07	0.09	0.12	0.13	0.14	0.16	0.18	0.19
EVR 3	1	0.07	0.09	0.12	0.13	0.14	0.16	0.18	0.20
	2	0.10	0.13	0.16	0.18	0.21	0.23	0.25	0.28
	3	0.12	0.16	0.20	0.23	0.25	0.28	0.31	0.34
EVR 4	1	0.15	0.20	0.25	0.28	0.31	0.35	0.39	0.43
	2	0.22	0.28	0.36	0.40	0.45	0.49	0.55	0.60
	3	0.27	0.35	0.44	0.49	0.55	0.61	0.67	0.74
EVR 6	1	0.20	0.26	0.33	0.37	0.41	0.46	0.51	0.56
	2	0.29	0.37	0.47	0.53	0.59	0.65	0.72	0.79
	3	0.35	0.46	0.58	0.65	0.72	0.80	0.88	0.97
EVR 8	1	0.28	0.36	0.46	0.52	0.57	0.64	0.71	0.78
	2	0.41	0.52	0.66	0.74	0.82	0.91	1.01	1.10
	3	0.49	0.64	0.81	0.91	1.01	1.12	1.23	1.36
EVRH 10	1	0.48	0.62	0.79	0.89	0.98	1.09	1.20	1.33
	2	0.68	0.88	1.12	1.25	1.39	1.54	1.70	1.87
	3	0.84	1.08	1.37	1.54	1.71	1.89	2.09	2.30
EVRH 15	1	0.66	0.85	1.09	1.21	1.35	1.50	1.65	1.81
	2	0.93	1.21	1.53	1.72	1.91	2.11	2.33	2.56
	3	1.14	1.48	1.88	2.10	2.33	2.59	2.85	3.14
EVRH 20	1	1.27	1.64	2.09	2.33	2.59	2.88	3.17	3.49
	2	1.79	2.32	2.95	3.30	3.67	4.06	4.48	4.93
	3	2.20	2.85	3.61	4.04	4.49	4.98	5.49	6.04
EVRH 22	1	1.51	1.95	2.49	2.77	3.08	3.43	3.77	4.15
	2	2.13	2.76	3.51	3.93	4.37	4.83	5.33	5.87
	3	2.62	3.39	4.29	4.81	5.34	5.92	6.53	7.19
EVRH 25	1	2.46	3.23	4.13	4.63	5.16	5.72	6.33	6.96
	2	3.39	4.50	5.78	6.49	7.25	8.05	8.91	9.82
	3	4.04	5.42	7.01	7.89	8.82	9.81	10.87	11.98
EVRH 32	1	3.93	5.17	6.61	7.40	8.25	9.16	10.12	11.14
	2	5.42	7.20	9.25	10.39	11.60	12.89	14.26	15.70
	3	6.46	8.68	11.22	12.62	14.11	15.70	17.38	19.17
EVRH 40	1	6.15	8.08	10.32	11.57	12.90	14.31	15.82	17.41
	2	8.47	11.25	14.45	16.23	18.12	20.14	22.27	24.54
	3	10.09	13.56	17.53	19.72	22.05	24.53	27.16	29.95

Note: Bold figures refer to rated capacity

The table values refer to evaporator capacity and are given as a function of evaporating temperature t_e and pressure drop Δp across the valve. Capacities are based on liquid temperature t_l = 100 °F ahead of the expansion valve and superheat t_s = 7 °F. For each additional 10 °F of superheat, the table capacities must be reduced by 2%.

Correction factors for liquid temperature t_l
When liquid temperature t_l ahead of the expansion valve is other than 100 °F, adjust the table capacities by multiplying them by the appropriate correction factor found in the following table:

t _l °F	80	90	100	110	120
Factor	1.10	1.05	1.00	0.95	0.90

Capacity R410A
Hot gas capacity

Type	Pressure drop p [psi]	Hot gas capacity Q _h tons at evaporating temp. t _e =40 °F. hotgas temp. t _h =t _c +40 °F. subcooling t _u =10 °F	
		Condensing temperature t _c °F	
		70	100
EVR 2	2	0.19	0.20
	5	0.30	0.31
	10	0.42	0.44
	15	0.52	0.54
	20	0.60	0.62
EVR 3	2	0.33	0.34
	5	0.52	0.54
	10	0.74	0.76
	15	0.90	0.94
	20	1.04	1.08
EVR 4	2	0.72	0.75
	5	1.13	1.17
	10	1.61	1.65
	15	1.97	2.02
	20	2.27	2.33
EVR 6	2	0.94	0.98
	5	1.49	1.55
	10	2.11	2.19
	15	2.59	2.68
	20	2.98	3.10
EVR 8	2	1.31	1.37
	5	2.08	2.17
	10	2.95	3.06
	15	3.62	3.75
	20	4.17	4.33
EVRH 10	2	2.24	2.33
	5	3.54	3.68
	10	5.02	5.20
	15	6.14	6.36
	20	7.08	7.36
EVRH 15	2	3.07	3.18
	5	4.85	5.03
	10	6.86	7.11
	15	8.40	8.70
	20	9.69	10.00
EVRH 20	2	5.90	6.12
	5	9.32	9.68
	10	13.2	13.7
	15	16.1	16.7
	20	18.6	19.3
EVRH 22	2	7.02	7.28
	5	11.1	11.5
	10	15.7	16.3
	15	19.2	19.9
	20	22.1	23.0
EVRH 25	2	12.95	13.91
	5	20.32	21.89
	10	28.34	30.70
	15	34.22	37.28
	20	38.94	42.68
EVRH 32	2	20.73	22.26
	5	32.51	35.02
	10	45.34	49.12
	15	54.75	59.65
	20	62.30	68.29
EVRH 40	2	32.39	34.78
	5	50.79	54.72
	10	70.85	76.75
	15	85.54	93.20
	20	97.34	106.70
	25	107.21	118.25

Hot gas capacity values in the table are given as a function of condensing temperature t_c and pressure drop across the valve Δp .

Capacities are based on gas superheated 40 °F above condensing temperature,

$$(t_h = t_c + 40 \text{ °F})$$

For each additional 10 °F of superheat above 40 °F, the table capacities must be reduced by 1%.

In a hot gas defrost circuit, evaporator temperature affects valve capacity.

When the evaporator temperature differs from 40 °F, adjust the table capacities by multiplying them by applying a correction factor from the following table.

Correction factors for t_h and t_c

t_e °F	-40	-20	0	20	40	50
Factor	1.18	1.14	1.09	1.04	1	0.97

Note: The MOPD is depending on the choice of coil, please refer to page 4.

Capacity R744 (CO₂)

With CO₂ EVRH valves can only be used in subcritical applications.
For CO₂ capacity tables, refer to Cool selector® or contact your local Danfoss office.

Note: EVR 2-3 and EVRH 25-40 are not suitable for R744 (CO₂) applications with media temperatures constantly below 0 °C. For other media temperatures, please contact Danfoss.

Design and Function

- 4. Coil
- 16. Armature
- 18. Valve plate/ Pilot valve plate
- 20. Ground terminal
- 28. Gasket
- 29. Pilot orifice
- 40. Protective cap, Junction box
- 43. Valve cover
- 45. Valve cover gasket
- 49. Valve body
- 73. Equalization port
- 80. Diaphragm and servo piston
- 83. Valve seat
- 90. Mounting hole

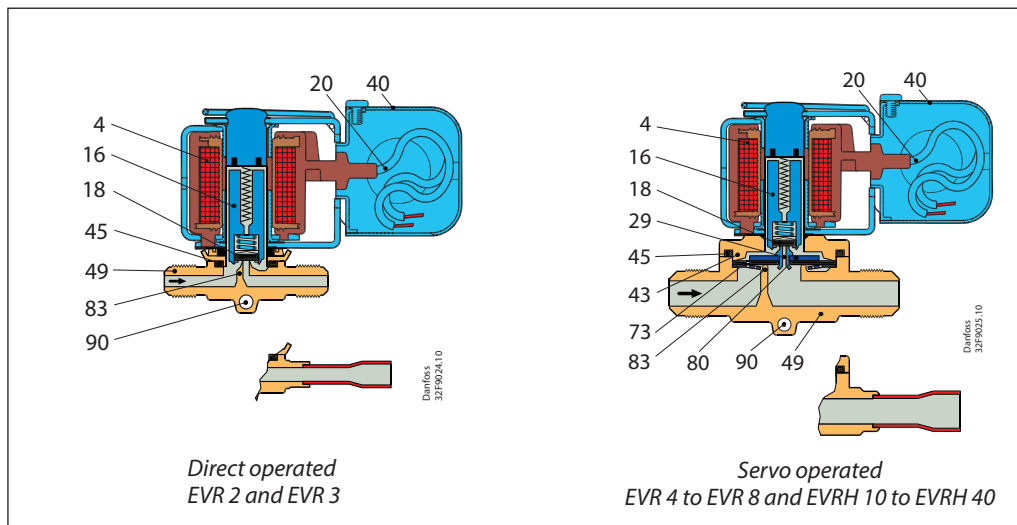

EVRH solenoid valves are designed on two different principles:

1. Direct operation
2. Servo operation

1. Direct operation

EVR 2 and EVR 3 are direct operated. The valves open directly for full flow when the armature (16) moves up into the magnetic field of the coil. This means that the valves operate with a min. differential pressure of 0 bar. The valve plate (18) is fitted directly on the armature (16). Inlet pressure acts from above on the armature and the valve plate. Thus, inlet pressure, and spring force act to close the valve when the coil is currentless.

2. Servo operation

EVR 4 to EVR 8 and EVRH 10 – EVRH 20 are servo operated with a “floating” diaphragm (80). The pilot orifice (29) is placed in the centre of the diaphragm. The pilot valve plate (18) is fitted direct to the armature (16). When the coil is currentless, the main orifice and pilot orifice are closed. The pilot orifice and main orifice are held closed by the armature spring force and the differential pressure between inlet and outlet sides. When current is applied to the coil the armature is drawn up into the magnetic field and opens the pilot orifice. This relieves the pressure above the diaphragm, i.e. the space above the diaphragm becomes connected to the outlet side of the valve.

The differential pressure between inlet and outlet sides then presses the diaphragm away from the main orifice and opens it for full flow. Therefore a certain minimum differential pressure is necessary to open the valve and keep it open. For EVR 4 to EVR 8 and EVRH 10 – EVRH 20 valves this differential pressure is 0.05 bar. When current is switched off, the pilot orifice closes. Via the equalization holes (73) in the diaphragm, the pressure above the diaphragm then rises to the same value as the inlet pressure and the diaphragm closes the main orifice.

EVRH 25 – EVRH 40 are servo operated piston valves. The valves are closed with currentless coil. The servo piston (80) with main valve plate (84) closes against the valve seat (83) by means of the differential pressure between inlet and outlet side of the valve and the force of the compression spring (76).

When current to the coil is switched on, the pilot orifice (29) opens. This relieves the pressure on the piston spring side of the valve. The differential pressure will then open the valve. The minimum differential pressure needed for full opening of the valves is 0.2 bar.

Material specifications

EVR 2 – EVR 8 and EVRH 10 – EVRH 25

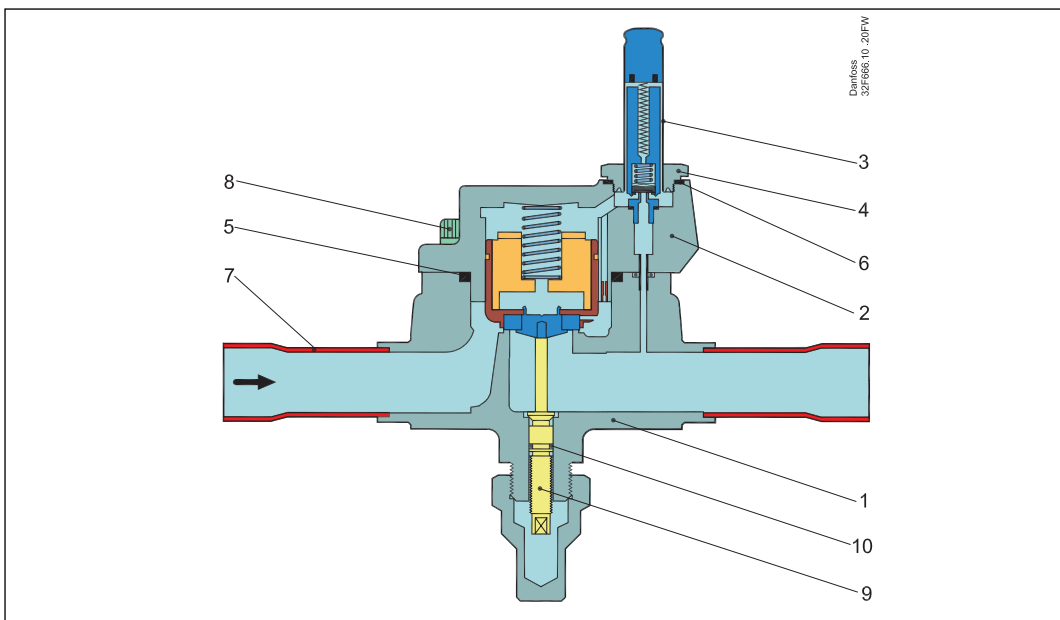
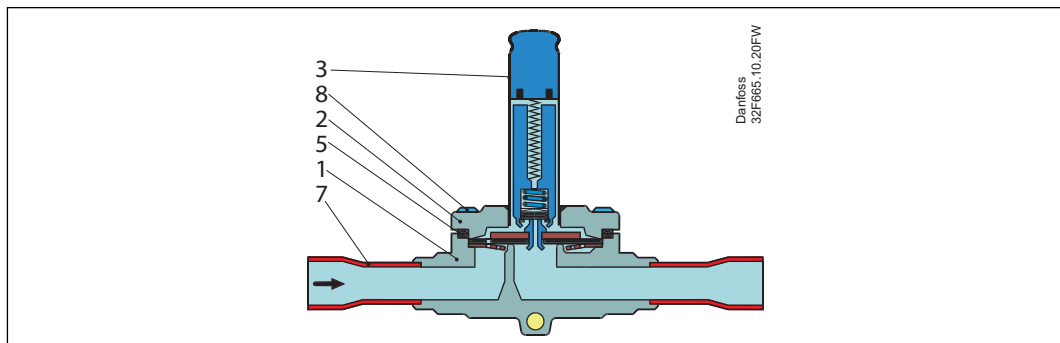

No.	Description	Material
1	Valve body	Brass
2	Cover	Stainless steel
		Brass
		Cast iron
3	Armature tube	Stainless steel
4	Armature tube nut	Stainless steel
5	Gasket	Rubber
6	Gasket	Al. gasket
7	Solder tube	Copper
8	Screws	Stainless steel
9	Spindle for man. operat.	Stainless steel
10	Gasket	Rubber

Material specifications
(continued)

EVRH 32 – EVRH 40

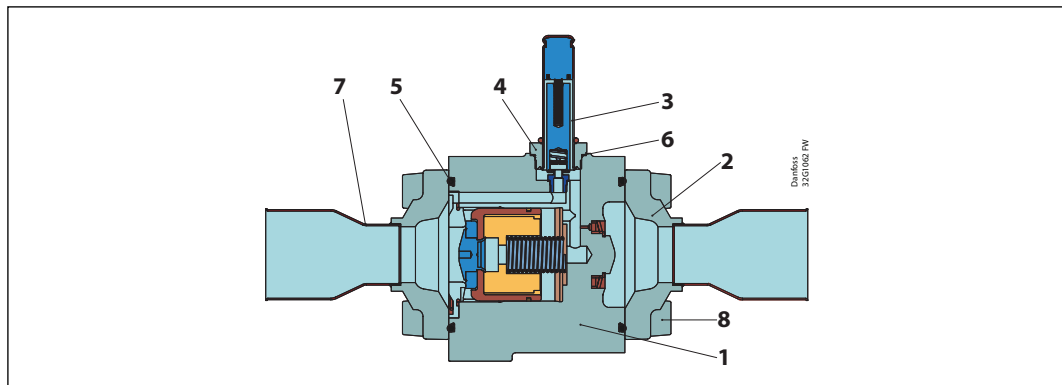

No.	Description	Material
1	Valve body	Cast Iron
2	Cover	Brass
3	Armature tube	Stainless steel
4	Armature tube nut	Stainless steel
5	Gasket	Rubber
6	Gasket	Al. gasket
7	Solder tube	Bi-metallic tube
8	Screws	Stainless steel

Dimensions and weight

EVR 2 – 6 and EVRH 10 – 20

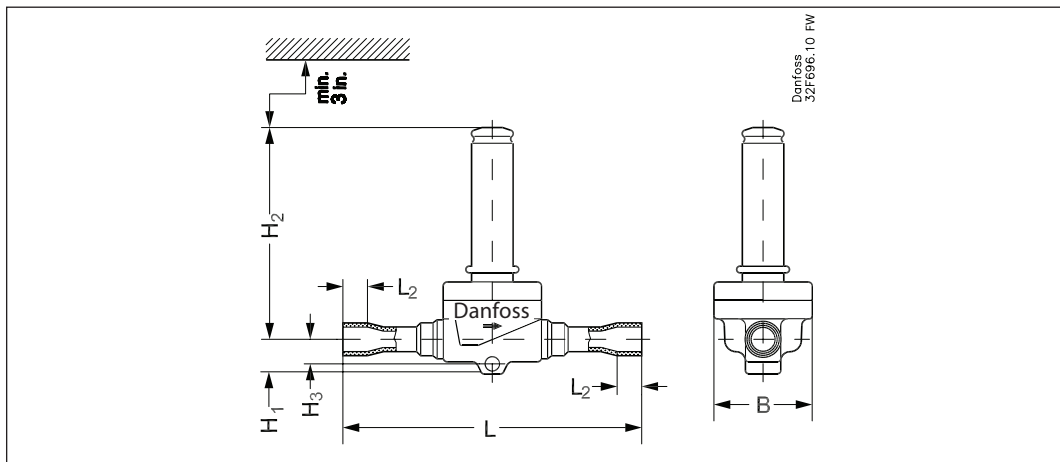

EVRH 25

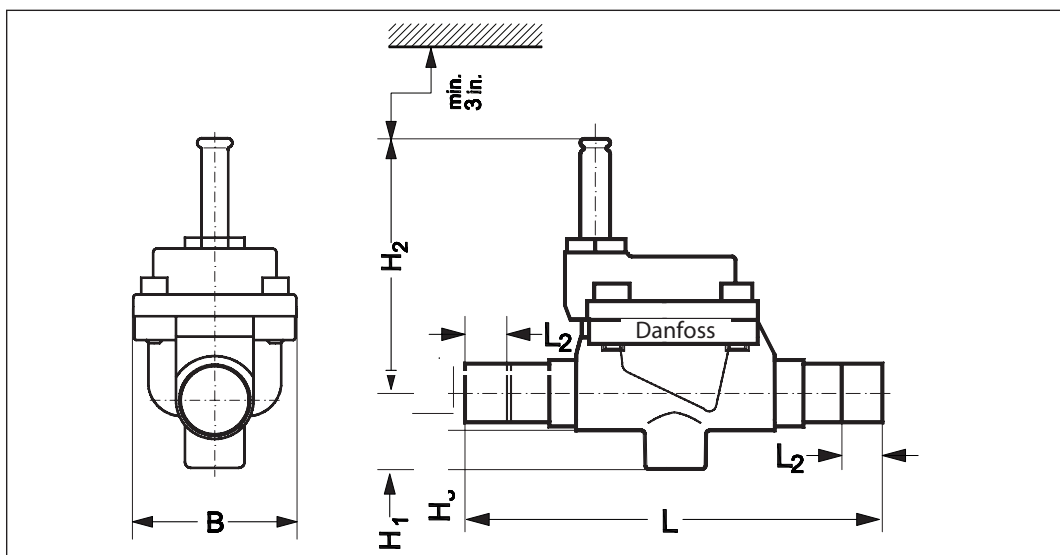

EVRH 32

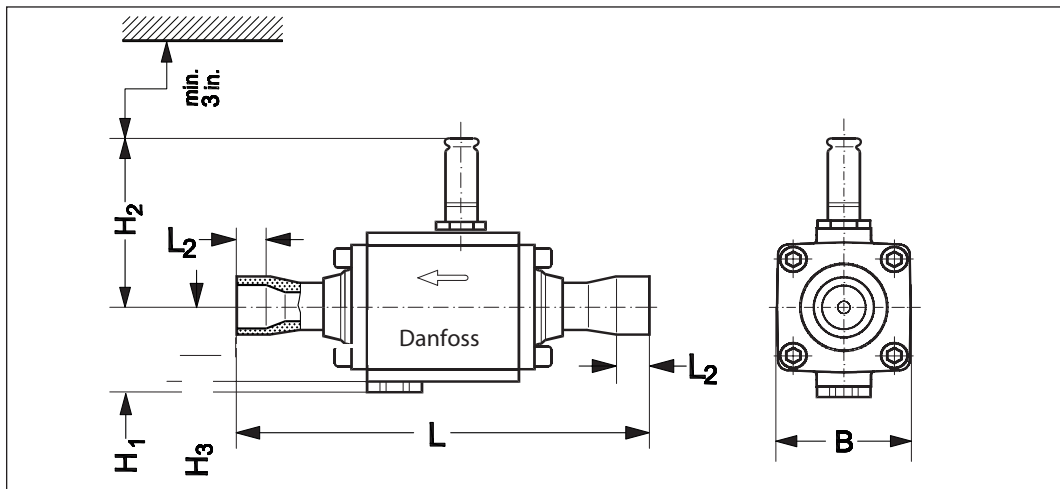

EVRH 40

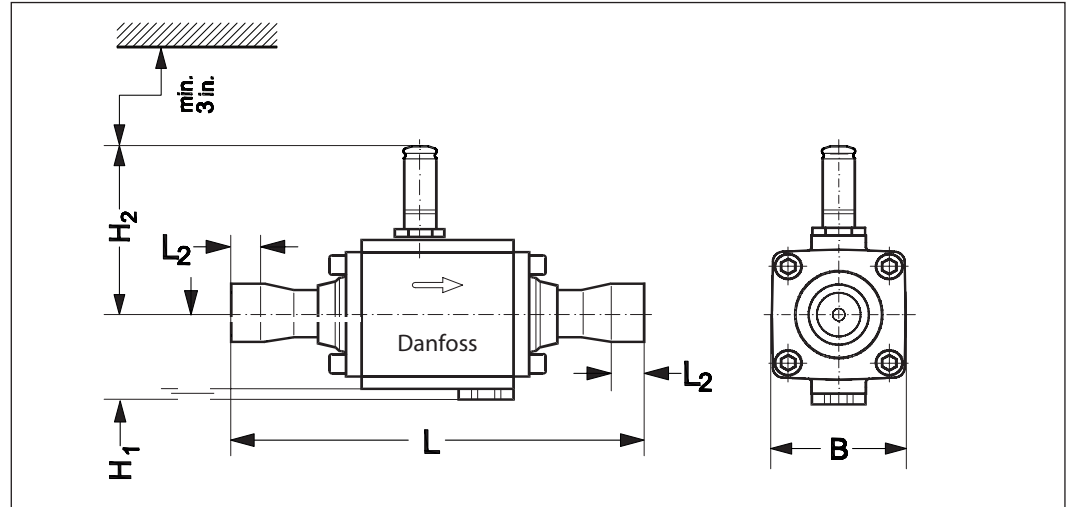

EVRH 25, EVRH 32 – 40, solder connection

Type	Solder connection [in]	H ₁ [in]	H ₂ [in]	H ₃ [in]	L [in]	L ₂ [in]	B [in]	Weight [lbs]
EVR 2	¼ lbs	⅙	2 ½	⅙	4	⅜	1 ⅙	0.44
EVR 3	⅙	⅙	2 ½	⅙	4	⅜	1 ⅙	0.44
	⅜	⅙	2 ½	⅙	4 ⅝	⅙	1 ⅙	0.44
EVR 4	⅜	⅙	2 ¾	⅜	4 ¼	⅙	1 ⅙	–
	½	⅙	2 ¾	⅜	5	⅜	1 ⅙	–
EVR 6	⅜	⅙	2 ¾	⅜	4 ¼	⅙	1 ⅙	0.66
	½	⅙	2 ¾	⅜	5	⅜	1 ⅙	0.66
EVR 8	⅝	⅙	2 ¾	⅜	6	½	1 ⅙	0.66
	½	⅙	2 ¾	⅜	5	⅜	1 ⅙	–
EVR 8	⅝	⅙	2 ¾	⅜	6	½	1 ⅙	–
EVRH 10	½	⅝	3	⅞	5	⅜	1 ⅜	1.10
EVRH 15	⅝	¾	3 ¼	–	6 ⅜	½	2 ⅜	1.76
EVRH 18	–	¾	3 ¼	–	–	–	2 ⅜	–
EVRH 20	⅞	29/32	3 ⅙	–	7 ½	⅝	2 ⅜	2.20
EVRH 22	⅞	29/32	3 ⅙	–	7 ½	⅝	2 ⅜	–
EVRH 25	1 ⅙	–	5 ⅙	1 ½	8 ⅙	⅞	3 ¾	3.0
EVRH 32	–	–	1 ⅙	2	9 ½	1 ⅙	3 ⅙	4.3
EVRH 40	1 ⅙	–	1 ⅙	2 ⅙	10 ¼	1 ⅙	3 ⅙	4.3

Net weight of coil: 0.67 lbs

Danfoss can accept no responsibility for possible errors in catalogues, brochures and other printed material. Danfoss reserves the right to alter its products without notice. This also applies to products already on order provided that such alterations can be made without subsequential changes being necessary in specifications already agreed. All trademarks in this material are property of the respective companies. Danfoss and the Danfoss logotype are trademarks of Danfoss A/S. All rights reserved.