

VR8304 Intermittent Pilot Combination Gas Control

INSTALLATION INSTRUCTIONS

APPLICATION

These intermittent pilot gas controls are used in gas-fired appliances with capacities up to 300 ft³/hr at 1 in. WC pressure drop (8.5 m³/h at 0.25 kPa) on natural gas. They include a manual valve, two automatic operators, and a pressure regulator. See Table 1 for temperature ranges and regulator types.

Table 1. Temperature ranges and regulator types

Model number	Ambient temperature range	Regulator type
VR8304H	0 F to 175 F (-18 C to +79 C)	Slow-opening
VR8304K	-40 F to 175 F (-40 C to +79 C)	Slow opening
VR8304M	-40 F to 175 F (-40 C to +79 C)	Standard-opening
VR8304P	-40 F to 175° F (-40 C to +79 C)	Step-opening

SPECIFICATIONS

Body pattern: Straight-through body pattern.

Inlet x outlet sizes available: 1/2 x 1/2 in., 1/2 x 3/4 in., and 3/4 x 3/4 in. (factory-installed inlet flange).

Adapters Adapters available for 3/8, 1/2 and 3/4 in. straight and angle connections. Refer to Table 2.

Electrical Ratings: voltage and frequency: 24 Vac, 50/60 Hz.

Current Draw: 0.7A.

Capacity: See Table 3.

Approvals:

- American Gas Association Design Certificate: UP-70-69A
- Canadian Gas Association Design Certificate: UP-70-69A.
- Australian Gas Association Certificate: Applied for.
- Delta C: Applied for.

Table 2. Flange part numbers

Inlet/outlet pipe size	Flange type	Part number
3/8 inch NPT	Straight	393690-11
1/2 inch NPT	Elbow	393690-13
3/4 inch NPT	Straight	393690-4
	Elbow	393690-15

NOTE: Flange kits include one flange with attached O-ring and fan mounting screw.

Table 3. Capacity

Size (inlet x outlet)	Capacity at 1 in. WC pressure drop ^a	Minimum regulated capacity	Maximum regulated capacity
1/2 x 1/2	240 ft ³ /hr (6.8 m ³ /hr)	30 ft ³ /hr (0.8 m ³ /hr)	340 ft ³ /hr (9.6 m ³ /hr)
1/2 X 3/4	270 ft ³ /hr (7.6 m ³ /hr)	30 ft ³ /hr (0.8 m ³ /hr)	370 ft ³ /hr (10.5 m ³ /hr)
3/4 X 3/4	300 ft ³ /hr (8.5 m ³ /hr)	30 ft ³ /hr (0.8 m ³ /hr)	415 ft ³ /hr (11.8 m ³ /r)

^aCapacity based on 1000 Btu/ft³, 0.64 specific gravity natural gas at 1 in. WC pressure drop (37.3 MJ/m³, 0.64 specific gravity natural gas at 0.25 kPa pressure drop.

Use conversion factors in Table 4 to convert capacities for other gases.

Table 4. Gas capacity conversion factors

Gas	Specific gravity	Multiply listed capacity by
Manufactured	0.60	0.516
Mixed	0.70	0.765
Propane	1.53	1.62



INSTALLATION

When installing this product ...

1. Read these instructions carefully. Failure to follow them could damage the product or cause a hazardous condition.
2. Check the ratings given in the instructions and on the product to ensure the product is suitable for your application.
3. Ensure installer is a trained, experienced service technician.
4. After installation is complete, use these instructions to check out product operation.

! WARNING

Fire or explosion hazard. Can cause property damage, severe injury, or death.

Follow these warnings exactly:

1. Disconnect power supply before wiring to prevent electrical shock or equipment damage.
2. To avoid dangerous accumulation of fuel gas, turn off gas supply at the appliance service valve before starting installation, and perform the gas leak test after completion of installation.
3. Do not bend pilot tubing at gas control or pilot burner after compression fitting has been tightened, or gas leakage at the connection may result.
4. Always install sediment trap in gas supply line to prevent contamination of gas control.
5. Do not force the gas control knob. Use only your hand to turn the gas control knob. Never use tools. If the gas control knob will not operate by hand, the gas control should be replaced by a qualified service technician. Force or attempted repair may result in fire or explosion.

! CAUTION

Never apply a jumper across or short the valve coil terminals. This may burn out the heat anticipator in the thermostat or damage the electronic intermittent pilot (IP) module.

IMPORTANT

These gas controls are shipped with protective seals over inlet and outlet tapplings. Do not remove the seals until you are ready to connect piping.

Follow the appliance manufacturer's instructions if available; otherwise, use the instructions provided below.

Converting Between Natural and LP Gas

! WARNING

Fire or explosion hazard. Can cause property damage, severe injury, or death.

Do not attempt to use a gas control set for natural gas on LP gas or a gas control set for LP gas on natural gas.

To convert a gas control from natural gas to LP gas or from LP gas to natural gas, contact your Honeywell representative.

Standard- or slow-opening gas controls are converted from one gas to another with a conversion kit (order separately). Order Part Number 393691 to convert from natural to LP gas. Order Part Number 394588 to convert from LP to natural gas. Step-opening gas controls cannot be converted.

Install Adapters to Gas Control

Install adapters to the gas control as follows:

Flanges

1. Choose the appropriate flange for your application.
2. Remove the seal over the gas control inlet or outlet.
3. Ensure the O-ring is fitted in the groove of the flange. If the O-ring is not attached or is missing, do not use the flange.
4. With the O-ring facing the gas control, align the screw holes on the gas control with the holes in the flange. Insert and tighten the screws provided with the flange. See Fig. 1. Tighten the screws to 25 in. pounds of torque to provide a gas-tight seal.

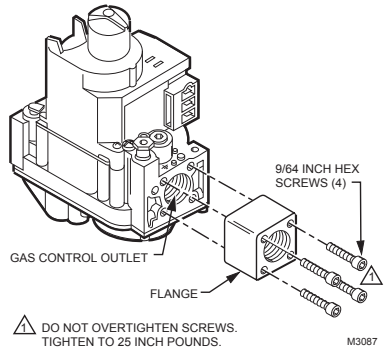

Fig. 1. Install flange to gas control.

Bushings

1. Remove the seal over the gas control inlet or outlet.
2. Apply moderate amount of good quality pipe compound to the bushing, leaving two end threads bare. On LP installation, use a compound resistant to LP gas. Do not use Teflon tape.
3. Insert the bushing into the gas control and thread the pipe carefully into the bushing until tight.

Using Adapters to Solve Swing Radius Problems

In some field service applications, it is difficult or impossible to thread the gas control onto the gas supply pipe because of space limitations. This problem can be resolved in many instances by using an adapter. The adapter is installed on the end of the supply pipe in place of the gas control, following the same precautions and instructions that are used for installing the gas control. After the adapter is installed, the gas control is attached to the adapter as outlined above. Note that using an adapter increases the overall length of the gas control.

Choose Gas Control Location

Do not locate the gas control where it may be affected by steam cleaning, high humidity, dripping water, corrosive chemicals, dust or grease accumulation, or excessive heat.

To ensure proper operation, follow these guidelines.

- Locate the gas control in a well ventilated area.
- Mount the gas control high enough above the cabinet bottom to avoid exposure to flooding or splashing water.
- Ensure the ambient temperature does not exceed the ambient temperature ratings for each component.
- Cover the gas control if the appliance is cleaned with water, steam, or chemicals or to avoid dust and grease accumulation.
- Avoid locating the gas control where exposure to corrosive chemical fumes or dripping water is likely.

Locate the gas control in the appliance vestibule on the gas manifold. In replacement applications, locate the gas control in the same location as the old gas control.

Install Piping to the Gas Control

All piping must comply with local codes and ordinances or with the National Fuel Gas Code (ANSIZ223.1 NFPA No. 54), whichever applies. Tubing installation must comply with approved standards and practices.

1. Use new, properly reamed pipe free of chips. If tubing is used, ensure the ends are square, deburred and clean. All tubing bends must be smooth and without deformation.
2. Run a pipe or tubing to the gas control. If tubing is used, obtain a tube-to-pipe coupling to connect the tubing to the gas control.
3. Install a sediment trap in the supply line to the gas control. See Fig. 2.

Install the Gas Control

1. Mount the gas control 0–90 degrees in any direction from the upright position of the gas control knob, including vertically.
2. Mount the gas control so that gas flow is in the direction of the arrow on the bottom of the gas control.
3. Thread the pipe the amount shown in Table 5 for insertion into the gas control or adapter. DO NOT THREAD THE PIPE TOO FAR. Valve distortion or malfunction may result if the pipe is inserted too deeply into the gas control.
4. Apply a moderate amount of good quality pipe compound (DO NOT use Teflon tape) to the pipe only, leaving two end threads bare. On LP installations, use a compound resistant to LP gas. Refer to Fig. 3.
5. Remove the seals over the gas control inlet and outlet if necessary.
6. Connect the pipe to the gas control inlet and outlet. Use a wrench on the square ends of the gas control. If an adapter is used, place the wrench on the adapter rather than the gas control. Refer to Figs. 4 and 5.

Table 5. NPT pipe thread length (inches)

Pipe size	Thread pipe this amount	Maximum depth pipe can be inserted into the control
3/8	9/16	3/8
1/2	3/4	1/2
3/4	13/16	3/4

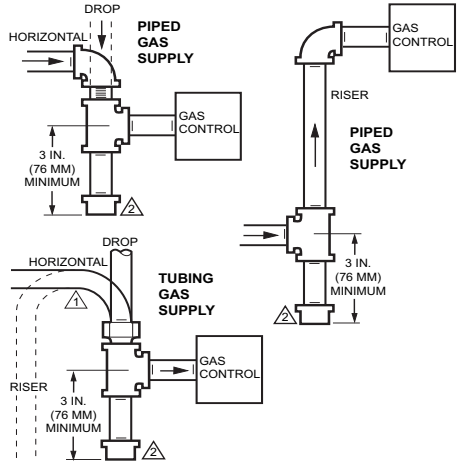

⚠ ALL BENDS IN METALLIC TUBING SHOULD BE SMOOTH.

⚠ CAUTION: SHUT OFF THE MAIN GAS SUPPLY BEFORE REMOVING END CAP TO PREVENT GAS FROM FILLING THE WORK AREA. TEST FOR GAS LEAKAGE WHEN INSTALLATION IS COMPLETE. M3077A

Fig. 2. Install a sediment trap.

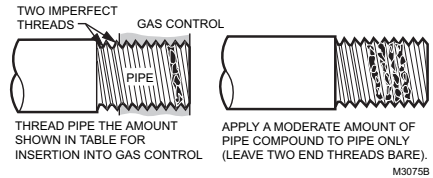

Fig. 3. Use a moderate amount of pipe compound.

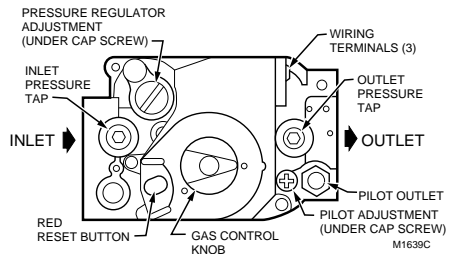

Fig. 4. Top view of gas control.

Connect Pilot Gas Tubing

1. Cut tubing to desired length and bend as necessary for routing to the pilot burner. Do not make sharp bends or deform the tubing. Do not bend tubing at gas control or pilot burner after compression fitting has been tightened, as this may result in gas leakage at the connection.
2. Square off and remove burrs from the ends of tubing.

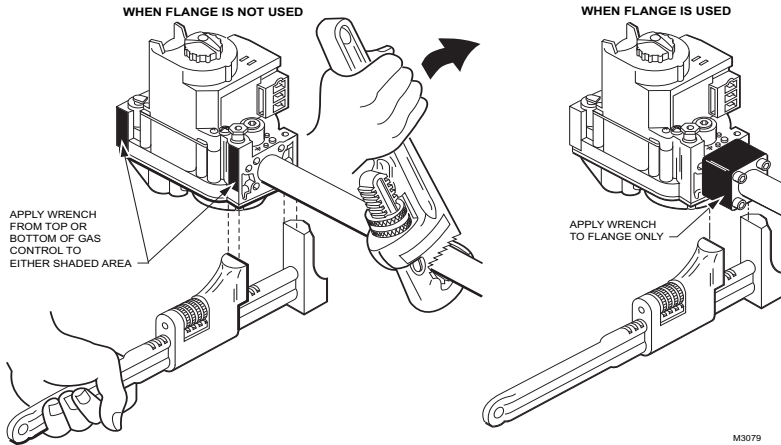

Fig. 5. Proper use of a wrench on a gas control with and without flanges.

- Unscrew compression fitting from the pilot outlet (Fig. 4).
- Slip the compression fitting over the tubing and slide out of the way.
- Push the tubing into the pilot gas tapping on the outlet end of the control until it bottoms. While holding tubing all the way in, slide compression fitting into place and engage threads—turn until finger tight. Then tighten one more turn with a wrench. Do not overtighten. Refer to Fig. 6.
- Connect other end of the tubing to pilot burner according to the pilot burner's manufacturer's instructions.
- Connect the control circuit to the gas control terminals. See Figs. 4 and 7 or 8.
- Adjust the thermostat heat anticipator to 0.70 rating stamped on valve operator.

STARTUP AND CHECKOUT

⚠ WARNING

Fire or explosion hazard. Can cause property damage, severe injury, or death.

- Do not force the gas control knob. Use only your hand to turn the gas control knob. Never use tools.
- If the gas control knob will not operate by hand, the gas control should be replaced by a qualified service technician.

Gas Control Knob Settings

The gas control knob has two settings:

- OFF—prevents pilot and main burner gas flow.
- ON—permits gas to flow into the control body. Under control of the thermostat and intermittent pilot module, pilot and main burner gas flow is permitted.

NOTE: Gas controls are shipped with the gas control knob in the ON position.

Turn on the System

Rotate the gas control knob counterclockwise ↶ to ON.

Turn on the Main Burner

Follow the instructions provided by the appliance manufacturer or turn the thermostat up to call for heat.

NOTE: When replacing a gas control, cut off old compression fitting and replace it with the new compression fitting provided on the gas control. Never use the old compression fitting as it may not provide a gas-tight seal.

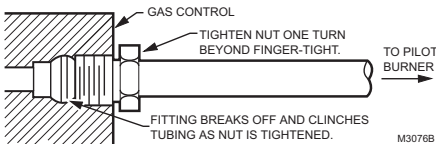

Fig. 6. Always use new compression fitting.

WIRING

Follow the wiring instructions furnished by the appliance manufacturer if available or use the general instructions provided below.

All wiring must comply with applicable electrical codes and ordinances.

Disconnect power supply before making wiring connections to prevent electrical shock or equipment damage.

- Check the power supply rating on the gas control and ensure it matches the available supply. Install transformer, thermostat, and other controls as required.

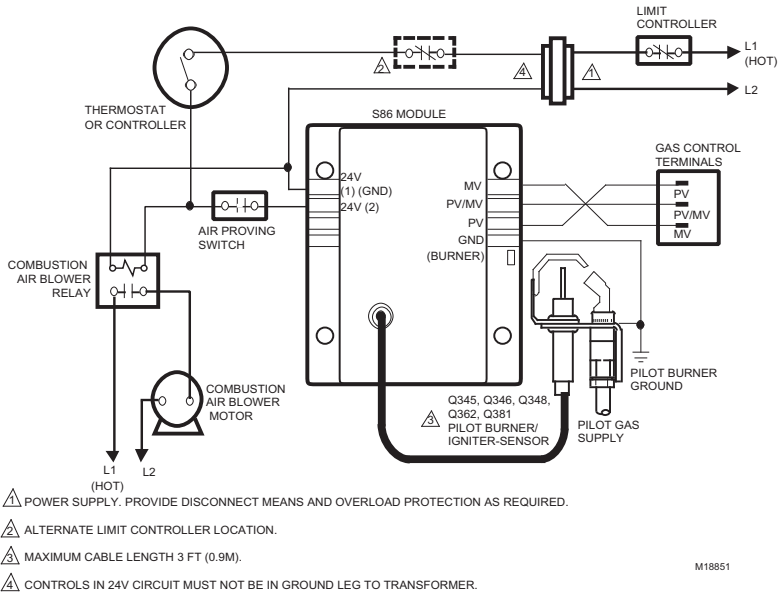

Fig. 7. VR8304 wiring connections in an intermittent ignition system with S86.

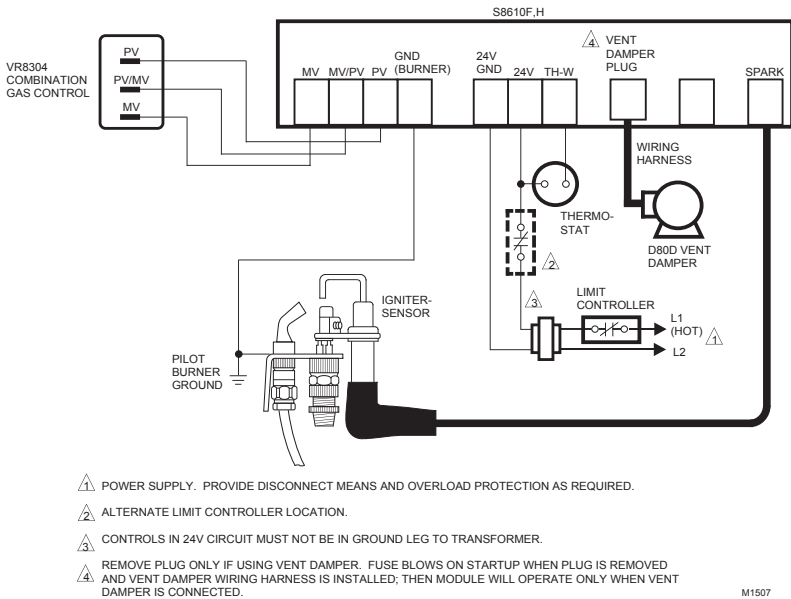

Fig. 8. VR8304 wiring connections in intermittent ignition system with S8600.

Perform Gas Leak Test

! WARNING

Fire or explosion hazard. Can cause property damage, severe injury, or death. Check for gas leaks with a rich soap and water solution any time work is done on a gas control.

Gas leak test

1. Paint all pipe connections upstream of the gas control with a rich soap and water solution. Bubbles indicate a gas leak.
2. If a gas leak is detected, tighten the pipe connection.
3. Stand clear while lighting the main burner to prevent injury caused from hidden gas leaks, which could cause flashback in the appliance vestibule. Light the main burner.
4. With the main burner in operation, paint all pipe joints (including adapters) and the gas control inlet and outlet with a rich soap and water solution.
5. If another gas leak is detected, tighten adapter screws, joints, and pipe connections.
6. Replace the part if the gas leak cannot be stopped.

Adjust the Pilot Burner Flame

The pilot flame should envelop 3/8 to 1/2 in. (10-13 mm) of the igniter sensor tip. See Fig. 9. To adjust the pilot flame:

1. Remove the pilot adjustment cover screw. Refer to Fig. 4.
2. Turn the inner adjustment screw clockwise ↻ to decrease or counterclockwise ↺ to increase the pilot flame.
3. Always replace the cover screw after adjustment and tighten firmly to ensure proper operation.

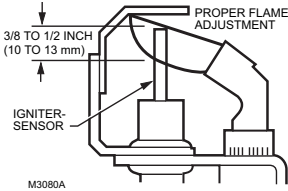

Fig. 9. Proper flame adjustment.

Check and Adjust Gas Input to Main Burner

! CAUTION

1. Do not exceed the input rating stamped on the appliance nameplate or the manufacturer's recommended burner orifice pressure for the size of orifice(s) used. Ensure the main burner primary air supply is properly adjusted for complete combustion (refer to the appliance manufacturer's instructions).
2. IF CHECKING GAS INPUT BY CLOCKING THE GAS METER:
 - Ensure that the only gas flow through the meter is that of the appliance being tested.
 - Ensure that other appliances are turned off and that their pilot burners are extinguished (or deduct their gas consumptions from the meter reading).
 - Convert the flow rate to Btuh as described in the Gas Controls Handbook (form number 70-2602)

and compare to the Btuh input rating on the appliance nameplate.

3. IF CHECKING GAS INPUT WITH A MANOMETER (PRESSURE GAUGE):
 - Ensure the gas control knob is in the PILOT position before removing the outlet pressure tap plug to connect the manometer.
 - Turn the gas control knob back to PILOT when removing the manometer and replacing the outlet pressure tap plug.
 - Shut off the gas supply at the appliance service valve or, for LP gas, at the gas tank before removing the outlet pressure tap plug and before disconnecting the manometer and replacing the outlet pressure tap plug.
 - Perform the gas leak test at the inlet pressure tap plug.

Standard-opening and slow-opening pressure regulator

1. The gas control outlet pressure should match the manifold pressure listed on the appliance nameplate.
2. With the main burner operating, check the gas control flow rate using the meter docking method or check the gas pressure using a manometer connected to the gas control outlet pressure tap. Refer to Fig. 4.
3. If necessary, adjust the pressure regulator to match the appliance rating. Refer to Table 5 or 6 for the factory set nominal outlet pressures and adjustment ranges.
 - a. Remove the pressure regulator adjustment cap and screw.
 - b. Using a screwdriver, turn the inner adjustment screw clockwise ↻ to increase, or counterclockwise ↺ to decrease, the main burner gas pressure.
 - c. Always replace the cap screw and tighten firmly to ensure proper operation.
4. If the desired outlet gas pressure or gas flow rate cannot be achieved by adjusting the gas control, check the gas control inlet pressure using a manometer at the inlet pressure tap. If the inlet pressure is in the normal range (refer to Table 6 or 7), replace the gas control. Otherwise take the necessary steps to provide proper gas pressure to the gas control.

Step-opening pressure regulator

1. The gas control outlet pressure should match the manifold pressure listed on the appliance nameplate.
2. With the main burner operating, check gas control flow rate using the meter clocking method or check the gas pressure using a manometer connected to the gas control outlet pressure tap. Refer to Fig. 4.
3. If necessary, adjust the pressure regulator to match the appliance rating. Refer to Table 5 or 6 for factory-set nominal outlet pressures and adjustment ranges.
 - a. Remove pressure regulator adjustment cap screw.
 - b. Using a screwdriver, turn the inner adjustment screw clockwise ↻ to increase or counterclockwise ↺ to decrease the main burner gas pressure.
 - c. Always replace the cap screw and tighten firmly to ensure proper operation.
4. If the desired outlet pressure or flow rate cannot be achieved by adjusting the gas control, check the inlet pressure using a manometer at inlet pressure tap or upstream of the gas control. If the inlet pressure is in the normal range (refer to Table 6 or 7), replace the existing gas control. Otherwise, take the necessary steps to provide proper gas pressure to the gas control.

- Carefully check main burner lightoff at the step pressure. Ensure the main burner lights smoothly and without flashback to the orifice and that all ports remain lit. Cycle the main burner several times, allowing at least

30 seconds between cycles for the regulator to resume the step function. Repeat after allowing the main burner to cool. Readjust the full rate outlet pressure if necessary to improve lightoff characteristics.

Table 6. Pressure regulator specification (pressures in inches WC)

Model	Type of gas	Nominal inlet pressure range	Outlet Pressure			
			Nominal factory setting		Setting range	
			Step	Full rate	Step	Full rate
Standard, slow-opening	Natural	5.0–7.0	–	3.5	–	3.0–5.0
	LP	12.0–14.0	–	11.0	–	8.0–12.0
Step-opening	Natural	5.0–7.0	0.9	3.5	–	3.0–5.0
	LP	12.0–14.0	2.2	11.0	–	8.0–12.0

Table 7. Pressure regulator specification (pressures in kPa)

Model	Type of gas	Nominal inlet pressure range	Outlet Pressure			
			Nominal factory setting		Setting range	
			Step	Full rate	Step	Full rate
Standard, slow-opening	Natural	1.2–1.7	–	0.9	–	0.7-1.2
	LP	2.9–3.9	–	2.7	–	2.0-3.0
Step-opening	Natural	1.2–1.7	0.2	0.9	–	0.7-1.2
	LP	2.9–3.9	0.9	2.7	–	2.0-3.0

Check Safety and Shutdown Performance

WARNING

Fire or explosion hazard. Can cause property damage, severe injury or death. Perform the safety shutdown test any time work is done on a gas system.

Read steps 1–7 below before starting and compare to the safety shutdown or safety lockout tests recommended for the intermittent pilot (IP) module. Where they differ, use the procedure recommended for the module.

- Turn gas supply off.
- Set the thermostat or the controller above room temperature to call for heat.
- Watch for spark at the pilot burner either immediately or following prepurge. See IP module specifications.
- If the module has timed ignition, time the length of spark operation. See IP module specifications.
- After the module locks out, open the gas control knob and ensure there is no pilot or main burner gas flow. *With modules that continue to spark until pilot lights or system is shut down manually, the pilot should light when gas control knob is opened.*
- Set the thermostat below room temperature and wait one minute.
- Operate the system through one complete cycle to ensure all controls operate properly.

Regular preventive maintenance is important in applications that place a heavy load on system controls, such as in the commercial cooking and agricultural and manufacturing industries, because:

- In many such applications, particularly commercial cooking, the equipment operates 100,000 to 200,000 cycles per year. Such heavy cycling can wear out the gas control in one to two years.
- Exposure to water, dirt, chemicals and heat can damage the gas control and shut down the control system.

The maintenance program should include regular checkout of the gas control as outlined under “STARTUP AND CHECKOUT” on page 4, and the control system as described in the appliance manufacturer’s literature. Maintenance frequency must be determined individually for each application. Some considerations are:

- Cycling frequency.** Appliances that might cycle 100,000 times annually should be checked monthly.
- Intermittent use.** Appliances that are used seasonally should be checked before shutdown and again before the next use.
- Consequence of unexpected shutdown.** Where the cost of an unexpected shutdown would be high, the system should be checked more often.
- Dusty, wet, or corrosive environment.** Since these environments can cause the gas control to deteriorate more rapidly, the system should be checked more often.

MAINTENANCE

WARNING

Fire or explosion hazard. Can cause property damage, severe injury or death. Improper cleaning or reassembly may cause gas leakage. When cleaning, ensure that the control is reassembled properly and perform the gas leak test.

The gas control should be replaced if:

- It does not perform properly on checkout or troubleshooting.
- It is likely to have operated for more than 200,000 cycles.
- The gas control knob is hard to turn or push down or it fails to pop back up when released.

Service

WARNING

Fire or explosion hazard. Can cause property damage, severe injury, or death. Do not disassemble the gas control; it contains no replaceable components. Attempted disassembly or repair may damage the gas control.

CAUTION

Do not apply a jumper across or short the valve coil terminals. Doing so may burn out the heat anticipator in the thermostat or damage the electronic module.

IMPORTANT

Allow 60 seconds after shutdown before re-energizing the step-opening module to ensure lightoff at steppressure.

IF MAIN BURNER WILL NOT COME ON WITH CALL FOR HEAT

1. Ensure the gas control knob is in the ON position.
2. Adjust the thermostat several degrees above room temperature.
3. Using an AC voltmeter, check for 24V at gas control.
 - If pilot lights, measure across MV/PV and MV.
 - If pilot does not light, measure across MV/PV and PV before safety lockout occurs.
4. If voltage is incorrect or not present, check control circuit for proper operation.
5. If 24V is present, replace the gas control.

INSTRUCTIONS TO THE HOMEOWNER

WARNING

Fire or explosion hazard. Can cause property damage, severe injury, or death.

Follow these warnings exactly:

1. Pilot flame is lit automatically. Do not light the pilot flame manually.
2. Before lighting the pilot burner flame, smell around the appliance for gas. Be sure to smell close to the floor because LP gas is heavier than air.
3. IF YOU SMELL GAS:
 - Turn off the gas supply at the appliance service valve on LP gas systems, turn off gas supply at the gas tank.
 - Do not light any appliances in the house.

Automation and Control Solutions

Honeywell International Inc.
1985 Douglas Drive North
Golden Valley, MN 55422
customer.honeywell.com

Honeywell Limited-Honeywell Limitée
35 Dynamic Drive
Toronto, Ontario M1V 4Z9

- Do not touch electrical switches or use the phone.
 - Leave the building and use a neighbor's phone to call your gas supplier.
 - If you cannot reach your gas supplier, call the fire department.
4. Do not force the gas control knob. Use only your hand to push down or turn the gas control knob. Never use tools. If the gas control knob will not operate by hand, the gas control should be replaced by a qualified service technician. Force or attempted repair may result in a fire or explosion.
 5. The gas control must be replaced in case of any physical damage, tampering, bent terminals, missing or broken parts, stripped threads, or evidence of exposure to heat.

IMPORTANT

Follow the operating instructions provided by the manufacturer of your heating appliance. The information below will be of assistance in a typical gas control application, but the specific controls used and the procedures outlined by the manufacturers of your appliance may differ, requiring special instructions.

STOP! READ THE WARNINGS ABOVE!

The pilot flame is lit automatically. If the appliance does not turn on when the thermostat is set several degrees above the room temperature, follow these instructions.

1. Set the thermostat to its lowest setting to reset the safety control.
2. Disconnect all electric power to the appliance.
3. Remove the gas control access panel.
4. Push in the gas control knob slightly and turn clockwise ↻ to OFF.
5. Wait five minutes to clear out any unburned gas. If you then smell gas, STOP! Follow Step 3 in the Warnings above. If you do not smell gas, continue with the next step.
6. Turn the gas control knob counterclockwise ↶ to PILOT.
7. Turn the gas control knob counterclockwise ↶ to ON.
8. Replace the gas control access panel.
9. Reconnect all electric power to the appliance.
10. Set the thermostat to the desired setting.
11. If the appliance does not turn on, set the gas control knob to OFF and contact a qualified service technician for assistance.

Turning off the Appliance

VACATION SHUTDOWN—Set the thermostat to the desired room temperature while you are away.

COMPLETE SHUTDOWN—Push the gas control knob in slightly and turn clockwise ↻ to OFF. Do not force. Appliance will completely shut off. Follow the lighting procedures above to resume normal operation.