

# INSTRUCTIONS



**Carrier**

A United Technologies Company

Page 1 of 4

Instruction Sheet Number:  
**99TA509591B**

\*XX99TA509591B\* (for RCD use only)

---

Description: ELECTRONIC MULTI-FUNCTION TIMER

Author: Richard Cummings

Date: August 14, 2003

Part Number: HK35AA004, HK35AA005, HK35AA008, HK35AA009

## MULTI-FUNCTION TIMER SUBSTITUTION

Attached are two wiring schematics for the application of the HK35AA008 and HK35AA009 multi-function timers. The first schematic is for replacing an electro-mechanical timer like an HK25AZ070 or HK25AZ080. The main difference is in the wiring to the "M" terminals. It can also be used when replacing the HK35AA004 and HK35AA005 timers, which in this case is no differences.

The second abbreviated wiring schematic is for replacing an electro-mechanical timer like an HK25AZ070 or HK25AZ080 which is used in a single compressor unit like 30HK/HL015-030. The differences are in the wiring to the "M" terminals AND to the unloader relay(UR). In this case, it is recommended to leave the unloader relay disconnected. With normal step control operation the unit will start unloaded since only the first stage should be energized. Only when all three stages are energized will the unit start fully loaded.

Below is a copy of SMB980023:

---

Date:4/21/98 Subject: ELECTRONIC MULTI-FUNCTION Dept. CSS FIELD  
TIMER HK35AA005 & 004 TECH SUPPORT

Number: SMB980023

Author: DAVID A BARKLEY

### MODELS AFFECTED:

HK35AA005(60HZ) and HK35AA004(50HZ)  
38AH044,054,064,074,084,094,104,124,134 Condensing Unit  
48MA016,024,028,030,034,040 Multizone Rooftop  
50ME016,024,028,030,034,040 Multizone Rooftop

### SERIAL NUMBERS:

38AH models – first s/n with new timer (HK35AA009,008) is 1698F37783  
last build s/n with old timer (HK35AA005,004) is 1698F37763  
48MA,50ME models – first s/n with HK35AA009,008 is 1798F38762  
last build s/n with HK35AA005,004 is 1498F34421

Continued on sheet#2

**PURPOSE:**

To provide information regarding a change to the HK35AA004 and HK35AA005 Electronic Multi-Function Timers to correct a “lock-out” situation when applied on above units in some locations where there are momentary power interruptions of less than 50 milliseconds.

**SITUATION:**

Some units, particularly the multi-zone rooftop units and occasionally the 38AH condensing units, have experienced a “lock-out” condition when a momentary power interruption of less than 50 milliseconds has occurred. In this situation, power must be turned off to the timer and reestablished in order to reset the timer. The timer ignores power interruptions of less than 50 milliseconds while a holding relay (particularly on the multi-zone products) de-energizes and the relay contacts open. The timer assumes everything is fine (ignores power interruptions of less than 50 milliseconds), but the compressor is OFF due to the holding relay not being energized.

The timer microprocessor program and hardware on the timer board has been changed to compensate for the momentary power interruption. The connection points and all application wiring is identical to the older version timers. The new timer part numbers are HK35AA009(115 volt) and HK35AA008 (230 volt) replacing the HK35AA005 and HK35AA004, respectively.

**FACTORY ACTION:**

The new timers have been implemented in production starting with serial number 1698F37783 for the 38AH products and 1798F38762 for the 48MA and 50ME multizone products.

**FIELD ACTION:**

If lockouts occur as a result of momentary power interruptions, replace the existing timer with part number HK35AA008 for a 230 volt control circuit (used on 60HZ units) or HK35AA009 for a 115 volt control circuit (used on most 60HZ products). RCD is purging all of its old stock in inventory of the HK35AA004 and HK35AA005 timers to assure only the revised timers are available. Remember: When replacing an older style electro-mechanical timer (i.e., Paragon), the new timer does NOT have a physical motor. Connect one wire to one of the “M” motor terminals (as indicated by the unit wiring diagram) and the other wire to the second “M” terminal. These two “M” terminals have the same electrical potential, but do not create a short circuit since the load for the “A” contacts are internal to the electro-mechanical timers (i.e., “A”, “B”, “C”, and “D” terminals of the HK25AZ080). Refer to the attached typical wiring diagram.

Continued on sheet #3

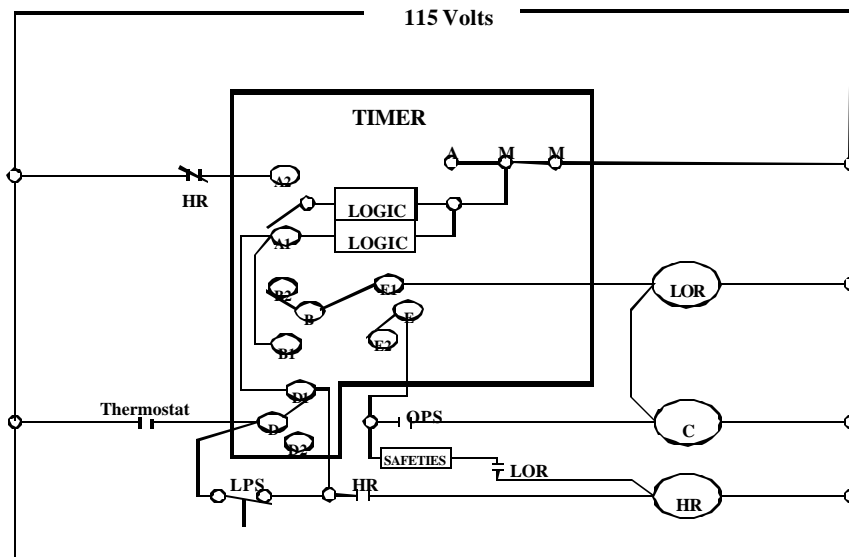
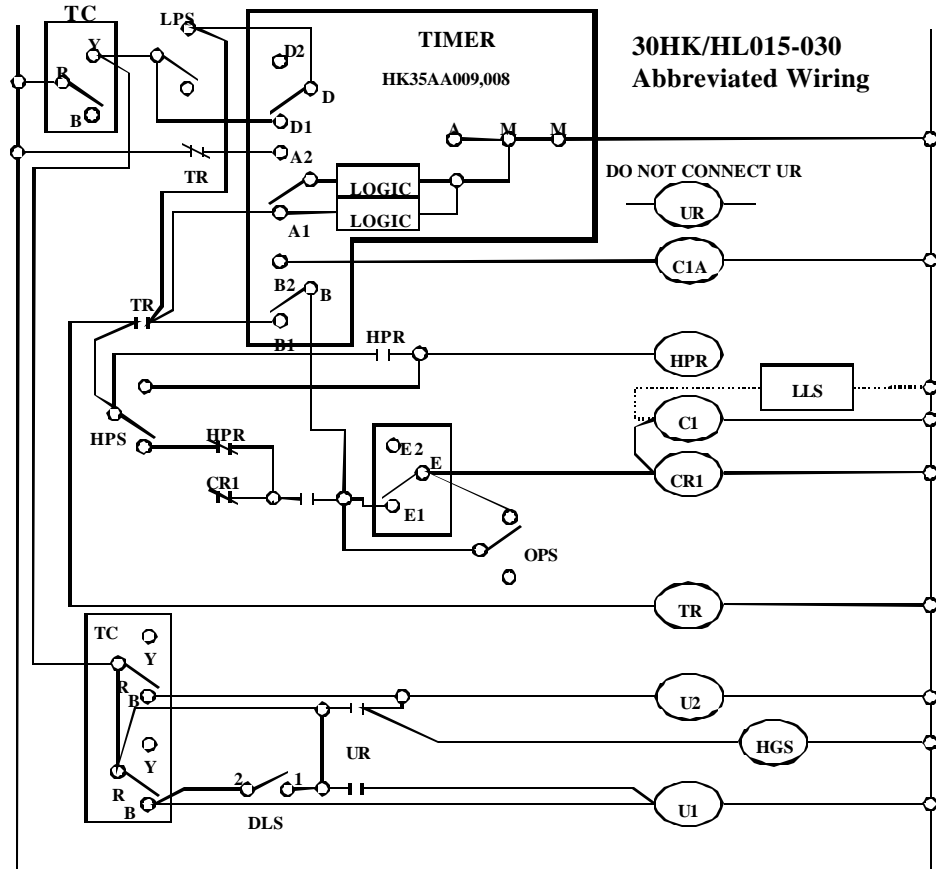

**HK35AA009 Multi Function Timer Typical Wiring**

**LEGEND**

- LPS Low Pressure Switch
- LOR Lockout Relay
- HR Holding Relay
- OPS Oil Pressure Switch
- C Either Compressor Contactor or Pilot Duty Relay Controlling a Compressor Contactor
- Safeties Safeties (For Example an HPS)
- HPS High Pressure Safety Switch

