

# AK-42309-500

## Positive Positioner Pneumatic Relay

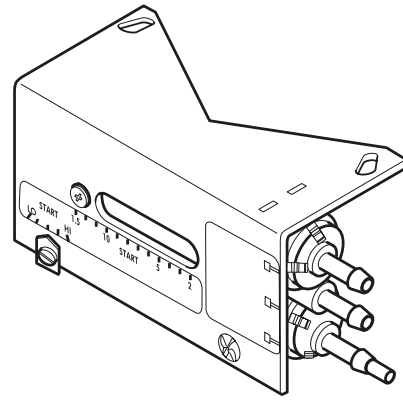

### Application

- The AK-42309-500 Positive Positioner Pneumatic Relay is used to accurately position an actuator with respect to signal pressure from the controller. It can also be used to change the effective spring range of an actuator and increase the capacity of a controller.
- The AK-42309-500 Positive Positioner Pneumatic Relay is compatible with MK-2690-0-0-1, MK269000-2, MK-3XXX, MK-44XX, MK46X1XXX0-2, MK48XX, MK-66XX, MK-68XX, MK69XX, MK7XXX, MK-88XX, and MK-89XX Series actuators. The AK42309-500 cannot be used with the following actuators: M556, M573, M574, M693, MK2690-0-0-0, MK-4600-0-0-0, MK-4600-0-0-1, and MK-12000 Series actuators.

### Features

- Force-balance relay-type position sensing mechanism
- Main-air and exhaust connections at actuator location speeds actuator response
- Large air capacity
- Adjustable start-point and span

### Applicable Literature

- Environmental Controls Reference Manual, F-21683
- EN-123 Air Quality Requirements for Pneumatic HVAC Control Systems, F-22516
- Pneumatic Products Catalog, F-27383
- Material Safety Data Sheet, MSDS-7

### Specifications

Action	Direct (increase in output pressure to actuator with an increase in pilot pressure from controller)
Pilot input	0 to main air pressure, psig
Output	0 to main air pressure, psig
Construction Materials	
Housing	Polysulfone
Diaphragm	Neoprene
Start Point	Adjustable 1...12 psig (7...83 kPa)
Span	Adjustable 2...13 psig (14...90 kPa); factory set at 5 psig.
Supply Air	Clean, oil free, dry air required (refer to EN-123, F-22516)

Maximum Pressure	30 psig (207 kPa)
Nominal Supply Pressure	15...20 psig (103 to 138 kPa)
Environmental	
Ambient Temperature Limits	
Shipping	-40...160 °F (-40...71 °C).
Operating	32...140 °F (0...60 °C).
Humidity	5...95% R.H., non-condensing
Enclosure Rating	NEMA Type 1
Air Connection Code	See Figure 1
Air Connections	"M" and "B," Barbed for 1/4 in. (6 mm) O.D. plastic tubing;"P;" Dual-contoured for 1/4 in. (6 mm) O.D. and 5/32 in. 4 mm) O.D. tubing
Air Consumption for Sizing	
Air Compressor	0.011 scfm (5.2 ml/s) at 20 psig (138 kPa) supply
Air Capacity for Sizing Air Mains	20 scim (5.5ml/s)
Flow Capacity	860 scim (235 ml/s) at 20 psig (138 kPa) supply
Mounting Linkage	All necessary linkage provided to mount the AK-42309-500 Positive Positioner to MK-2690-0-0-1, MK-2690-0-0-2, MK-3XXX, MK-44XX, MK-46X1-XXX-0-2, MK-48XX, MK66XX, MK-68XX, MK-69XX, MK-7XXX, MK-88XX, and MK-89XX series actuators.
Dimensions	2½ H x 4½ W x 3 D in. (64 x 114 x 76 mm). See Figure 12
Accessories	
TOOL-95-1	Pneumatic calibration tool kit

## Typical Applications (piping diagram)

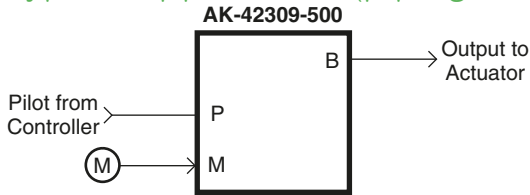

Figure 1. Piping Connections.

## Installation

### Inspection

Inspect the package for damage. If damaged, notify the appropriate carrier immediately. If undamaged, open the package and inspect the device for obvious damage. Return damaged products.

### Requirements

- Piping diagrams
- Linkage kit (provided with the AK-42309-500 Positive Positioner)
- Tools (not provided):
  - 1/4" (6 mm) maximum single blade screwdriver for start point lock and span adjustment lock
  - Appropriate socket wrenches for mounting bracket to the actuator.
  - Needle nose pliers for bending feedback spring
  - Tubings and fittings (not provided)
- Training: Installer must be a qualified, experienced technician.

## Precautions

- Make all connections in accordance with the piping diagram.
- Do not exceed the ratings of the device(s).

## Main Air Supply

Particles in the main air supply larger than 0.03 microns will adversely affect the reliability and life of the relay unit. A refrigerated air dryer, particulate filter, and coalescing filter will provide a quality air supply (refer to EN-123, F-22516).

Oil, dirt, and water in the main air supply will cause unwarranted damage to the positive positioner and void the warranty.

Compressor oil must be mineral base. Synthetic base oils will destroy pneumatic controls and void the warranty.

## Location

Do not locate unit in areas subject to excessive vibration or corrosive atmospheres.

## Mounting

### Suggested Mounting Sequence

- MK-2690-0-0-1, MK-2690-0-0-2, MK-46X1-XXX-0-2, and MK-48XX actuators can be mounted to the valve before the AK-42309-500 Positive Positioner is mounted to the actuator.
- The MK-66XX, MK-68XX, MK-69XX, MK-88XX, and MK-89XX series actuators can be mounted to the valve before the AK-42309-500 Positive Positioner is mounted to the actuator, but the valve linkage must be disconnected in order to install the feedback arm and the indication disc.
- When mounting the AK-42309-500 Positive Positioner to the MK-3XXX and MK-7XXX series actuators, mount the positive positioner to the actuator and install the positive positioner's feedback arm on the actuator before mounting the actuator to the damper.

## Mounting the AK-42309-500 Positive Positioner to Actuators

### MK-2690-0-0-1 and MK-2690-0-0-2 (Figure 2)

1. Mount the AK-42309-500 to the MK-2690-0-0-(1, 2) actuator as follows:
2. Line up positive positioner mounting bracket holes with the mounting holes on the actuator cover (Figure 2).
3. Assemble with the two (2) short mounting screws and tighten.
4. Select the appropriate spring and feedback arm from the linkage kit (Table 1). Balance of parts may be discarded or retained for spares.

### MK-3XXX, MK-44XX, MK-46X1-XXX-0-2, and MK-48XX (Figure 3, Figure 4, and Figure 6)

Mount the AK-42309-500 to the MK-3XXX, MK-44XX, MK-46X1-XXX-0-2, and MK-48XX actuators as follows:

1. Remove referenced cover screws and discard.
 

Note: All older MK-3XXX actuators which do not have flat pads around mounting screw locations require spacers from the linkage kit provided with the AK-42309-500 Positive Positioner.
2. Line up positive positioner mounting bracket holes with actuator cover screw holes shown in Figure 3, Figure 4, and Figure 6.
3. Reassemble with specified screws (included with the AK-42309-500) through positive positioner mounting bracket holes and tighten.
4. Select the appropriate spring and feedback arm from the linkage kit (Table 1). Balance of parts may be discarded or retained for spares.

### MK66XX, MK-68XX, MK-69XX, MK-7XXX, MK-88XX, and MK-89XX (Figure 7, Figure 8, and Figure 9)

Mount the AK-42309-500 to the MK-66XX, MK-68XX, MK-69XX, MK-7XXX, MK88XX, and MK-89XX series actuators as follows:

1. Remove actuator cover screws and set aside.
2. Line up positive positioner mounting bracket holes with actuator cover screw holes. (See Figure 7, Figure 8, or Figure 9.)
3. Reassemble with actuator cover screws through positive positioner mounting bracket holes and tighten.
4. Select the appropriate spring and feedback arm from the linkage kit provided with the AK-42309-500 Positive Positioner (Table 1). Balance of parts from the linkage kit may be discarded or retained for spares.

### Installing the Feedback Arm

#### MK-2690-0-0-1, MK-2690-0-0-2, MK-44XX, MK-46X1-XXX-0-2, and MK-48XX (Figure 2, Figure 5, and Figure 6)

Install the feedback arm on the AK-42309-500 Positive Positioner as follows:

1. Consult Table 1 to select appropriate feedback arm.
2. Push the feedback arm firmly into the hole provided in the diaphragm piston with the hook rotated 45° to 90° from the final position.
3. Lock the arm into the diaphragm piston by twisting the arm into position with a downward force.

#### MK-3XXX, MK-66XX, MK-68XX, MK-69XX, MK-7XXX, MK-88XX, and MK-89XX (Figure 3, Figure 7, Figure 8, and Figure 9)

To install, secure the feedback arm to the valve stem or actuator output shaft.

### Installing the Feedback Spring

1. Choose the appropriate feedback spring from the linkage kit provided with the AK42309500 Positive Positioner.
2. Move the AK-42309-500 Start Point lever (Figure 10) to the "Lo" position (required to position the feedback lever).
3. Position the span adjustment slider to align the spring hook mounting hole to the scale below (required to set the operating span of the actuator).

4. Line up the feedback arm and span adjustment slider.
5. Insert hooked end of feedback spring into the back of the hole on the span adjustment slider ( Figure 10).
6. Cut off feedback spring 1/2 to 3/4" (13 to 19 mm) beyond the end of the feedback arm.
7. Form bend, approximately 1/4" (6 mm) from the free end of the feedback spring to allow approximately 1/32 to 1/16" (0.8 to 1.6 mm) tension at the feedback arm.

Notice: Do not put a sharp bend in the feedback spring. More than 1/16" (1.6 mm) of tension on the spring may prevent adjustment to low start points.

8. Connect the bent end of the feedback spring to the feedback arm.

**Table 1. Actuator and Valve Compatibility with AK-42309-500 Positive Positioner Feedback Arm.**

**Feedback Spring Dimensions**

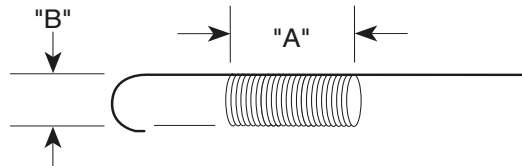

Actuator	Where Used, valve size in inches (metric equivalent in mm)	Factory Set Actuator Stroke in. (mm)	Dimension "A" in. (mm)	Dimension "B" in. (mm)	Feedback Arm	Feedback Arm Mounting Hole Diameter in. (mm)
MK-2690-0-0-1 and MK-2690-0-0-2	VB-7XXX and VB9XXX, 1/2 to 1 1/4 (15 to 50)	7/16 (11)	11/16 (17)	5/16 (8)		N.A.
MK-3XXX	Dampers	3 1/2 (89) Adjustable 2 to 4 (51 to 102)	For actuator strokes less than 3 (76), 1-1/8 (29). For strokes 3 to 4 <sup>b</sup> (76 to 102), 15/8 (41).	11/16 (17)		21/64 (8)
MK-44XX	Dampers	1 <sup>c</sup> (25)	1-3/32 (28)	7/16 (11)		N.A.
MK-46X1-XXX-0-2 <sup>a</sup>	VB-7XXX, 1/2 to 2 (15 to 50) and VB-9XXX, 1/2 to 1 1/4 (15 to 32)	7/16 (11)	11/16 (17)	5/16 (8)		N.A.
MK-48XX <sup>d</sup>	VB-9XXX, 1 1/2 to 2 (40 to 50)	29/32 (23)	1-3/32 (28)	7/16 (11)		N.A.
MK-66XX	VB-7XXX, 1/2 to 2 (15 to 50)	7/16 (11)	11/16 (17)	5/16 (8)		N.A.
MK-68XX	VB-9XXX, 1 1/2 to 4 (40 to 80)	29/32 (23)	1-3/32 (28)	7/16 (11)		N.A.
MK-69XX	VB-9XXX, 5 and 6 (none)	1-27/32 (46)	1-1/8 (29)	11/16 (17)		N.A.
MK-7XXX	Dampers	4 1/2 (114) Adjustable 4 to 5 (102 to 127)	2 1/4 (57) <sup>b</sup>	11/16 (17)		33/64 (13)
MK-88XX	VB-9XXX, 2 1/2 to 4 (65 to 80)	29/32 (23)	1-3/32 (28)	7/16 (11)		N.A.
MK-89XX	VB-9XXX, 5 and 6 (none)	1-27/32 (46)	1-1/8 (29)	11/16 (17)		N.A.

a - AK-42309-500 cannot be mounted on MK-2690-0-0-0, MK-4600-0-0-(0,1), or MK-12000 series actuators.

b - See page 10 for Span Slider Setting Instructions.

c - Linkage is factory set at 2" (51mm). Linkage is adjustable from 1/2 to 3" (13 to 76mm).

d - The MK-48XX actuator series is offered for retrofit on obsolete VB-9XXX valves. This actuator cannot be used with VB-7XXX valves.

## Piping

Before installing tubing, see Figure 2 through Figure 9 for proper alignment and refer to the piping diagram and an example of typical piping (Figure 1 and Figure 11). Install tubing as follows:

1. Install 1/8 MNPT x 1/4" (3.2 x 6mm) barb fitting into air connection on actuator.
2. Remove referenced cover screws and discard.
3. Connect 1/4" O.D. (6mm) plastic tubing between fitting in actuator and "B" port on the positive positioner.
4. Connect main air supply to "M" port.
5. Connect controller output (variable air signal) to "P" port.

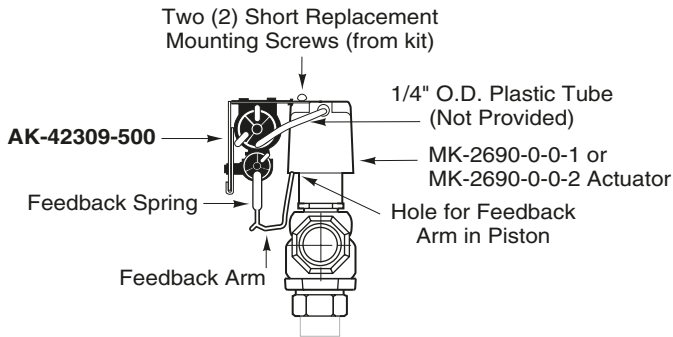

Figure 2. MK-2690-0-0-1 and MK-2690-0-0-2.

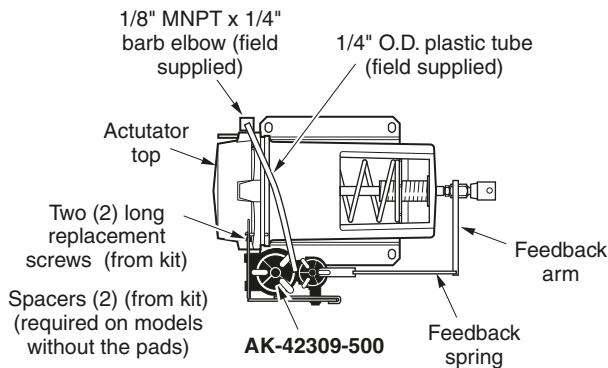

Figure 3. MK-3XXX

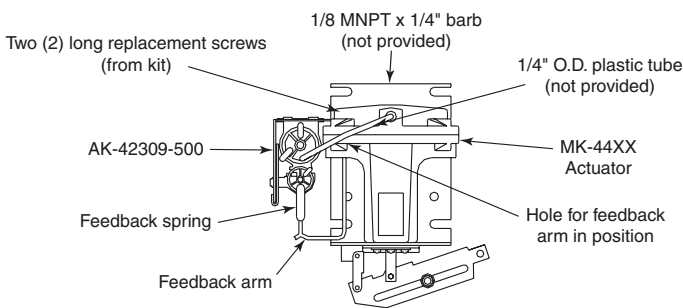

Figure 4. MK-44XX.

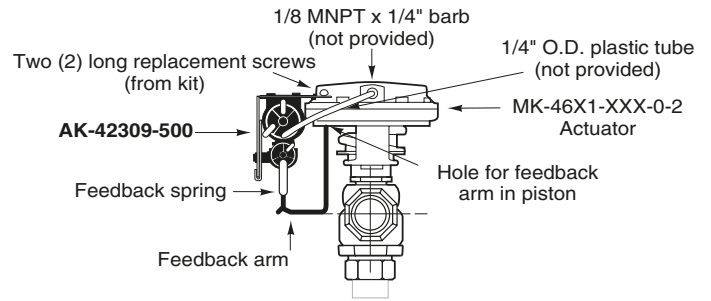

Figure 5. MK-46X1-XXX-0-2 Series.

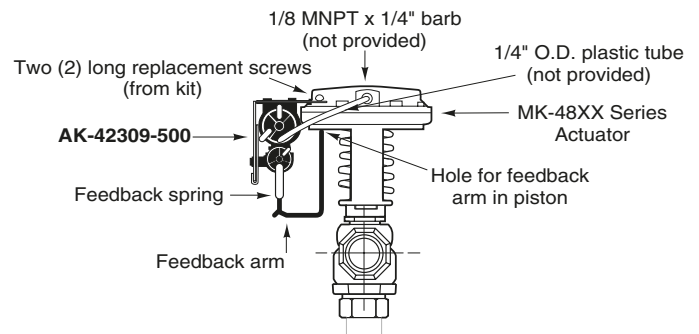

Figure 6. MK-48XX Series.

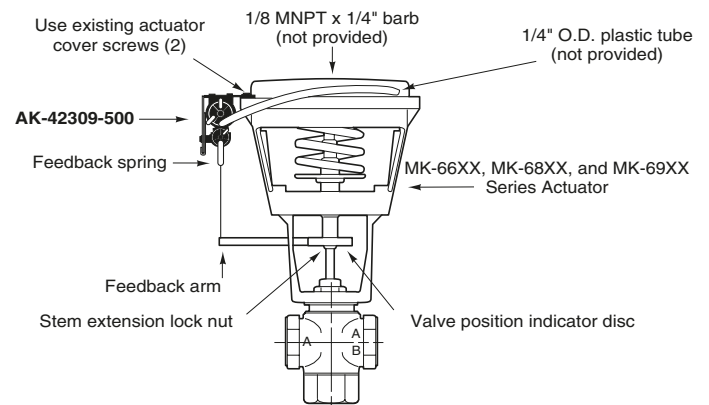

Figure 7. MK-66XX, MK-68XX, and MK-69XX Series

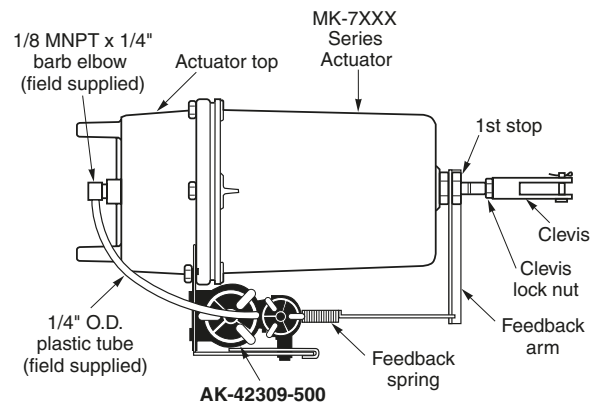

Figure 8. MK-7XXX Series.

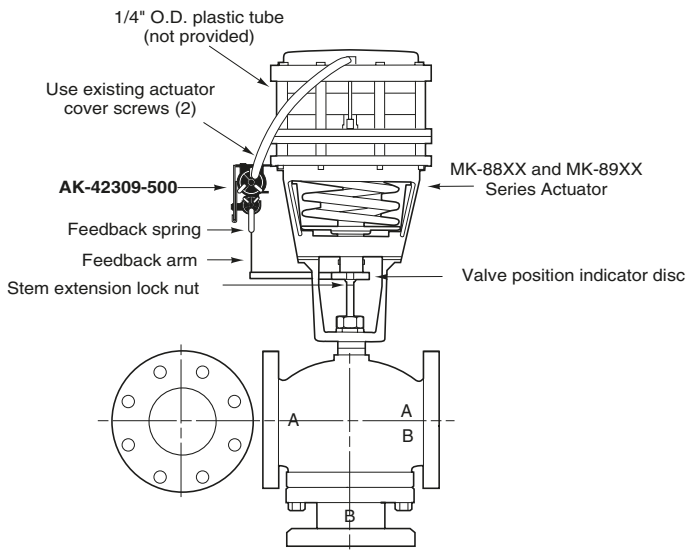

Figure 9. MK-88XX and MK-89XX Series.

## Setup

### Start Point ( Figure 10 and Figure 11)

Start point is the pressure at which the actuator shaft just begins to extend. Start point must be adjusted after any span slider setting. Adjust the start point as follows:

1. Connect main air supply to "M" port and a variable air signal to "P" port.
2. Adjust variable air signal on "P" port to desired start point pressure.
3. Loosen start point lever lock screw.
4. Adjust lever until actuator just starts to extend.
5. Tighten lock screw.
6. Remove variable air signal from "P" port and connect to controller output.

### Span Slider Setting ( Figure 10 and Figure 11)

Span is the pilot pressure change required to produce a full actuator stroke. The span can be changed by repositioning the span adjustment slider.

**MK-2690-0-0-1, MK-2690-0-0-2, MK-44XX, MK-46X1-XXX-0-2, MK-48XX, MK-66XX, MK-68XX, MK69XX, MK-88XX, MK-89XX**

1. Determine the span required.
2. Set the span adjustment slider.

### MK-3XXX and MK-7XXX

The MK-3XXX and MK-7XXX series actuators have adjustable strokes. The adjustable stroke requires the span adjustment slider setting to be calculated for the AK42309-500 Positive Positioner.

1. Determine the required actuator stroke.
2. Determine the span required.
3. Calculate the span adjustment slider position (SASP) as follows:
  - MK-3XXX with stroke less than 3" (76 mm)

$$\frac{Span \times 2}{ActuatorStroke} = SASP$$

- MK-3XXX with stroke 3 to 4" (76 to 102 mm)

$$\frac{Span \times 3}{ActuatorStroke} = SASP$$

- MK-7XXX

$$\frac{Span \times 4}{ActuatorStroke} = SASP$$

Example: MK-3XXX

Span = 8 psi (55 kPa)

Actuator Stroke = 3½" (89 mm)

$$SASP = \frac{8 \times 3}{3.5} = 6.9$$

4. Set span adjustment slider to the calculated position.

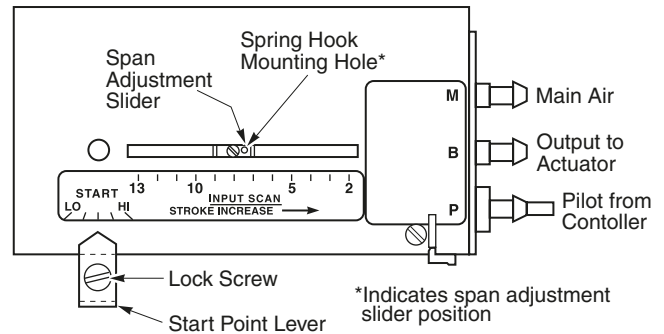

Figure 10. AK-42309-500 Adjustments.

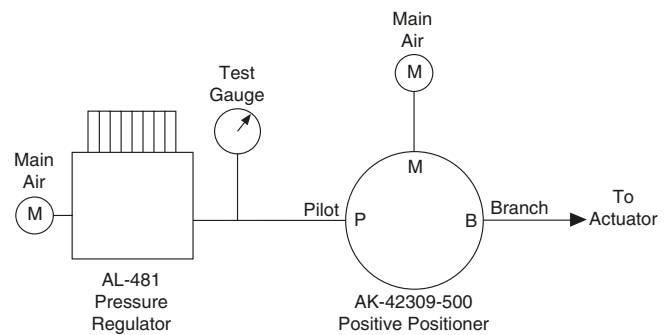

Figure 11. Typical Adjustment Piping.

## Maintenance

Regular maintenance of the total system is recommended to assure sustained optimum performance.

## Field Repair

None. Replace an inoperative positive positioner with a functional unit.

## Dimensional Data

Reassemble with specified screws (included with the AK-42309-500) through positive positioner mounting bracket holes and tighten.

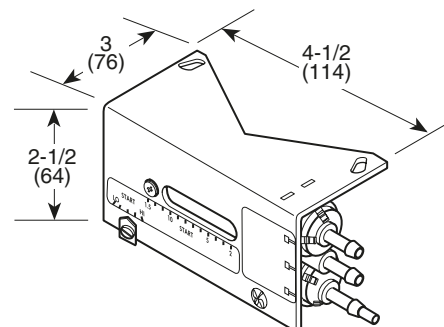

Figure 12. AK-42309-500 Dimensions

