



24 VAC Direct Spark Gas Ignition Control

Quick Reference Guide

The Direct Spark Gas Ignition control module is designed for direct burner ignition and supervision. It can be used in new applications or replaces many popular flame rectification type of direct spark (DSI) modules, including those manufactured by Honeywell, Robertshaw, ICM, Fenwal, and Johnson Controls.

The following is an overview of the control, and is intended to only be used by Certified Service Technicians.

Application

- Gas Furnaces
- Boilers
- Water Heaters
- Commercial Cooking

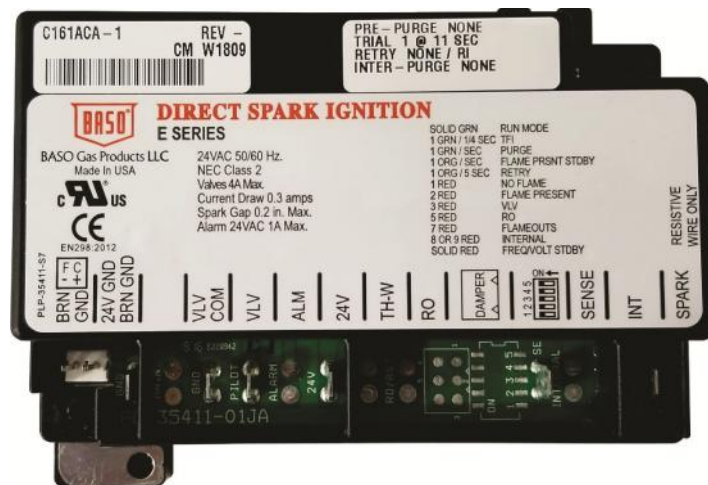

Features

- 24 VAC microprocessor based DSI control
- System diagnostics
- Flame sensing (Local/Internal or Remote/External)
- Full time flame sensing
- Flame sense test pins
- 4 mounting hole positions, 2 that match Honeywell and Fenwal
- Built-in burner ground
- Voltage/Frequency monitoring

Specifications

Input Voltage	Control: 24 VAC(18-30 VAC) 50/60 Hz
Input Current	0.3 A nominal + valves
Gas Valve Contact Rating	4 A Main @ 24 VAC
Alarm Output	2 A @ 24 VAC
Operating Temperature	-40 to 176°F (-40 to 80°C)
Flame Detection Means	Flame Rectification
Flame Detection Type	Local/Internal or Remote/External
Minimum Flame Current	0.07 microamperes
Flame Failure Response Time	1.0 second maximum
Ignition Source	High voltage spark, capacitive discharge
Maximum spark Gap	0.2 in. (5.1 mm)
High Voltage Cable	48 in. (1219mm) max., rated 15kV min. (Resistive recommended)
Flame Sense Cable	48 in. (1219mm) max. (Shielded recommended)
Spark	30 sparks/second
Humidity	0% to 95% RH (non-condensing)
Gas Types	Natural, LP, or Manufactured
Trials Before 100% Shutoff *	Preset 1 thru 9 trials
Trial for Ignition Time *	Preset 4, 8, 11, 21, or 30 seconds
Pre-Purge Time *	Preset 0, 4, 10, 15, or 30 seconds
Inter-Purge Time *	Preset 0, 10, 15, 30, 60, 90, 240, or 300 seconds
Retry Delay Period *,**	Preset 0, 5*, or 60* minutes
Lockout Recovery	Power cycle/Thermostat cycle

*For Custom timings, contact BASO Gas Products.

**Retry is not available in CE ignitions.

Agency Certifications



UL 60370-1, UL 60730-2-5

File: M2926 Software conforms to UL60730 Requirement Component Recognized System (US & Canada)



EN298:2012

File: 657989

Wiring

Table 1: Typical Wiring Connections

Label	Term. Type	Description
FC - +	2 pin	Flame Current test pins for measuring microamps in μ Amp DC
BRN GND	Mounting Tab (Lower Left)	Burner Ground connection*
24V GND BRN GND	1/4" male QC	Common connection
VLV COM	1/4" male QC	Gas Valve common terminal
VLV	1/4" male QC	Valve connection
ALM	1/4" male QC (Optional)	Alarm signal connection
24V	1/4" male QC	24V Power connection
TH-W	1/4" male QC (Optional)	Thermostat "Call to Heat" signal connection
R/O	1/4" male QC (Optional)	Rollout Switch connection
SENSE	1/4" male QC (Optional)	For dual rod (remote/external) flame sensing, connect the flame sense wire from burner/ignitier to this terminal
INT	1/4" male QC (Optional)	For single rod (local/internal) sensing, there will be no connection
SPARK	1/4" male QC	High voltage sparking electrode

* If the existing ignition has an additional burner ground wire with a 1/4" Quick Connect (QC) terminal, it can be connected EITHER to the 24V GND terminal using a double-spaded terminal OR to the BRN GND mounting tab with a screw. For a proper burner ground connection, the 1/4" QC needs to be cut off and replaced with a #8 to #10 Ring Lug connector and secured to the BRN GND mounting tab with a screw.

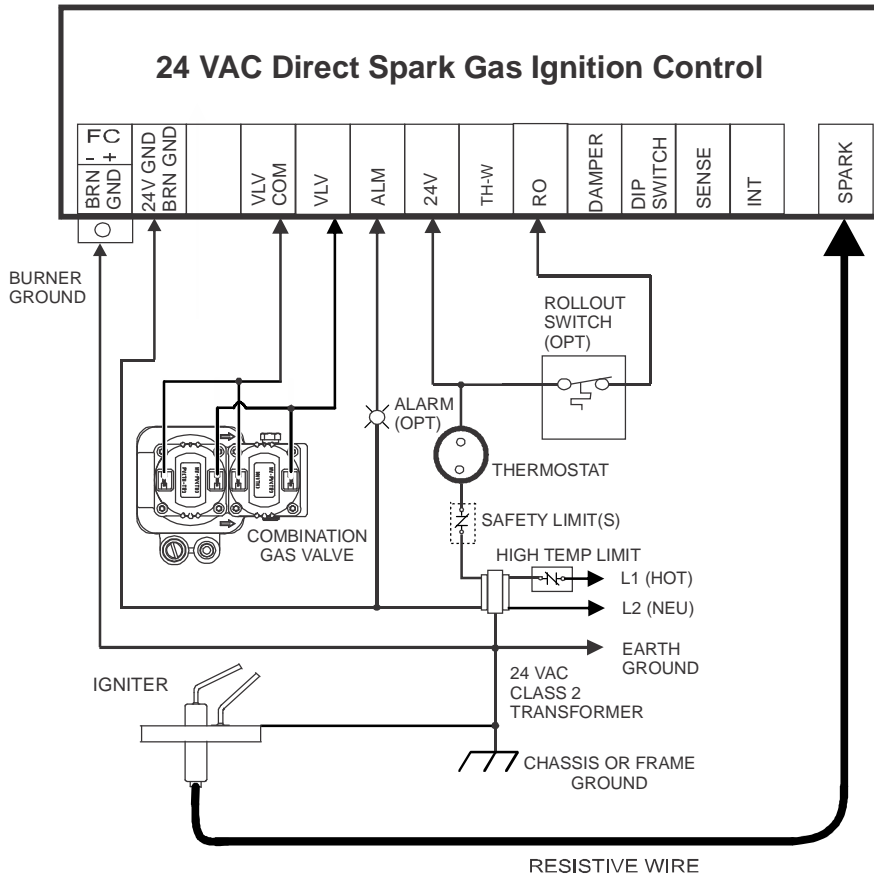

Figure 1: Wiring for 1 Rod Flame Sense used for Local (Internal) Sense

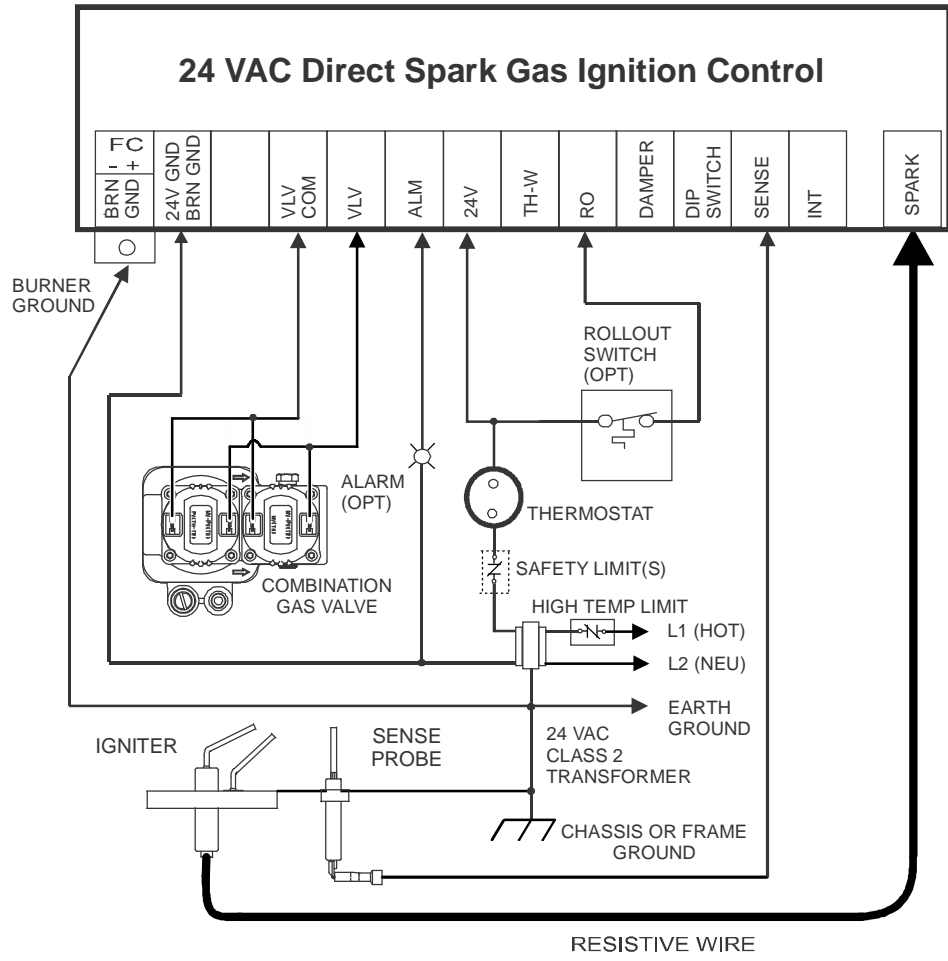

Figure 2: Wiring for 2 Rod Flame Sense used for Remote (External) Sense

Warning: Do not install the control in areas that can be exposed to dripping water, steam cleaning, heavy dust, grease, or corrosive chemicals. If the controls can be subjected to this type of environment, use a NEMA 4 rated enclosure to protect the ignition control module. If not properly protected from the above environment, the control may prematurely fail or malfunction. Excessive high temperatures can damage the ignition control and cause it to malfunction. Make sure the ambient temperature around the ignition does not exceed the rated temperature for the control.

LED Status and Troubleshooting

The ignition control has a multi-colored (GREEN, ORANGE, and RED) LED which will flash different colors and codes to show status of the ignition and will help troubleshoot the control.

Table 2: Green LED Indications of Normal Operation

Flash	Indication
On 1/2 sec, Off 4-1/2 sec	Waiting for "Call for Heat"
On 1/2 sec, Off 1/2 sec	Pre-purge, Inter-purge, Post-purge
On 1/2 sec, Off 1/2 sec	Trial for Ignition (TFI)
On Solid	RUN (Flame, Main valve on)

Table 3: Orange LED Indications

Flash	Indication	Error Type
On 1/2 sec, Off 4-1/2 sec	Retry	Standby
On 1/2 sec, Off 1/2 sec	Flame Present	Standby
On 1/2 sec, Off 1/2 sec	Pressure Present	Standby

Table 4: Red LED Indications of Error Codes (100% Lockout)

Flash	Indication	Error Type
1 flash	No flame in trial time	100% Lockout
2 flashes	Flame sense stuck	100% Lockout
3 flashes	Valve relay circuit	100% Lockout
4 flashes	Inducer (Blower) relay circuit	100% Lockout
5 flashes	Rollout error	100% Lockout
6 flashes	Pressure switch	100% Lockout
7 flashes	Repetitive flame loss	100% Lockout
8 or 9 flashes	Internal control	100% Lockout
Solid On	Line voltage/Frequency	Standby

Note: There is a one-second pause after each flash code.

Troubleshooting Guide

1. No power up
 - Faulty 24 VAC wiring
 - Thermostat or transformer
 - Faulty control
 - Safety limits
2. Control LED is blinking RED
 - Determine error code, refer to error codes (Table 4), also refer to the troubleshooting flow chart in the installation instructions
3. No spark during Trial for Ignition (TFI) time
 - Faulty spark electrode wiring
 - Spark gap too wide
 - Faulty control
4. Burner does not light during trial for ignition time
 - Faulty valve wiring
 - Bad Gas Valve
 - Faulty Control
5. Burner lights but gas valve turns off after TFI
 - Weak flame, flame not in contact with the spark electrode of flame sensor. Check that flame sensor tip is in the flame. For proper sensing, the rod tip must be $\frac{3}{8}$ " (10mm) to $\frac{1}{2}$ " (13mm) in the flame. See figure 3.
 - Dirty or corroded flame sensor
 - Faulty flame sensor wiring
 - Poor burner ground

Note: For more information on BASO ignitions and other products, plus complete installation instructions, please visit us at www.baso.com.

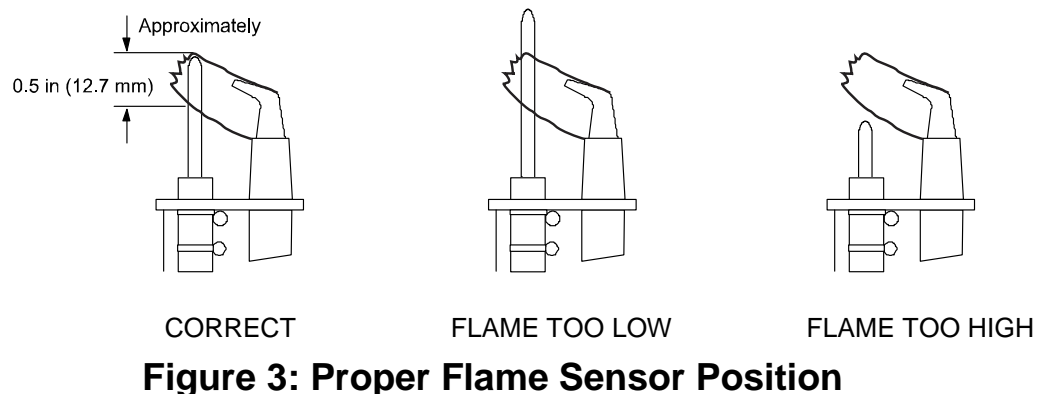

Flame Current Measurement

Flame current of the device can be measured using a standard microammeter by simply touching the meter leads to the 2 PIN labeled FC, as shown in Figure 4.

- Flame current must be measured with flame lit and main gas flowing
- Set meter to DC μ Amp scale.
- Make sure meter leads are positioned correctly [+/-].
- Typical Flame Sense Current of 0.4 to 1.0 μ Amp DC.

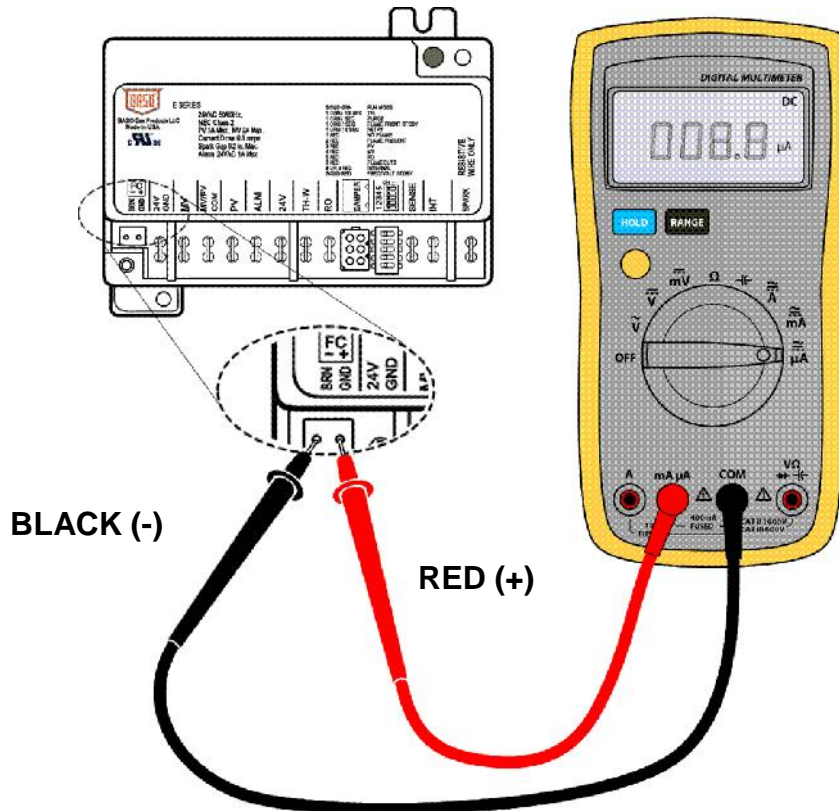

Figure 4: Microammeter Connection

Important: Preventative maintenance programs are an important part of maintaining optimum and safe function of you BASO Products. For more maintenance information, refer to the "Setup and Adjustments" section of the complete installation instructions. Any attempt to repair this assembly voids the manufacturer's 2 year warranty. For a replacement control, contact the original equipment manufacturer or nearest BASO Gas Products distributor.

450 East Horseshoe Road
PO Box 170
Watertown, WI 53094
1-877-227-6427 (1-877-BASOGAS)

www.baso.com
Published in U.S.A.