



THE HIGH PERFORMANCE COMPANY

Series 70

Servo NXT - Modulating Controller

Installation, Operation and Maintenance Manual

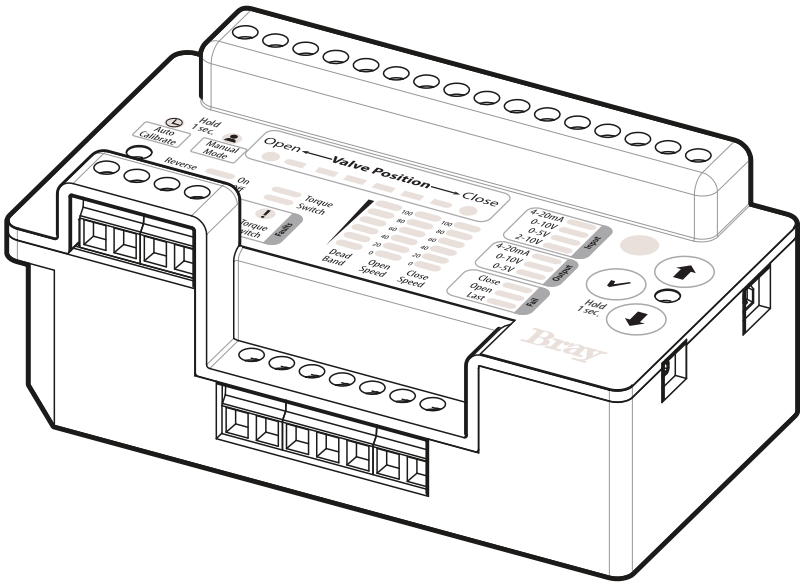



FOR MORE INFORMATION ON THIS PRODUCT AND OTHER BRAY PRODUCTS
PLEASE VISIT OUR WEBSITE – www.bray.com

Table of Contents

1. Definition of Terms	2
2. Safety	2
2.1 Hazard-Free Use	2
2.2 Qualified Personnel.	2
3. Description of Operation	3
4. User Interface	3
4.1 Product Settings	3
4.1.1 Changing Settings.	4
4.1.2 Description of Settings.	4
4.1.2.1 Input Signal Type	4
4.1.2.2 Output Signal Type	5
4.1.2.3 Failure Position	5
4.1.2.4 Close Speed Control	5
4.1.2.5 Open Speed Control	5
4.1.2.6 Dead Band Control	5
4.1.2.7 Torque Switch Detection	6
4.1.2.8 Reverse Acting Mode	6
4.1.3 Motor Stall Detection	6
4.2 Operating Modes	7
4.2.1 Remote Mode	7
4.2.2 Local Mode	7
4.2.3 Manual Mode	7
4.2.4 Autocalibration Mode	7
4.3 Status Indication	7
4.3.1 Valve Position	7
4.3.2 Fault Status	8
4.3.3 Bray Logo	8
5. Hardware Description	9
5.1 Terminal Connections.	9
5.1.1 Power	9
5.1.2 Heater	9
5.1.3 Motor	9
5.1.4 Input Signal	9
5.1.5 Output Signal	9
5.1.6 FB Pot	10
5.1.7 Control Box	10
5.1.8 Hand Wheel	10
5.1.9 Torque Switch	10
5.1.10 Limit Switch	10
6. Quick Start Guide	11
7. Troubleshooting Guide	12

1. Definition of Terms

**READ AND FOLLOW THESE INSTRUCTIONS
SAVE THESE INSTRUCTIONS**

	WARNING	indicates a potentially hazardous situation which, if not avoided, could result in death or serious injury.
	CAUTION	indicates a potentially hazardous situation which, if not avoided, may result in minor or moderate injury.
	NOTICE	used without the safety alert symbol indicates a potential situation which, if not avoided, may result in an undesirable result or state, including property damage.

2. Safety

2.1 Hazard-Free Use

This device left the factory in proper condition to be safely installed and operated in a hazard-free manner. The notes and warnings in this document must be observed by the user to ensure hazard-free operation of this device.

All necessary precautions need to be taken to prevent damage due to rough handling, impact, or improper storage. Do not use abrasive compounds to clean the device, or scrape its surfaces with any objects.

Configuration and setup procedures for this device are described in this manual. Proper configuration and setup are required for the safe operation of this device.

The control system in which this device is installed must have proper safeguards to prevent injury to personnel, or damage to equipment, should a failure of system components occur.

	WARNING
Equipment controlled by the device can generate large mechanical forces during normal operation.	

2.2 Qualified Personnel

	WARNING
The device must only be installed, commissioned, operated and repaired by qualified personnel.	
Installation, commissioning, operation and maintenance of the device must be performed under strict observation of all applicable codes, standards and safety regulations..	

As per this document, a qualified person is one who is trained in:

- The operation and maintenance of electric equipment and systems in accordance with established safety practices.
- Procedures to energize, de-energize, ground, tag and lock electrical circuits and equipment in accordance with established safety practices.
- The proper use and care of personal protective equipment (PPE) in accordance with established safety practices.
- First aid.

3. Description of Operation

The Bray Series 70 Servo NXT provides complete modulating control and monitoring of the Bray Series 70 Electric Actuator. The basic function of the Servo NXT is to position the S70 Actuator in response to a command signal from a process controller. The process controller contains a desired process set point entered by the user, and continually monitors the process variable (such as flow rate, tank level, etc.) through some type of sensor. Varying the command signal to the Servo NXT will cause the actuator to change position, which will move the associated control valve to modify the process variable. The process controller continually calculates and transmits the appropriate command signal to the Servo NXT to maintain the process at the desired set point.

The command signal to the Servo NXT can be various DC voltage ranges (0-5V, 0-10V, 2-10V) or a 4-20mA current source. The Servo NXT simultaneously provides a feedback output signal, representing the current actuator position. The retransmission output signal reported by the Servo NXT can also be various DC voltage ranges (0-5V, 0-10V) or a 4-20mA current source. These settings along with specific operating modes are enabled by a simple-to-use configuration menu.

4. User Interface

The Servo NXT features a rich, LED-based menu that displays both configurable settings and operational status. Indicators are grouped together based on function, shown by their respective label(s). Without

any user interaction, the Servo NXT will display the factory default product settings, in addition to mode of operation, valve position, and fault status.

4.1 Product Settings

The product settings determine how the Servo NXT will respond to commands from the process controller. These must be defined and verified before operation begins. The settings that can be adjusted on the Servo NXT are, in clockwise order:

- "Input" – Input Command
- "Output" – Output Command
- "Fail" – Failure Position
- "Close Speed" – Close Speed Control
- "Open Speed" – Open Speed Control
- "Dead Band" – Dead Band Control
- "Torque Switch" – Torque Switch Detection
- "Reverse Acting" – Reverse Acting Mode

All units ship with default settings from the factory.

Feature	Setting
Input Command	4-20mA
Output Command	4-20mA
Failure Position	Last
Open Speed Control	100%
Close Speed Control	100%
Dead Band Control	3%
Torque Switch Detection	Off
Reverse Acting Mode	Off

Figure 1: Servo NXT default settings

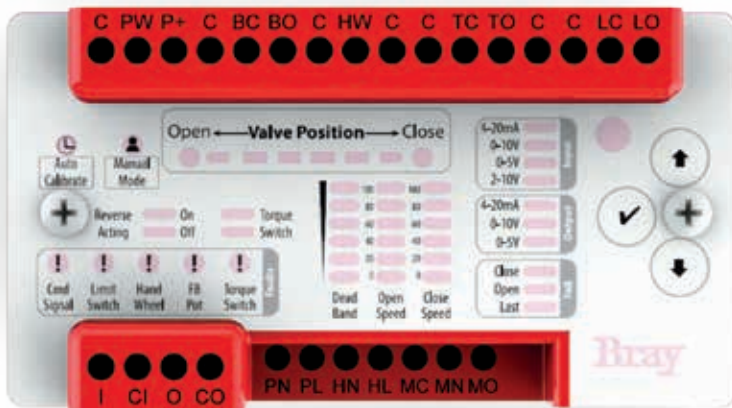

Figure 2: Servo NXT Menu

4.1.1 Changing Settings

Settings can be changed locally by utilizing the keypad on the Servo NXT. The keypad is located on the right side of the unit, and the keys are labelled based on the operation performed.

- Up arrow - Cycles the cursor (see below) in a counter-clockwise direction
- Down arrow - Cycles the cursor in a clockwise direction
- Check mark - Activates the selected setting (if applicable) and saves the current configuration

Settings are changed using the cursor, visualized by a flashing indicator. To produce the cursor, the up or down arrow key must be pressed, causing one of the setting indicators to flash. Pressing or holding the Up or Down Arrow will move the cursor in the respective direction, as illustrated in Figure 3. Producing the cursor does not alter any settings without further user input, and the cursor will automatically timeout if the keypad is not used.

Once the cursor has been positioned over a desired setting, pressing and holding the check mark for 1 second or more will activate the selected setting. Attempting to activate a setting that is already active will have no additional effect.

4.1.2 Description of Settings

4.1.2.1 Input Signal Type

Input signals position the valve under control, based on the magnitude of the signal. During normal operation, the minimum value corresponds to the close position and the maximum value to the open position. Reverse Acting Mode inverts this relationship (maximum value = close position, minimum value = open position). Only one input signal can be active at a time.

Input setting	Description
4-20mA (default)	Analog Current Range
	Minimum: 4mA Maximum: 20mA
0-10V	Analog Voltage Range
	Minimum: 0V Maximum: 10V
0-5V	Analog Voltage Range
	Minimum: 0V Maximum: 5V
2-10V	Analog Voltage Range
	Minimum: 2V Maximum: 10V

Figure 3:
Servo NXT
Input settings

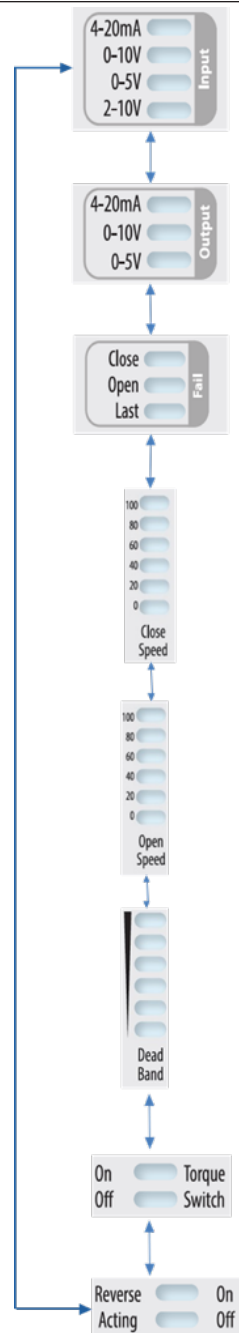

4.1.2.2 Output Signal Type

Output signals report the position of the valve under control, based on the magnitude of the signal. The minimum value corresponds to the close position and the maximum value to the open position. Only one output signal can be active at a time.

Output setting	Description
4-20mA (default)	Analog Current Range
	Minimum: 4mA
	Maximum: 20mA
0-10V	Analog Voltage Range
	Minimum: 0V
	Maximum: 10V
0-5V	Analog Voltage Range
	Minimum: 0V
	Maximum: 5V

Figure 4 - Servo NXT Output settings

4.1.2.3 Failure Position

The Failure Position determines how the Servo NXT positions the valve upon loss of input signal. Loss of input signal occurs when the input signal received is outside the valid range of the selected Input Signal Type, e.g. an input signal of less than 4mA for the 4-20mA input. Only one failure position can be active at a time.

Fail setting:	Description:
Close	Valve is closed on loss of input signal
Open	Valve is opened on loss of input signal
Last (default)	Position valve at the last valid commanded position before loss of input signal

Figure 5 - Servo NXT Fail Settings

4.1.2.4 Close Speed Control

Close Speed Control determines how quickly the Servo NXT operates the actuator in the close direction. This value is a percentage of the full speed. The illuminated indicators act as a level gauge: activating a speed setting illuminates all lower speed setting indicators. Maximum speed illuminates all indicators, while minimum speed illuminates only one.

Close Speed Setting	Description
0% - 100% (default) Step size: 20%	Actuator close speed as a percentage of full speed

Figure 6 - Servo NXT Close Speed Setting

4.1.2.5 Open Speed Control

Open Speed Control determines how quickly the Servo NXT operates the actuator in the open direction. This value is a percentage of the full speed. The illuminated indicators act as a level gauge: activating a speed setting illuminates all lower speed setting indicators. Maximum speed illuminates all indicators, while minimum speed illuminates only one.

Open Speed Setting	Description
0% - 100% (default) Step size: 20%	Actuator open speed as a percentage of full speed

Figure 7 - Servo NXT Open Speed Setting

4.1.2.6 Dead Band Control

Dead Band Control determines the acceptable offset between the position command provided by the input command and the current position of the actuator, determined from the feedback signal provided by the potentiometer. This value is a percentage of the full input range, and creates an inactive area centered around the desired set point. For example, for a 0-10V input command, a 2% Dead Band Control setting allows the actuator position to be offset from the desired set point by up to 0.1V in either direction, creating a dead band with a span of 0.2V. The illuminated indicators act as a level gauge: activating a dead band setting illuminates all lower dead band setting indicators. Maximum dead band illuminates all indicators, while minimum dead band illuminates only one.

Dead Band Setting	Description
1% - 6% 3% (default) Step size: 1%	Acceptable offset between command position and actuator position

Figure 8 - Servo NXT Dead Band Setting

4.1.2.7 Torque Switch Detection

Torque Switch Detection determines whether the Servo NXT is responding to changes to the torque switch assembly. When on, the Servo NXT will stop the actuator if a torque switch is engaged, signaling that the actuator is operating at torques above its rated torque. This setting should only be activated if torque switches are connected to the Servo NXT.

Torque Switch Setting	Description
On	Actuator movement stopped if the torque switch engages
Off (default)	Torque switch state ignored

Figure 9 - Servo NXT Torque Switch Settings

4.1.2.8 Reverse Acting Mode

Reverse Acting Mode determines how the Servo NXT responds to input commands. When on, the Servo NXT will operate inversely to how it operates normally, treating the maximum input signal value as the close command and the minimum input signal as the open command. This setting does not affect the output signal.

Reverse Acting Setting	Description
On	Servo NXT responds inversely to input commands
Off (default)	Servo NXT responds normally to input commands

Figure 10 - Servo NXT Reverse Acting Mode Settings

4.1.3 Motor Stall Detection

A standard feature on the Servo NXT is motor stall detection. If the feedback signal provided to the Servo NXT by the potentiometer does not match the expected operation, then a fault state is entered.

More specifically, if the actuator controlled by the Servo NXT is operating the motor either open or close and the feedback potentiometer does not detect any movement, a Motor Stall Fault will occur. This most often occurs when the travel of the actuator is impeded due to excessive valve torque or a blockage in the valve flow stream. When a Motor Stall Fault occurs, the actuator will move in the opposite direction of travel from where the fault occurred for 2 seconds. This relieves the actuator and underlying valve from any static torque load. After this movement, the actuator will stop and continuously flash all five fault indicators simultaneously. The actuator will not respond to further commands and will remain in this state until the handwheel is engaged. After the handwheel is engaged and then disengaged, the actuator will resume normal operation.

In rare cases, it may be desirable to disable this feature. The Motor Stall Detection feature can be disabled by simultaneously pressing and holding the Up and Down Arrow keys for 5 seconds. After 5 seconds, the 5 fault indicators will flash simultaneously for 1 second indicating that the feature has been disabled. The feature can be re-enabled by repeating the process. When the feature is re-enabled, all Valve Position indicators will flash simultaneously for 1 second.

4.2 Operating Modes

4.2.1 Remote Mode

By default, the operating mode of the Servo NXT is remote mode, where the valve is positioned based on input signals. Exiting another mode of operation generally results in the Servo NXT returning to remote mode.

4.2.2 Local Mode

Local Mode is entered if a connection is made to the Control Box terminals and a command signal is present. This allows the Servo NXT to be controlled by a local control box, mounted to or near the actuator. See the section on the control box for more information.

4.2.3 Manual Mode

This operating mode allows for the actuator to be controlled directly from the user interface on the Servo NXT. By utilizing the keypad, the user can change the position of the valve with a single button press.

Manual mode is exited in the same way it is entered: by pressing and holding the manual mode button for 1 second. While in manual mode, the indicator next to the manual mode button remains lit. Manual mode can only be entered during remote operation.

- Up arrow – Energizes the actuator in the open direction. The actuator will operate until it reaches the end of travel or the user presses the check mark key.
- Down arrow - Energizes the actuator in the close direction. The actuator will operate until it reaches the end of travel or the user presses the check mark key.
- Check mark – Sets the current actuator position as the command position. If the actuator is energized when the button is pressed, then it stops in place.

4.2.4 Autocalibration Mode

Autocalibration mode is entered by pressing and holding the Autocalibration button for at least 3 seconds. Entering Autocalibration mode starts the autocalibration sequence: a series of commands performed by Servo NXT on the actuator to determine the operating points. During the autocalibration sequence, the Servo NXT should be monitored to ensure it operates correctly. The product settings' indicators will change state to show that autocalibration has been entered, and will continue to flash at the end of travel until autocalibration completes. Upon completion of the autocalibration sequence, the product settings' indicators will return to normal.

- If the fault indication lights illuminate during autocalibration, then the autocalibration sequence could not be successfully completed. Refer to the troubleshooting section for more information.
- No other operating modes can be entered during autocalibration, and entering autocalibration mode will override any previous mode of operation.



CAUTION

The Servo NXT will not be remotely controllable during the autocalibration sequence. If autocalibration needs to be aborted, engage (pull out) the handwheel.

4.3 Status Indication

These are all indicators that report key information on the operation and functional status of the Servo NXT and actuator.

4.3.1 Valve Position

This string of indicators provides position information of the valve under control. In addition, if the actuator is operating the valve, then it also indicates the current command position and direction of travel.

- Direction indicators – The Open (green) and Close (red) indicators at both ends of the valve position indicator show the current direction of travel. When the actuator is energized, the corresponding indicator will flash to indicate travel. The green indicator will be lit if the open travel limit is reached. The red indicator will remain lit if the close travel limit is reached.
- Position indicators – The indicators between the direction indicators act as a level gauge, with the fully closed position serving as the zero point. Each indicator represents 15 degrees of travel, so that the total number of illuminated indicators shows the distance the valve is from the fully closed position. As the command signal is changed, a single indicator will flash which represents the relative level of the command signal. The indicators that remain solid represent the relative position of the actuator. Once the actuator reaches the command signal set point, the single command signal indicator will stop flashing. This scheme provides the operator an indication of both the command signal and actuator position using a single display.

4.3.2 Fault Status

These indicators in the lower left of the user interface illuminate in the event of a fault. The occurrence of a fault generally indicates that user intervention is required to restore operation, and these indicators attempt to provide the diagnostic information needed to accomplish this.

The Fault Status indicators are, from left to right:

- **Cmd Signal** – A valid input command is not present.
- **Limit Switch** – Both travel limit switches have been engaged, preventing the actuator from operating, or the travel limit switches are not correctly wired to the Servo NXT.
- **Hand Wheel** – The actuator handwheel has been engaged (pulled out), or the handwheel switch is not correctly wired to the Servo NXT.
- **FB pot** – The feedback potentiometer is outside its range of travel or is not correctly wired to the Servo NXT.
- **Torque Switch** – A torque switch has been engaged, or the torque switches are not correctly wired to the Servo NXT.

In addition, all the fault indicators can be flashing in unison. During autocalibration, this means that the autocalibration sequence has failed. During normal operation, this indicates that a motor stall fault has occurred. Refer to the section on Motor Stall Detection for more detail on a motor stall fault.

Refer to the Troubleshooting section for the actions required to clear a fault.

4.3.3 Bray Logo

The indicators that illuminate the Bray logo in the lower right of the user interface serve as status indicators for the Servo NXT. No matter what operation is performed, these indicators should be flashing on and off. If they are not flashing, refer to the Troubleshooting section.

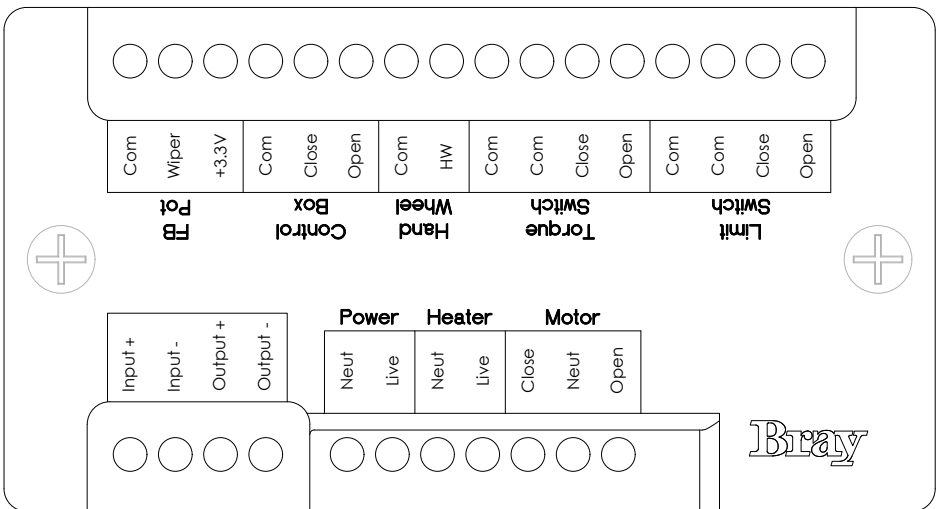

Figure 11: 120VAC / 230VAC Servo NXT terminal labels

5. Hardware Description

5.1 Terminal Connections



WARNING

Turn off all power and lockout/tag out service panel before installing or modifying any electrical wiring.

Terminals are provided on the unit for the landing of stripped wires, connecting the Servo NXT to the external sources and signals needed for it to successfully operate. These terminals are positioned on the unit based on physical location of the connecting components and the voltages expected at the connection. There are two categories that the terminal connections fall into: high/low voltage and customer/actuator connection. Connections of differing voltage levels are differentiated by their height on the Servo NXT, with high voltage connections being near the bottom of the unit and low voltage connections being near the top. Similarly, the customer and actuator connections are positioned such that they are easily accessible once the Servo NXT is installed in an actuator. Actuator connections are generally made at the factory, and should not require any customer adjustment. All connections required for proper operation are bolded below.

	Customer Connection	Actuator Connection
High voltage (> 15V)	Power	Heater, Motor
Low voltage (< 15V)	Input Signal (Input+, Input-) Output Signal (Output+, Output-)	FB Pot, Control Box, Hand Wheel, Torque Switch, Limit Switch

Figure 12: Terminal Connection categories

NOTICE

Refer to the actuator wiring diagram for wire gauge, torque, voltage, and temperature limits of the terminal blocks. All actuator connections should match the actuator wiring diagram.

5.1.1 Power

Power connection that energizes the Servo NXT and powers the actuator under control. The voltage supplied should be based on the actuator nameplate voltage and the voltage listed on the Servo NXT label.



CAUTION

Verify that the actuator nameplate voltage and the Servo NXT label voltage match before providing power to the unit.

The Servo NXT has an onboard protective fuse that is in line with the input power connection. This protective fuse is rated to 5A, the maximum allowable current draw for the Servo NXT. Therefore, the power supply connected to the input power connection should be rated to provide at least this much current to each Servo NXT.

5.1.2 Heater

If the actuator has an internal heater, then the heater wires are terminated at this connection. The heater will be powered by the input power connection. Only Bray supplied heaters should be connected to the Servo NXT.

5.1.3 Motor

Connections for the motor that operates the actuator. Refer to the actuator manual for more information on the motor.

5.1.4 Input Signal

Connection for the input signal that positions the valve under control, based on the magnitude of the signal. The signal that is present at this connection should be based on the input setting (see Product Settings).

Input signals are polarized, so that miswiring may result in unexpected behavior. Ensure that the wiring diagram is followed when making this connection.

5.1.5 Output Signal

Connection for the output signal that reports the position of the valve under control, based on the magnitude of the signal. The signal that is present at this connection is based on the output setting (see Product Settings).

Output signals are polarized, so that miswiring may result in unexpected behavior. Ensure that the wiring diagram is followed when making this connection.

NOTICE

The output signal is powered by the Servo NXT. An external source should never be connected to the terminals.

5.1.6 FB Pot

Connections for the Feedback Potentiometer, used by the controller to determine the position of the valve.

The Servo NXT provides a logic level voltage across the potentiometer, and then monitors the voltage that is returned on the wiper connection. The wiper voltage will change as the potentiometer is turned, due to the rotation of the cam shaft. During autocalibration, the Servo NXT can save the wiper voltage range and use it to position the actuator accurately and precisely.

NOTICE

The Servo NXT has been programmed to monitor a specific range of feedback voltage. Utilizing a potentiometer other than the factory provided potentiometer may result in unexpected behavior.

NOTICE

Servo NXT feedback potentiometer voltage may be measured between terminals "C" and "PW". Voltage must be between 0.1 Volts and 3.1 Volts for valve closed and opened positions respectively. Refer to the S70 Electric Actuator IOM for potentiometer alignment instructions.

5.1.7 Control Box

Connections for the local control station, if present. The local control station allows for local operation of the actuator, putting the Servo NXT in local mode and overriding remote input commands.

The Servo NXT provides a logic level voltage at the Open and Close terminals of this connection. If a switch connects either of the terminals to the COM terminal, this pin will be pulled to 0V, signaling the Servo NXT to enter local mode. The Servo NXT will not exit local mode until the Open and Close terminals return to their original voltage level. Once in local mode, the Servo NXT will ignore input commands until remote operation resumes.

5.1.8 Hand Wheel

Connections for the handwheel override switch. When the actuator handwheel is engaged (pulled out), this switch prevents the actuator from operating until the handwheel is disengaged.

The Servo NXT provides a logic level voltage at the HW terminal of this connection. If the handwheel is engaged (pulled out), this pin will get pulled to 0V, signaling the Servo NXT and resulting in a fault.

5.1.9 Torque Switch

Connections for the torque switch assembly, if present, which alert the Servo NXT to the presence of excessive torque applied to the actuator.

The Servo NXT provides a logic level voltage at the Open and Close terminals of this connection. If the actuator torque increases above the rated torque, the switch at the applicable connection will pull this pin to 0V, signaling the Servo NXT to enter a fault condition.

5.1.10 Limit Switch

Connections for the travel limit switches, which indicate to the Servo NXT when an end of travel set point has been reached.

The Servo NXT provides a logic level voltage at the Open and Close terminals of this connection. Once one of the travel limit switches is engaged, the switch at the applicable connection will engage and pull this pin to 0V, signaling the Servo NXT to end travel.

For proper operation, both travel limit switches should not be engaged at the same time. This would prevent the Servo NXT from operating the actuator, and results in a fault condition.

NOTICE

Low voltage, actuator connections are powered by the Servo NXT. An external source should never be connected to these terminals. Refer to the actuator manual for more information on these components, or if these components need to be repaired or replaced

7. Troubleshooting Guide

Refer to the actuator manual before adjusting or replacing any actuator components. Before testing or acting on any possible issues, check for any active faults.



WARNING

Turn off all power and lockout/tag out service panel before installing or modifying any electrical wiring.

Issue	Possible Causes	Possible Solutions
Servo NXT does not turn on when power is applied	Fuse is blown	Verify and replace fuse
	Servo NXT is incorrectly wired	Verify wire connections against the wiring diagram
	Servo NXT is not receiving power	Test the Input Power connection with a multimeter or oscilloscope
	Power is not correct	Check the provided power against the voltage listed for the Servo NXT and actuator
Actuator moves back and forth near setpoint (hunting)	Deadband is too narrow	Increase the deadband setting
	Excessive noise on the signal lines	Use an oscilloscope to test for the presence of EMI. Utilize EMI reducing techniques to mitigate the issue.
Servo NXT not responding to command signal	Servo NXT in local mode	If local control is being used , ensure the local control station is not active or is set to remote mode. If local control is not being used , test the voltage on the Control Box Open and Close pins relative to the COM pins. Greater than 3V should be measured.
	Servo NXT in manual or autocalibration mode	Check the indicators for manual and autocalibration mode
	Servo NXT is incorrectly wired	Verify wire connections against the wiring diagram

Fault Condition	Possible Causes	Possible Solutions
Cmd Signal Fault	Command signal does not match Input setting	Adjust the Input setting to match the command signal used
	Servo NXT is incorrectly wired	Verify wire connections against the wiring diagram
	Servo NXT is not receiving the command signal	Test the Input Command connection with a multimeter or oscilloscope
Limit Switch Fault	Both limit switches are engaged	Adjust actuator cams
	Servo NXT is incorrectly wired	Verify wire connections against the wiring diagram
	Travel limit switch failure	Test the switches to ensure that they are changing states when engaged.
Hand Wheel Fault	Hand Wheel is engaged	Disengage (push in) hand wheel
	Servo NXT is incorrectly wired	Verify wire connections against the wiring diagram
	Hand wheel switch failure	Test the switch to ensure that it is changing states when engaged.
FB Pot Fault	Potentiometer outside of travel range	Operate the actuator to the fully open and fully closed position, and adjust the potentiometer position as needed
	Servo NXT is incorrectly wired	Verify wire connections against the wiring diagram
Torque Switch Fault	Torque Switch setting enabled with no torque switches connected	Disable torque switch setting
	Torque switch(es) engaged	Check the valve and/or actuator for obstructions.
	Servo NXT is incorrectly wired	Verify wire connections against the wiring diagram
	Torque Switch failure	Test the switches to ensure that they are changing states when engaged.
Motor Stall Fault	Operational torque is exceeding the torque rating of the actuator	Check the valve and/or actuator for obstructions. Measure the torque required to rotate the valve and verify against the rated torque.
	Servo NXT is incorrectly wired	Verify wire connections against the wiring diagram
Fault condition during autocalibration	Fault occurring during calibration	Operate the actuator to the fully open and fully closed position, and correct any faults that occur
	Servo NXT is incorrectly wired	Verify wire connections against the wiring diagram

Bray CONTROLS

A Division of BRAY INTERNATIONAL, Inc.

13333 Westland East Blvd. • Houston, Texas 77041

Tel: 281.894.5454 Fax: 281.894.9499 www.bray.com

All statements, technical information, and recommendations in this bulletin are for general use only. Consult Bray representatives or factory for the specific requirements and material selection for your intended application. The right to change or modify product design or product without prior notice is reserved. Patents issued and applied for worldwide.

Bray® is a registered trademark of Bray International, Inc.

© 2017 Bray International, Inc. All rights reserved.

IOM_S70ServoNXT_Modulating Controller_5-2017