



DC(M)S-62 Series — Installation Instructions

06/30/22

Description The DC(M)S-62 direct-coupled spring return electronic actuator is designed for modulating, two-position, and three-position control of building HVAC dampers.

- Features**
- Brushless DC motor technology with stall protection
 - Bi-directional fail-safe spring return
 - Models available with dual, independently adjustable auxiliary switches
 - Unique self-centering shaft coupling
 - Manual override
 - Available in 62 lb-in torque
 - 5° preload as shipped from factory
 - Mechanical range adjustment capabilities
 - UL and cUL listed, CE certified

Application Used in constant or variable air volume installations for the control of return air, mixed air, exhaust, and face and bypass dampers requiring up to 62 lb-in (7 Nm) torque.

Designed for applications that require the damper to return to a fail-safe position when there is a power failure.

Operation **DCMS24-62 Modulating**
Apply a continuous 0 to 10 Vdc control signal between wire 8 (Y) and wire 2 (G0) to operate the damper actuator. The angle of rotation is proportional to the control signal.
A 0 to 10 Vdc position feedback output signal is available between wire 9 (U) and wire 2 (G0) to monitor the position of the damper motor.
In the event of a power failure or when the operating voltage is shut off, the actuator returns to the "0" position.

DCS24-62 2-Position
When power is applied, the actuator coupling moves toward the open position "90°". In the event of a power failure or when the operating voltage is shut off, the actuator returns to the "0" position.

DCS24-62-T, 3-Position
A floating control signal controls the damper actuator. The actuator's angle of rotation is proportional to the length of time the signal is applied. A 24 Vac/dc control signal to wire 6 (Y1) causes the actuator coupling to rotate clockwise. A 24 Vac/dc control signal to wire 7 (Y2) causes the actuator coupling to rotate counterclockwise.
With no control voltage, the damper actuator holds its position. In the event of a power failure, the actuator spring returns to the "0" position.

Operation In the event of a blockage in the damper, the actuator is overload protected over the full range to prevent damage to the actuator.

Life Expectancy An improperly tuned loop will cause excessive repositioning that will shorten the life of the actuator.

Actuator Components

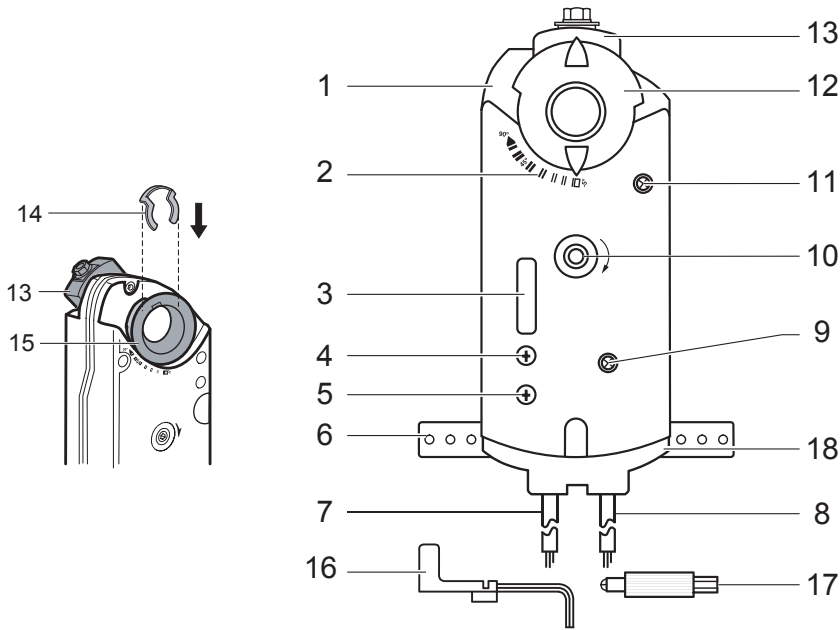
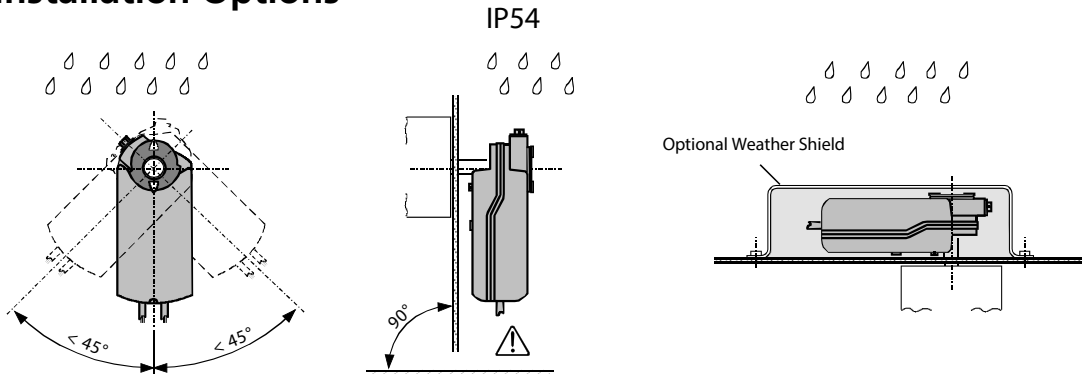

Figure 1. Components of the DCS-62 Spring Return Actuator.

Legend

1. Actuator housing
2. Positioning scale for angle of rotation
3. DIP switches and cover
4. Span adjustment
5. Offset (start point) adjustment
6. Mounting bracket
7. Connection cable for power and control signals
8. Connection cable for auxiliary switches or feedback potentiometer
9. Gear train lock pin
10. Manual override wrench opening and direction of rotation arrow
11. Auxiliary switches A and B
12. Position indicator
13. Self-centering shaft adapter
14. Shaft adapter locking clip
15. Position indicator adapter
16. Key for manual adjustment
17. Adjustment tool for: auxiliary switches (11), offset/span (4 and 5), and lock pin (9)
18. 1/2-inch NPT conduit connections

Warnings/Installation Options



Adapter

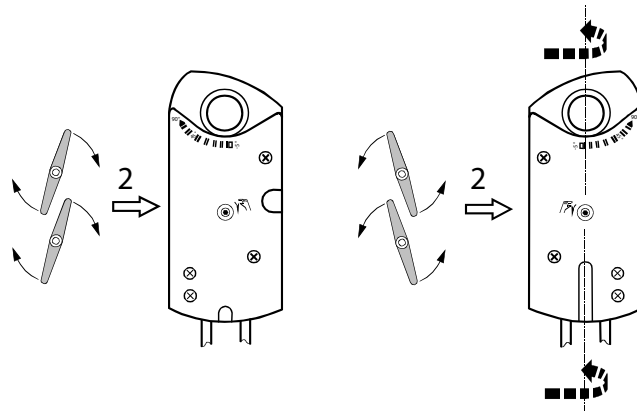

Adaptor Mounting

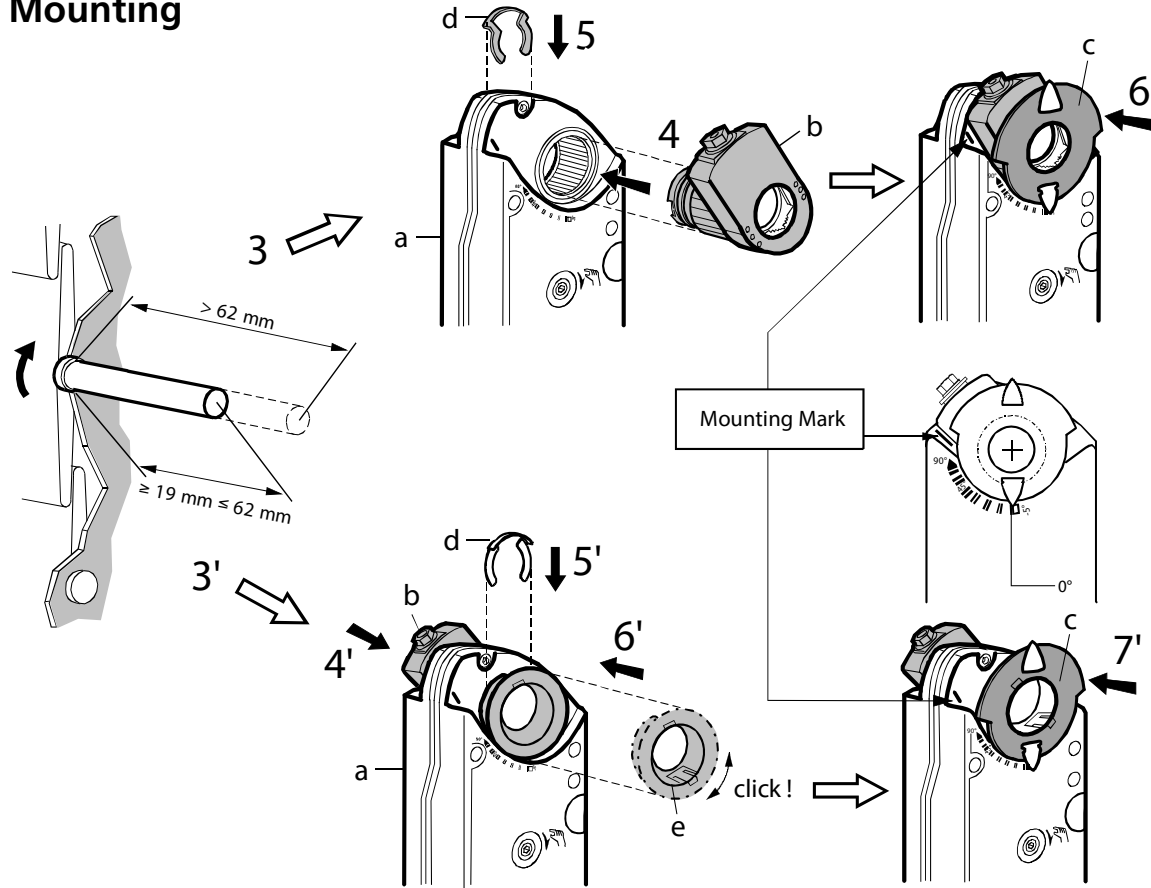

Mechanical Range Adjustment

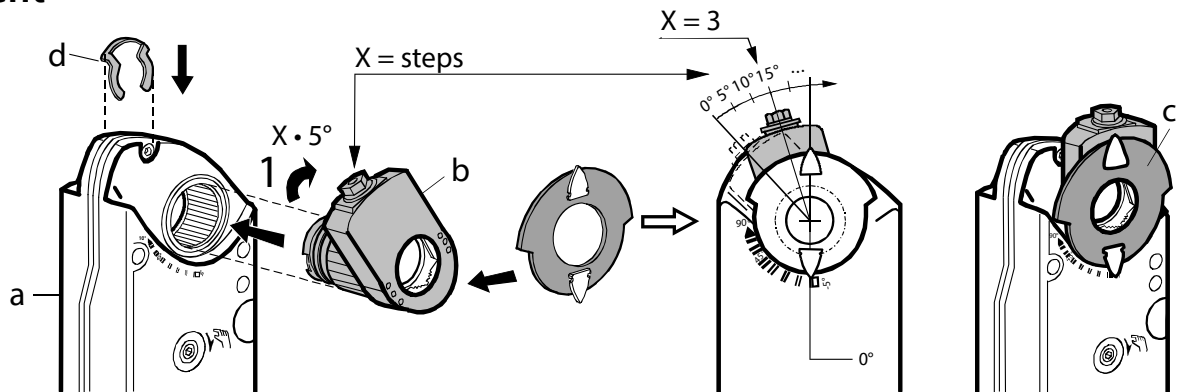

Figure 3. Mechanical Range Adjustment.

The angular rotation is adjustable between 0 and 90° at 5-degree intervals.

To limit the range of shaft movement:

1. Remove the locking clip and self-adjusting shaft adapter.
2. Rotate the damper blade shaft to its failed position.
3. Rotate the shaft coupling to the desired position.
4. Insert the shaft adapter into the actuator and fasten it with the locking clip. See Figure 3.

Shaft Mounting

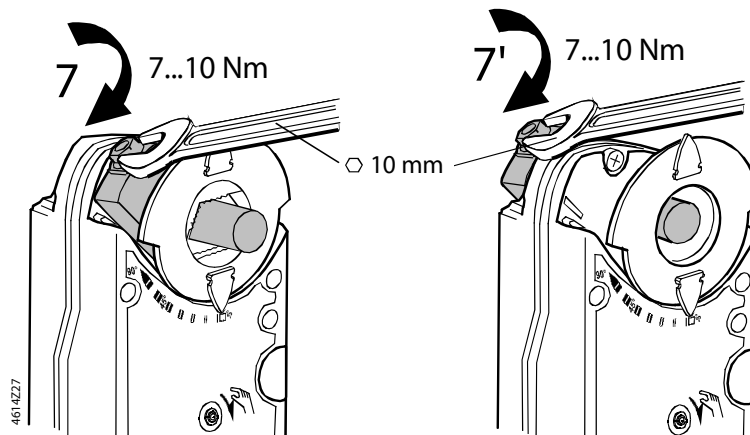
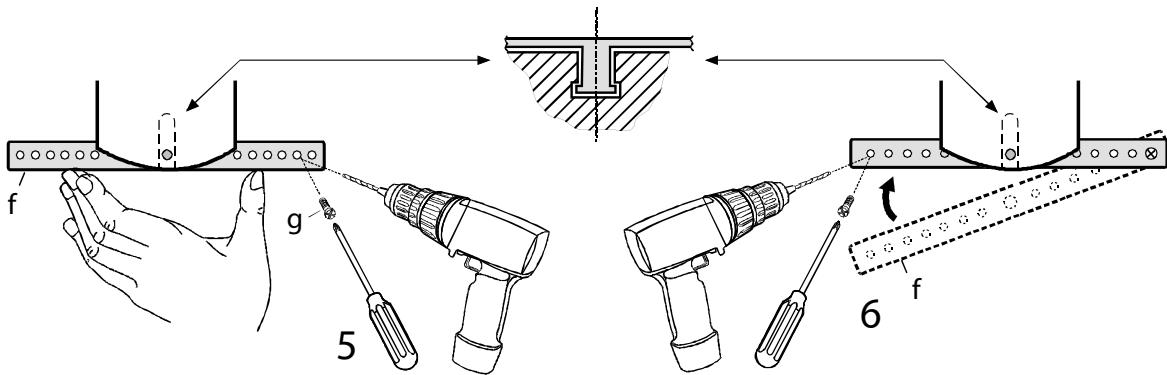
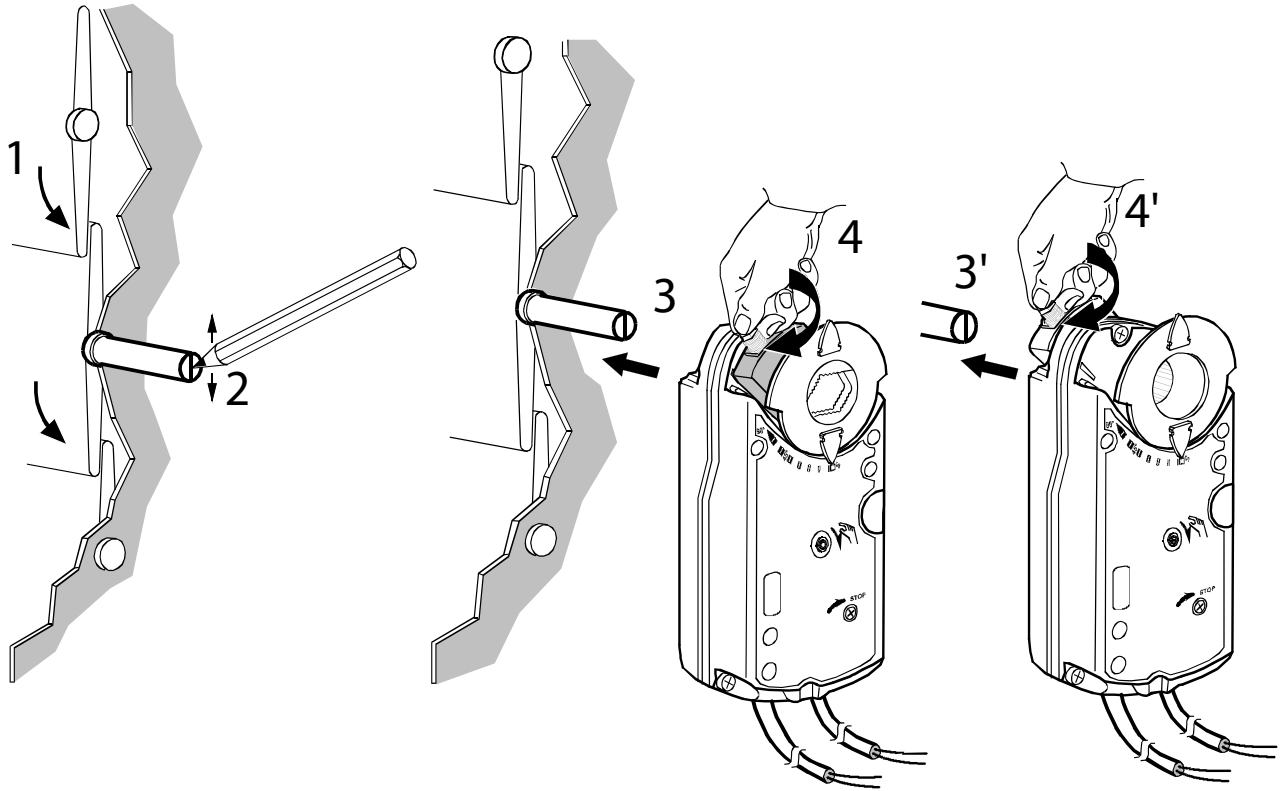

4614227

Manual Override

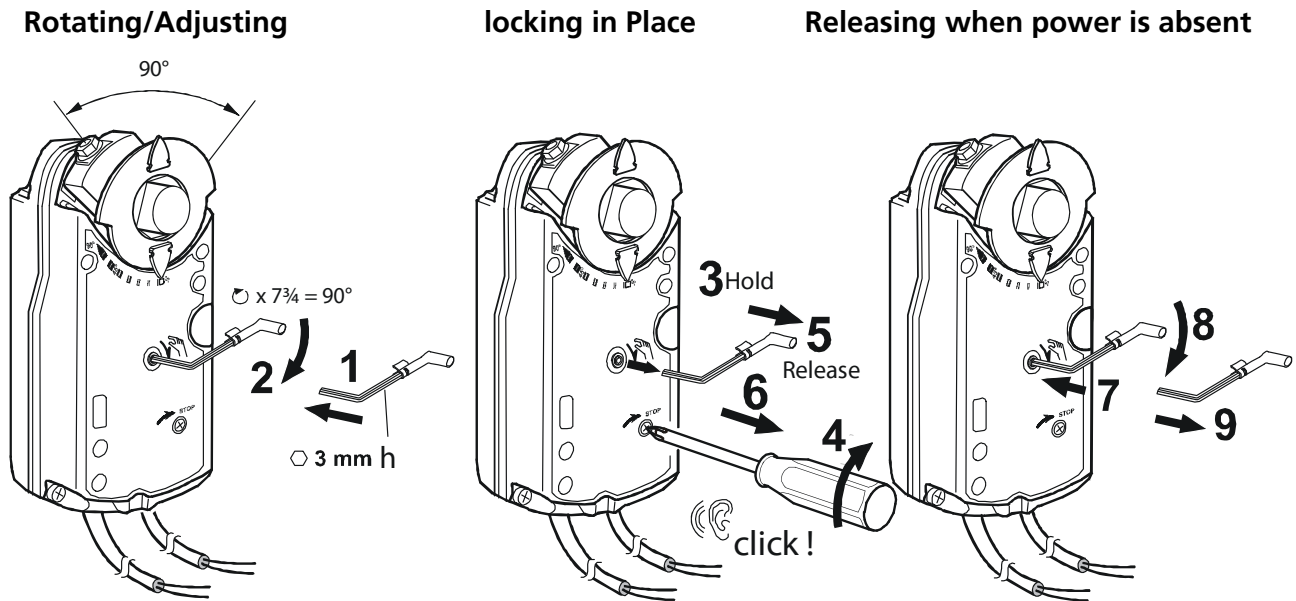

NOTE: Always turn the key in the direction of the arrow.

CAUTION:



When engaging the gear train lock pin, carefully turn only about 5 degrees until you meet slight resistance. Turning too far will strip the lock pin.

To Release Manual Override

Do one of the following:

- Restore power and send a control signal.
- When power is absent, do the following:
 1. Insert the 3 mm hex key in the override opening.
 2. Turn the key in the direction of the arrow.
 3. Remove the key.

Manual Override

Setting: Auxiliary switches A, B

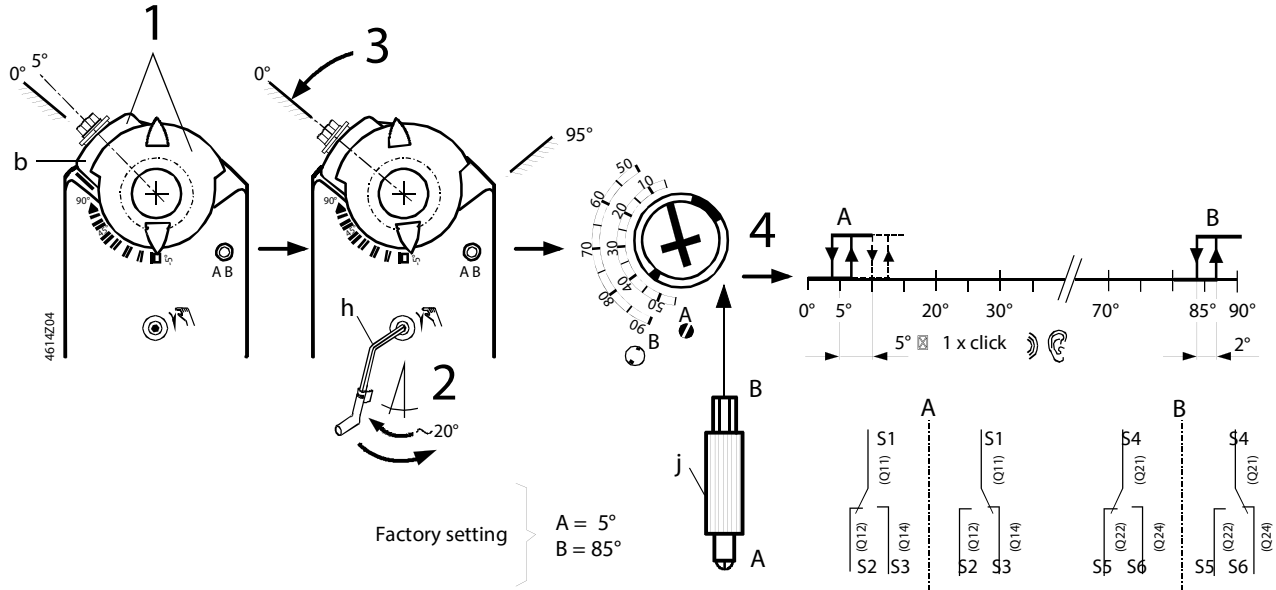

Dual Auxiliary Switch

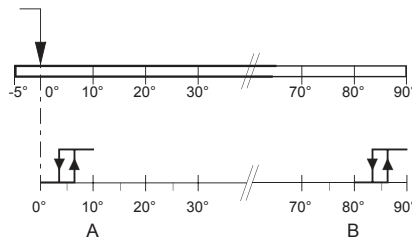

Actuator rotary range with the adapter mounted at position "0".

Setting range for switches A and B
Setting interval: 5°
Switching hysteresis: 2°

To change the settings of A and B:

- Make sure the actuator is in the "0", fail safe position. The scale is valid only in the "0" position.
- Use the adjustment tool provided with the actuator to turn the switch adjustment dials to the desired setting at which a signal is to be given.

Factory setting
Switch A = 5°
Switch B = 85°

NOTE: Use the long arm of the "T" to point to the position of switch A. Use the narrower tab on the red ring to point to the position of switch B

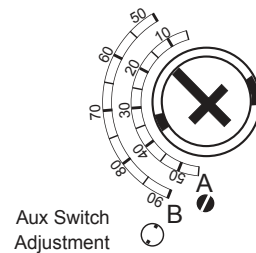
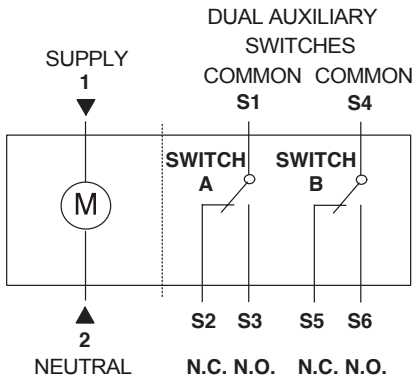

Figure 6. Adjustable Switching Values for the Dual Auxiliary Switches.

DC(M)S-62 Series — Installation Instructions - Continued

Wiring

On/O with AUX Switches



Modulating with AUX Switches

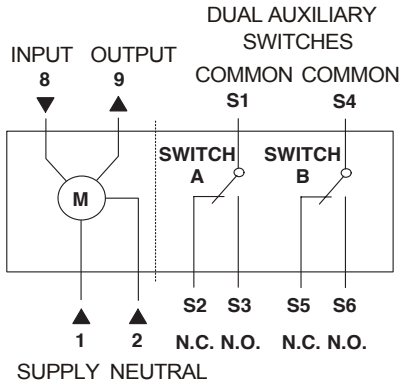

120 V On/O with AUX Switches

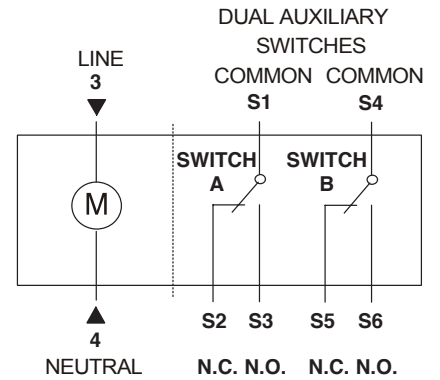

On/O & Floating with AUX Switches

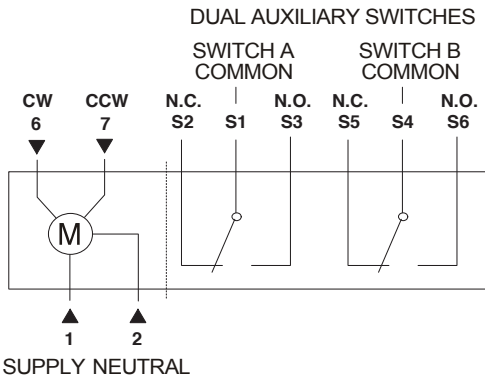

On/O

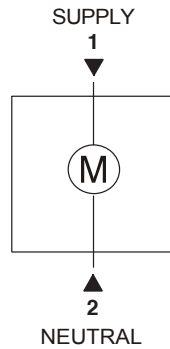

Modulating

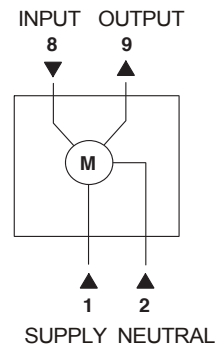

Dimensions

