

03251547

Honeywell

USA CAN MEX
→ www.docuthek.com

Operating instructions

Gas pressure switches C6097A, C6097B



Cert. version 05.18

Safety

Please read and keep in a safe place



Please read through these instructions carefully before installing or operating. Following the installation, pass the instructions on to the operator. This unit must be installed and commissioned in accordance with the regulations and standards in force. These instructions can also be found at www.docuthek.com.

Explanation of symbols

- , **1**, **2**, **3**... = Action
- ▷ = Instruction

Liability

We will not be held liable for damage resulting from non-observance of the instructions and non-compliant use.

Safety instructions

Information that is relevant for safety is indicated in the instructions as follows:

⚠ DANGER

Indicates potentially fatal situations.

⚠ WARNING

Indicates possible danger to life and limb.

! CAUTION

Indicates possible material damage.

All interventions may only be carried out by qualified gas technicians. Electrical interventions may only be carried out by qualified electricians.

Conversion, spare parts

All technical changes are prohibited. Only use OEM spare parts.

Checking the usage

Gas pressure switches C6097 for monitoring increasing and decreasing gas or air pressure.

C6097A: switches with falling pressure,

C6097B: switches with rising pressure.

	Positive pressure	Negative pressure
C6097A	Gas, air, flue gas, biogas	Air, flue gas
C6097B	Gas, air, flue gas, biogas	Air, flue gas

Pressure switches with manual reset lock off after switching. They can be unlocked using the manual reset.

This function is only guaranteed when used within the specified limits – see page 5 (Technical data). Any other use is considered as non-compliant.

Part designations

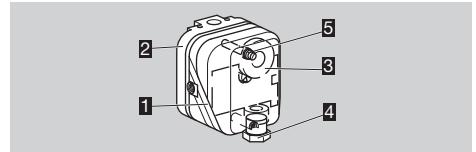

- 1** Upper housing section with cover
- 2** Lower housing section
- 3** Hand wheel
- 4** ½" NPT conduit coupling
- 5** Manual reset
(only on C6097A3012, C6097A3038, C6097A3095, C6097A3111, C6097B3002, C6097B3028, C6097B3051 and some customer specific variants)

Type label

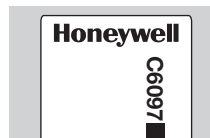

Approval and type: see type label.

For detailed information on the adjusting range, mean switching differential, max. inlet pressure, lock-off, medium and switching properties, see page 6 (Type table).

Installation

! CAUTION

Please observe the following to ensure that the C6097 is not damaged during installation and operation:

- Continuous operation with gases containing more than 0.1 %-by-vol. H₂S or ozone concentrations exceeding 200 µg/m³ accelerate the ageing of elastomer materials and reduce the service life.
 - Use approved sealing material only.
 - Dropping the device can cause permanent damage. In this event, replace the entire device and associated modules before use.
 - Check max. ambient temperature – see page 5 (Technical data).
 - When using silicone tubes, only use silicone tubes which have been sufficiently cured.
 - Vapours containing silicone can adversely affect the functioning of electrical contacts.
 - Condensation or vapours containing silicone must not be allowed to get into the housing. At subzero temperatures, malfunctions/failures due to icing can occur.
 - When installing outdoors, place the C6097 in a roofed area and protect from direct sunlight (even IP 65 version).
 - Avoid strong impact on the unit.
- ▷ Installation position as required, preferably with vertical diaphragm. Then the switching point p_S corresponds to the scale value SK set on the hand wheel. In other installation positions, the switching point p_S will change and no longer correspond to the scale value SK set on the hand wheel. Check the switching point.

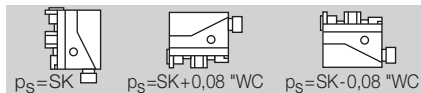

! CAUTION

If port **4** is at the top, IP 65 will not be satisfied.

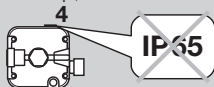

- ▷ The C6097 must not be in contact with masonry. Minimum clearance 1" (25 mm).
 - ▷ Ensure that there is sufficient installation space.
 - ▷ Ensure unobstructed view of the hand wheel.
- 1** Disconnect the system from the electrical power supply.
 - 2** Shut off the gas supply.
 - 3** Ensure that the pipeline is clean.

Ports

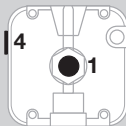

1 for positive pressure (1/4" NPT)

4 for negative pressure (1/8" NPT)

	Connect	Free
Positive pressure C6097	1	4
Negative pressure C6097	4	1
Differential pressure C6097	1 for higher absolute pressure. 4 for lower absolute pressure.	

! CAUTION

Port **4** connects the upper diaphragm chamber with the micro switch. Do not connect port **4** to pipes carrying gas.

- ▷ The pressure switches are supplied with an integrated vent limiter. In the event of a diaphragm tear, the vent limiter limits the escape of gas to less than 1.0 CFH of natural gas at 7 psi. If necessary, port **4** (1/8" NPT) can be used to connect the venting line.
- ▷ A filter pad at port **4** protects the electrical contacts in the C6097 from dirt particles in the surrounding air or in the medium.

Wiring

! CAUTION

To ensure that the C6097 is not damaged during operation, note the switching capacity, see page 5 (Technical data).

- ▷ In the case of low switching capacities, such as 24 V, 8 mA, for example, we recommend using an RC module (22 Ω, 1 μF) in air containing silicone or oil.
- 1** Disconnect the system from the electrical power supply.

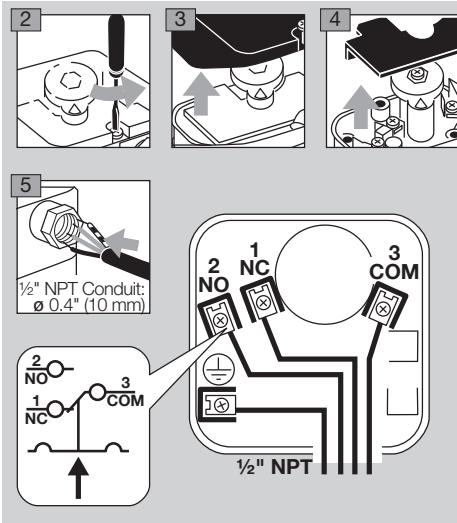

- ▷ C6097A: the NO-to-COM connection is interrupted if the pressure drops (contacts **3** and **2** open).
- C6097B: the NC-to-COM connection is interrupted if the pressure rises (contacts **3** and **1** open).

Adjustment

- ▷ The switching point is adjustable via hand wheel.
- 1** Disconnect the system from the electrical power supply.
 - 2** Detach the housing cover.
- ▷ Tightening torques, see Technical Information bulletin C6097 at www.docuthek.com.
- 3** Connect an ohmmeter.

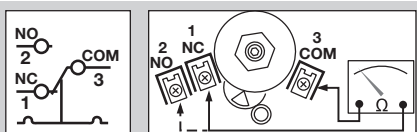

- 4** Set the switching point using the hand wheel.
- 5** Connect a pressure gauge.

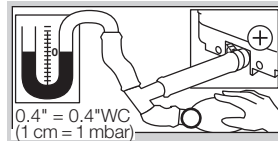

- 6** Apply pressure. In doing so, monitor the ohmmeter and the pressure gauge.
- ▷ Adjusting range, switching differential and max. inlet pressure, see page 6 (Type table).
 - ▷ If the C6097 does not trip at the desired switching point, correct the adjusting range using the hand wheel. Relieve the pressure and repeat the process.

Pressure switches with manual reset

- ▷ C6097A3012, C6097A3038, C6097A3095, C6097A3111 lock off if the pressure drops to the set value.
 - ▷ C6097B3002, C6097B3028, C6097B3051 lock off if the pressure rises to the set value.
- 1** Reset the pressure switch using the manual reset.
- ▷ Requirement for reset:
C6097A: the pressure must have risen at least to the set switching point plus the pressure differential between the switching pressure and possible lock-off.
C6097B: the pressure must have dropped at least to the set switching point minus the pressure differential between the switching pressure and possible lock-off.
- ▷ For details of the pressure differential between the switching pressure and possible lock-off, see page 6 (Type table).

Tightness test

- 1** Shut off the downstream gas pipeline close to the valve.
 - 2** Open the valve and the gas supply.
- ▷ Check all used ports for tightness.

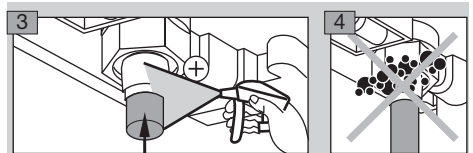

Maintenance

In order to ensure smooth operation, check the tightness and function of the C6097 every year, or every six months if operated with biogas.

Accessories

LED set, red/green

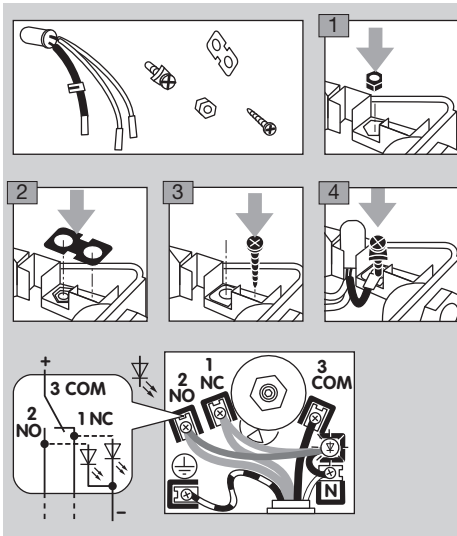

24 V DC, $I = 16 \text{ mA}$; 24 V AC, $I = 8 \text{ mA}$,
 Order No.: 32003048-003/U.
 110 to 230 V AC,
 Order No.: 32003049-003/U.

Pilot lamp set, blue

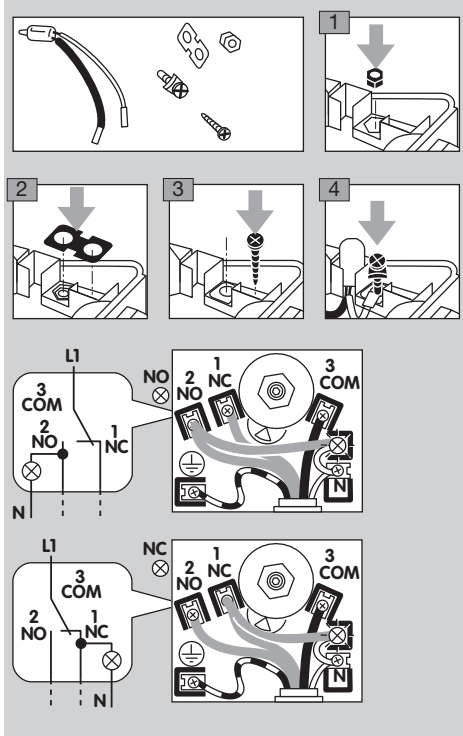

110/120 V AC, $I = 1.2 \text{ mA}$,
 Order No.: 32003045-003/U.

Further information about accessories can be found in Technical Information bulletin C6097 – www.docuthek.com

Technical data

Gas type: natural gas, town gas, LPG (gaseous), flue gas, biogas (max. 0.1 %-by-vol. H₂S) and air. Max. inlet pressure $p_{\max.}$ = withstand pressure, see page 6 (Type table).

Switching capacity:

	U	I (cos ϕ = 1)	I (cos ϕ = 0.6)
C6097	24–240 V AC	max. 5 A	max. 0.5 A

Storage temperature:

-4 to +104°F (-20 to +40°C).

Maximum medium and ambient temperatures:

-40 to +140°F (-40 to +60°C).

Long-term use in the upper ambient temperature range accelerates the ageing of the elastomer materials and reduces the service life (please contact manufacturer).

The set switching point may palpably change in media and ambient temperatures below -22°F (-30°C).

Storage temperature: -4 to +104°F (-20 to +40°C).

Diaphragm pressure switch, silicone-free.

Diaphragm: NBR.

Housing: glass fibre reinforced PBT plastic with low gas release.

Lower housing section: AISi 12.

Enclosure: IP 65. Safety class: 1.

Cable diameter: AWG 24 to AWG 13

(0.02 to 0.07" (0.5 to 1.8 mm)).

Line entrance: ½" NPT conduit.

Electrical connection type: screw terminals.

Max. tightening torque, see Technical Information bulletin C6097.

Weight: 9.5 to 11.3 oz (270 to 320 g).

Dimensions

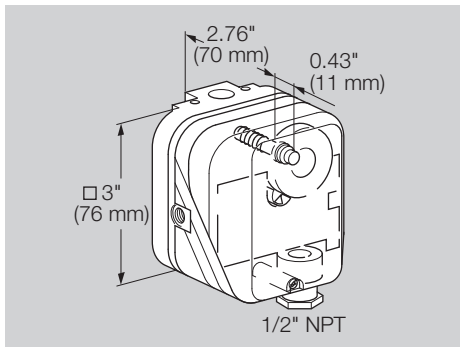

Logistics

Transport

Protect the unit from external forces (blows, shocks, vibration). On receipt of the product, check that the delivery is complete, see page 1 (Part designations). Report any transport damage immediately.

Storage

Store the product in a dry and clean place.

Storage temperature: see page 5 (Technical data).

Packaging

The packaging material is to be disposed of in accordance with local regulations.

Disposal

Components are to be disposed of separately in accordance with local regulations.

Certification

Directive on the restriction of the use of hazardous substances (RoHS) in China

Scan of the Disclosure Table China RoHS2 – see certificates at www.docuthek.com

FM approved



Factory Mutual Research Class: 3510 Flow and pressure safety switches.

Designed for applications pursuant to NFPA 85 and NFPA 86.

UL listed



UL 353 Limit control.

Underwriters Laboratories

Type table

Type	Adjusting range ¹⁾	Mean switching differential at min. and max. setting	Difference between switching pressure and possible lock-off	Max. inlet pressure		With lock-off	Medium	Switching properties at setpoint value	Connection
				No venting line	With venting line				
C6097A3004	0.4 – 4 "WC (1 – 10 mbar)	0.1 – 0.16 "WC (0.25 – 0.4 mbar)	-	7 psi (480 mbar)	8.5 psi (600 mbar)	No	Air/gas	1/4" NPT	
C6097A3012	1 – 20 "WC (2.5 – 50 mbar)	-	0.4 – 0.8 "WC (1 – 2 mbar)	7 psi (480 mbar)	8.5 psi (600 mbar)	Yes	Air/gas	1/4" NPT	
C6097A3038	12 – 60 "WC (30 – 150 mbar)	-	0.8 – 4.8 "WC (2 – 12 mbar)	7 psi (480 mbar)	8.5 psi (600 mbar)	Yes	Air/gas	1/4" NPT	
C6097A3053	1 – 20 "WC (2.5 – 50 mbar)	0.3 – 0.6 "WC (0.75 – 1.5 mbar)	-	7 psi (480 mbar)	8.5 psi (600 mbar)	No	Air/gas	1/4" NPT	
C6097A3079	12 – 60 "WC (30 – 150 mbar)	1.2 – 2 "WC (3 – 5 mbar)	-	7 psi (480 mbar)	8.5 psi (600 mbar)	No	Air/gas	1/4" NPT	
C6097A3095	0.4 – 4 "WC (1 – 10 mbar)	-	0.16 – 0.4 "WC (0.4 – 1 mbar)	7 psi (480 mbar)	8.5 psi (600 mbar)	Yes	Air/gas	1/4" NPT	
C6097A3111	40 – 200 "WC (100 – 500 mbar)	-	2 – 7.2 "WC (5 – 18 mbar)	7 psi (480 mbar)	8.5 psi (600 mbar)	Yes	Air/gas	1/4" NPT	
C6097A3137	40 – 200 "WC (100 – 500 mbar)	3.2 – 6.8 "WC (8 – 17 mbar)	-	7 psi (480 mbar)	8.5 psi (600 mbar)	No	Air/gas	1/4" NPT	
C6097B3002	12 – 60 "WC (30 – 150 mbar)	-	0.8 – 4.8 "WC (2 – 12 mbar)	7 psi (480 mbar)	8.5 psi (600 mbar)	Yes	Air/gas	1/4" NPT	
C6097B3028	1 – 20 "WC (2.5 – 50 mbar)	-	0.4 – 0.8 "WC (1 – 2 mbar)	7 psi (480 mbar)	8.5 psi (600 mbar)	Yes	Air/gas	1/4" NPT	
C6097B3051	40 – 200 "WC (100 – 500 mbar)	-	2 – 7.2 "WC (5 – 18 mbar)	7 psi (480 mbar)	8.5 psi (600 mbar)	Yes	Air/gas	1/4" NPT	
C6097B3085	12 – 60 "WC (30 – 150 mbar)	1.2 – 2 "WC (3 – 5 mbar)	-	7 psi (480 mbar)	8.5 psi (600 mbar)	No	Air/gas	1/4" NPT	
C6097B3101	40 – 200 "WC (100 – 500 mbar)	3.2 – 6.8 "WC (8 – 17 mbar)	-	7 psi (480 mbar)	8.5 psi (600 mbar)	No	Air/gas	1/4" NPT	
C6097B3119	1 – 20 "WC (2.5 – 50 mbar)	0.3 – 0.6 "WC (0.75 – 1.5 mbar)	-	7 psi (480 mbar)	8.5 psi (600 mbar)	No	Air/gas	1/4" NPT	

¹⁾ Adjusting tolerance = ± 15% of the scale value

Contact

If you have any technical questions, please contact your local branch office/agent. The addresses are available on the Internet or from Elster GmbH.

We reserve the right to make technical modifications in the interests of progress.

Honeywell

Elster GmbH
Strotheweg 1, D-49504 Lotte (Büren)
Tel. +49 541 1214-0

Fax +49 541 1214-370

hts.lotte@honeywell.com, www.kromschroeder.com