

# VRN Pressure Independent Control Valves and Actuators

## PRODUCT DATA



## APPLICATION

The VRN2 two-way dynamic pressure-regulating control valves maintain constant flow of hot or chilled water with glycol solutions up to 50% in closed-loop heating, ventilating, and air conditioning systems, within the specified pressure drop ranges of each model number. These valve assemblies can be ordered with or without factory-mounted actuators.

## FEATURES

- Sizes from 1/2 to 3 in. with internal (female) NPT connections.
- Controls hot or chilled water with up to 50% glycol.
- Regulated flow rates available from 1 to 95 gpm.
- Differential pressure regulator for constant pressure drop across valve seat.
- Positive pressure, rolling diaphragm regulator design for flow control accuracy of  $\pm 5\%$ .
- Equal percentage flow characteristic using patented flow control ball insert.
- Multiple maximum flow rates available per valve size.
- Patented ball seals for low operating torque.
- Nickel-chrome plated brass or stainless steel trim.
- Choice of factory-installed actuation using Honeywell MVN or MN/MS series direct coupled actuators: Floating, Modulating (2-10 V), Non-Spring Return and Spring Return.
- Spring return actuators field-configurable for normally open or normally closed fail-safe position.
- Removable, manual operating handle to control valve during installation or in an event of power failure.
- Upstream Test Port for venting or pressure gauge attachment.
- Three actuator orientations on the valve for cramped spaces.
- Integral snubber eliminates effect of system pressure fluctuations and entrapped air while improving flow performance.

## Contents

Application .....	1
Features .....	1
Specifications .....	2
Ordering Information .....	2
Typical Specifications .....	14
Installation .....	15
Operation and Checkout .....	21



## SPECIFICATIONS

**Valve Type:** Pressure Independent Control Valve

**Body Style:** Two-way ball valve, straight-through flow, full port with patented flow control insert.

**Pipe Size:** 1/2 to 3 inches with female NPT pipe fittings.

**Body Pressure Rating (maximum):** 360 psi (2500 kPa) at 250°F (121 °C).

**Controlled Medium:** Water or Glycol solutions up to 50%. Not suitable for combustible gases, oil or steam.

**Medium Temperature Range:** -22 to +250°F (-30 to +121 °C).

**Maximum Differential Pressure:** See Table 1.

**Close-off pressure:** 100 psid

### Flow Characteristics

Equal Percentage with flow control insert. See Fig. 40.

### Materials

**Body:** Forged Brass (ASTM B283).

**Flow Optimizer:** laser-milled, glass-reinforced Noryl®

**Trim (ball and stem):** Nickel-chrome plated brass, or stainless steel.

**Stem Seals:** EPDM O-ring and Teflon™ bearings.

**Ball Seals:** Reinforced Teflon™ seals, with EPDM O-rings.

**Regulator:** Hydrogenated acrylonitrile-butadiene rubber rolling diaphragm in stainless steel housing.

### Compatible Actuators

#### Minimum Torque Required:

35 lb-in. (4 N m) up to 3 in. (≤DN80).

27 lb-in. (3 N m) up to 1-1/4 in. (≤DN32).

**Fail Safe:** MSXX05\*

**Non-Fail Safe:** MVN & MNXX05\*

\* These actuators are available as factory-installed assemblies.

See Table 1 for all available options.

### Approvals Standards

**Actuators:** See literature for the given actuator.

## ORDERING INFORMATION

When purchasing replacement and modernization products from your TRADELINE® wholesaler or distributor, refer to the TRADELINE® Catalog or price sheets for complete ordering number. If you have additional questions, need further information, or would like to comment on our products or services, please write or phone:

1. Your local Honeywell Environmental and Combustion Controls Sales Office (check white pages of your phone directory).
2. Honeywell Customer Care  
1985 Douglas Drive North  
Golden Valley, Minnesota 55422-4386
3. <http://customer.honeywell.com> or <http://customer.honeywell.ca>

International Sales and Service Offices in all principal cities of the world. Manufacturing in Belgium, Canada, China, Czech Republic, Germany, Hungary, Italy, Mexico, Netherlands, United Kingdom, and United States.

**Table 1. VRN Model Selection.**

Model Selection: Pressure Independent Control Valve							Actuator	Fail Position	Accessories		
Valve	Fitting	Body/Flow Type	Size	Max flow rate	Trim	Actuator Adapter					
<b>VR</b> - Pressure Independent Control Valve							MVN613A0000*	Leave blank = Fail in place	C1 - 1 meter cable		
N - Female NPT threaded							MVN643A0000*				
2 - 2 way							MVN713A0000*				
A - 1/2 (DN15) B - 3/4 (DN20) C - 1 (DN25) D - 1-1/4 (DN32) E - 1-1/2 (DN40) F - 2 (DN50) G - 2-1/2 (DN65) H - 3 (DN80)							MN6105A1011				
							MN6105A1201				
							MN7505A2001				
xxx.xx - Max flow rate designator See Table 4.							MN7505A2209			FSD = Fail Safe Open FSC = Fail Safe Closed	3R - NEMA Enclosure
							MS7505A2030				
P - Plated Brass S - Stainless Steel							MS7505A2130				
							MS8105A1030				
A - Standard Base X - MN/MS DCA Actuator Bracket							MS8105A1130				
							MS4105A1030				
							MS4105A1130				
							MS7103A2024*				
							MS7103A2224*				
							MS3103A1023*				
							MS3103A1223*				
									Leave Blank = 3 ft cable standard		
<b>VR</b>	<b>N</b>	<b>2</b>	<b>A</b>	<b>001.00</b>	<b>P</b>	<b>A</b>	+	<b>MVN613A0000</b>	+	<b>C1</b>	

Example part number: **VRN2A001.00PA+MVN613A0000+C1**

\* Only compatible with valves 1-1/4" or smaller.

**Table 2. Actuator Control Description.**

<b>Actuator</b>	<b>Control</b>
MVN613A0000	Floating, Two-position (SPDT or SPST) (90 sec. timing), 24 V, Fail in Place
MVN643A0000	Floating, Two-position (SPDT) Fast Acting (30 sec. timing), 24 V, Fail in Place
MVN713A0000	Modulating, 24 V, Fail in Place
MN6105A1011	Floating, Two-position (SPDT), 24 V, Fail in Place
MN6105A1201	Floating, Two-Position (SPDT), 24 V, Fail in Place with end switches
MN7505A2001	Modulating, 24 V, Fail in Place
MN7505A2209	Modulating, 24 V, Fail in Place with end switches
MS7505A2030	Modulating, Floating, Two-position (SPDT), 24 V, Fail Safe
MS7505A2130	Modulating, Floating, Two-Position (SPDT), 24 V, Fail Safe with end switches
MS8105A1030	Two-Position (SPST), 24 V, Fail Safe
MS8105A1130	Two-Position (SPST), 24 V, Fail Safe with end switches
MS4105A1030	Two-Position (SPST), 120 V, Fail Safe
MS4105A1130	Two-Position (SPST), 120 V, Fail Safe with end switches
MS7103A2024	Modulating, 24 V, Fail Safe
MS7103A2224	Modulating, 24 V, Fail Safe with end switches
MS3103A1023	Sylk-enabled, 24 V, Fail Safe
MS3103A1223	Sylk-enabled, 24 V, Fail Safe with end switches

**Table 3. Pressure Independent Valve Short Order Codes 1/2" – 3".**

Model Selection: Control Valve						Actuator	Fail Position	Accessories	
Valve	Body Flow Type	Valve Size	Max Flow Rate	Trim	Actuator Adapter				
VRN - Pressure Independent Control Valve						<b>0</b> - No Actuator (valve only)	<b>0</b> - No Actuator or Fail in Place (FIP)	<b>00</b> - None	
2 - 2-way						<b>1</b> - 24 Vac, Floating/2-Pos., 90 sec. (MVN613, Fail in place)*		<b>00</b> - None <b>01</b> - 1 m Cable (C1)	
A---1/2 (DN15) B---3/4 (DN20) C---1 (DN25) D---1-1/4 (DN32) E---1-1/2 (DN40) F---2 (DN50) G---2-1/2 (DN65) H---3 (DN80)						<b>2</b> - 24 Vac, Floating/2-Pos., 30 sec. (MVN643, Fail in place)*			
						<b>3</b> - 24 Vac, Modulating 0(2)-10 Vdc (MVN713, Fail in place)*			
						<b>4</b> - 24 Vac, Floating/2-Position (MN6105, Fail in place)			
						<b>5</b> - 24 Vac, Mod. 0(2)-10 Vdc (MN7505, Fail in place)			
						<b>C</b> - 24 Vac, Floating/2-Position w/ end switches (MN 6105, Fail in place)			
						<b>D</b> - 24 Vac, Mod. 0(2)-10Vdc w/ end switches (MN7505, Fail in place)			
						<b>6</b> - 24 Vac, Mod. 0(2)-10 Vdc/Floating (MS7505, Fail safe)			<b>00</b> - None <b>02</b> - 3R - NEMA enclosure
Flow Rate (GPM) Options range from B-9. See Table 4.						<b>7</b> - 24 Vac, 2-Position (MS8105, Fail safe)			
P - Nickel Chrome Plated Brass						<b>8</b> - 100-250 Vac, 2-Position (MS4105, Fail safe)			
S - 316 Stainless Steel						<b>9</b> - 100-250 Vac, 2-Pos. w/ end switches (MS4105, Fail safe)			
						<b>A</b> - 24 Vac, 2-Position w/ end switches (MS8105, Fail safe)			
A - Standard Base						<b>B</b> - 24 Vac, Mod 0(2)-10 Vdc/Floating w/ end switches (MS7505, Fail safe)			
X - MN/MS DCA Actuator Bracket						<b>E</b> - 24Vac, Mod. 2-10 Vdc (MS7103, Fail safe)*			
						<b>F</b> - 24Vac, Mod. 2-10 Vdc w/ end switches (MS7103, Fail safe)*			
						<b>G</b> - 24Vac, Sylk Enabled (MS3103, Fail safe)*			
						<b>H</b> - 24Vac, Sylk Enabled w/ end switches (MS3103, Fail safe)*	<b>01</b> - 3 ft Cable		
<b>VRN</b>	<b>2</b>	<b>A</b>	<b>B</b>	<b>P</b>	<b>A</b>	<b>1</b>		<b>0</b>	<b>00</b>

Example part number: **VRN2ABPA1000**

\* Only compatible with valves 1-1/4" or smaller.



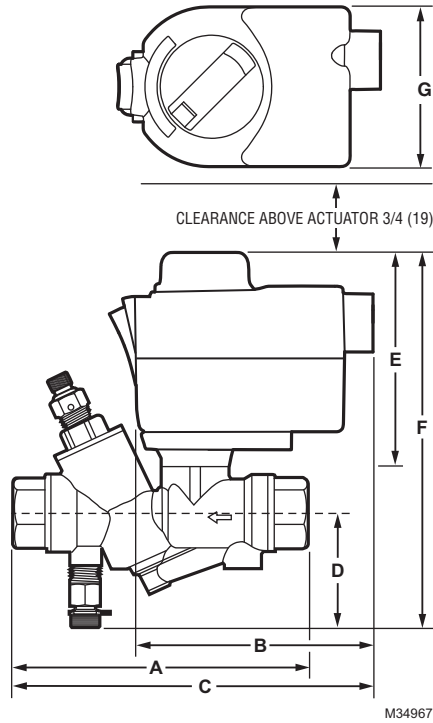
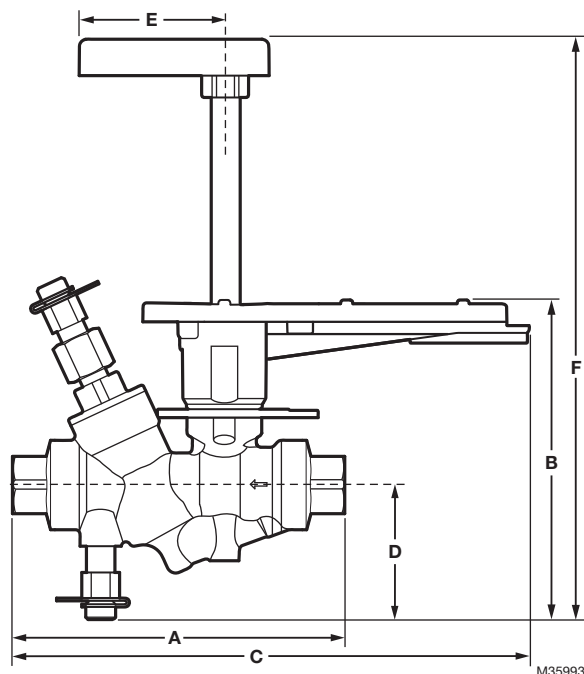


Fig. 1. Valve Dimensions with MVN Actuator; see Table 5.

Table 5. Valve Dimensions with MVN Actuator.

Model	Pipe Size		Flow, gpm (m <sup>3</sup> /h)			Dimensions in in. (mm)							Weight lb. (kg)	Service Replacement Parts
	NPT	in.	S.I. metric	Min. Rating	Max. Rating	Full Port	A	B	C	D	E	F		
VRN2A	1/2	DN15	1.0 (0.23)	7.0 (1.6)	10 (2.3)	5.71 (145)	4.56 (116)	6.57 (167)	2.32 (59)	3.87 (98)	7.36 (187)	2.8 (71)	2.5 (1.1)	Stem: 5112-19 5112-22 (SS <sup>a</sup> ); Regulator: 8615-100 for 1-3 gpm; 8615-101 for 4-10 gpm
VRN2B	3/4	DN20		9.0 (2.0)				6.63 (168)						
VRN2C	1	DN25		15.0 (3.4)	5.83 (148)									
			20 (4.5)	20 (4.5)	9.65 (245)	9.13 (232)	2.41 (61)	8.01 (203)	7.1 (3.2)	Stem: 5112-20 5112-23 (SS <sup>a</sup> ); Regulator: 8615-102				
VRN2D	1-1/4	DN32	10 (2.3)	30 (6.8)	35 (7.9)	8.98 (228)	8.79 (223)							

<sup>a</sup> Do not use stainless steel replacement stem assemblies in valves with plated brass trim; galvanic reactions may occur.



**Fig. 2. Dimensions of valves used with MN/MS actuators; see Table 6. Actuator not shown. See Figures 4 and 6 for MN/MS actuator dimensions.**

**Table 6. Dimensions of valves used with MN/MS actuators; see Fig. 2. See Figures 4 and 6 for MN/MS actuator dimensions.**

Model	Pipe Size		Flow, gpm (m <sup>3</sup> /h)			Dimensions <sup>c</sup> in in. (mm)							Weight lb. (kg)	Service Replacement Parts		
	NPT	in.	S.I. metric	Min. Rating	Max. Rating	Full Port	A	B	C	D	E	Fz <sup>a</sup>			Fs <sup>a</sup>	
VRN2A	1/2	DN15	1.0 (0.23)	7.0 (1.6)			5.71 (145)	5.43 (138)	8.87 (225)	2.32 (59)	2.5 (64)	10.02 (255)	8.77 (223)	2.5 (1.1)	Stem: 5112-19 5112-22 (SS <sup>b</sup> ); Regulator: 8615-100 for 1-3 gpm; 8615-101 for 4-10 gpm	
VRN2B	3/4	DN20		9.0 (2.0)	10 (2.3)											8.94 (227)
VRN2C	1	DN25		15.0 (3.4)			5.83 (148)		11.44 (291)							
VRN2D	1-1/4	DN32	10 (2.3)	30 (6.8)	35 (7.9)	8.98 (228) (213)	6.10 (155)	11.10 (282)	2.41 (61)	10.68 (271)		9.43 (240)	7.1 (3.2)	Stem: 5112-20 5112-23 (SS <sup>b</sup> ); Regulator: 8615-102		
VRN2E	1-1/2	DN40		35 (7.9)				8.80 (224)							11.01 (280)	
VRN2F	2	DN50	25 (5.7)	75 (17.0)		10.66 (271)	6.95 (177)	12.84 (326)	2.93 (74)	11.55 (293)		10.30 (262)	13.7 (6.2)	Stem: 5112-21 5112-24 (SS <sup>b</sup> ); Regulator: 8615-031		
VRN2G	2-1/2	DN65		85 (19.3)	95 (21.6)			10.97 (279)							13.00 (330)	
VRN2H	3	DN80		85 (19.3)	95 (21.6)			11.42 (290)							13.23 (336)	
						11.80 (300)		13.41 (341)								

<sup>a</sup> Long shaft supplied with “Zelix” direct coupled spring return actuators; short shaft supplied with MN series stay-in-place DCAs.

<sup>b</sup> Do not use stainless steel replacement stem assemblies in valves with plated brass trim; galvanic reactions may occur.

<sup>c</sup> Actuator dimensions fall within the envelope of the handle and mounting bracket. See actuator literature for detailed dimensions.

## MVN Actuator



## APPLICATION

MVN 3Nm (27 lb-in.) Control Valve Actuator is used with the VRN2 Pressure Independent Control Valves to control hot and chilled water with glycol solutions up to 50% in heating, ventilating, and air conditioning (HVAC) systems to provide two-position or modulating functions.

## FEATURES

- **Non-spring Return**
- **Floating and modulating**
- **Space saving, click-on installation – no tool required**
- **Extendable position indicator for easy commissioning**
- **Available with or without cable**
- **Compatible with control ball valves from 1/2 to 1-1/4 inches.**
- **Actuator can be mounted on the valve in any of four positions.**

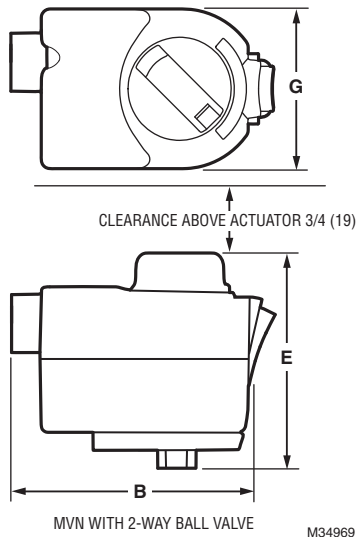


Fig. 3. Dimensions; see Table 5 on page 7.

## SPECIFICATIONS

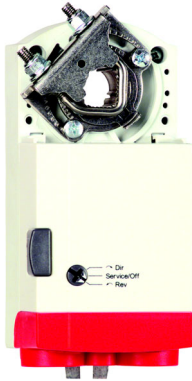
- Actuator Type:** Valve
- Rotational Stroke:** 90° ±3°.
- Fail Safe Mode:** Non-spring return, Fail in place
- Torque:** 27 lb-in. (3 N m).
- External Auxiliary Switches Available:** No
- Supply Voltage:** 24 Vac +20%, -15%, 24 Vdc
- Power Consumption:** 5 VA- Modulating, 1.5 VA - Floating, 6 VA - Fast Acting SPDT
- Environmental Rating:** NEMA2
- Frequency:** 50 Hz; 60 Hz
- Mounting:** Click-on installation – no tool required
- Noise Rating at 1m (Maximum):** 35 dB(A) max at 1 m [50 dB(A) for MVN643].
- Materials:** Plenum rated plastic housing
- Operating Humidity Range (% RH):** 5 to 95% RH, non-condensing
- Ambient Temperature Range:** -4°F to 131°F (-20°C to 55°C)
- Storage Temperature Range:** -40°F to 176°F (-40°C to 80°C)
- Weight:** 0.6 lb. (0.27 kg)
- Dimensions:** See Fig. 1 and Table 5.
- Timing:** 90 sec. (+/-10%) for MVN613 and MVN713; 30 sec. (+/-10%) for MVN643
- Electrical Connections:** Field wiring 18 to 20 AWG to screw terminals, located under the removable access cover.
- Humidity Ratings:** 5% to 95% RH non-condensing.
- Design Life (at Rated Voltage):** 60,000 cycles; 1 cycle = 0°...90°...0°
- Cable Specification:** 18 AWG, Plenum Rated, 300 V, 10 A, 3 ft. length from end of access cover.
- Environmental Protection Ratings:** IP40.
- Approvals:** UL/cUL UL60730

Table 7. Actuators and Accessories

Actuator	Description	Accessory
MVN613A0000	Floating control ball valve actuator	C1- 1 meter cable
MVN643A0000	Fast acting SPDT control ball valve actuator	
MVN713A0000	Modulating control ball valve actuator	

To order actuator with accessories order actuator part number + accessory. For example: MVN613A0000 + C1

## Non-Spring Return Direct Coupled Actuator



## APPLICATION

This non-spring return direct-coupled damper actuator provides modulating and floating/2-position control for: air dampers, air handlers, ventilation flaps, louvers, and reliable control for air damper applications with up to 10 sq. ft./ 44lb.-in. (5 N m) and 20 sq. ft./88 lb.-in. (10 N m) (seal-less damper blades; air friction-dependent).

## FEATURES:

- **Declutch for manual adjustment**
- **Adjustable mechanical end limits**
- **Access cover includes enclosed screw terminal strip (22 to 14 AWG) for electrical connections**
- **Models available with 3 foot 18 AWG color-coded cable**
- **Mountable in any orientation**
- **Function selection switch for selecting modulating or floating/2-position control**

## SPECIFICATIONS

**Actuator Type:** Damper; Valve

**Rotational Stroke:** 95° ±3 degrees

**Fail Safe Mode:** Non-spring return

**Torque:** 44 lb-in. (5 N m)

**External Auxiliary Switches Available:** No

**Environmental Rating:** NEMA2

**Frequency:** 50 Hz; 60 Hz

**Manual operation:** Declutch mechanism

**Mounting:** Direct coupled

**Maximum Noise Rating, Driving (dBA @ 1m):** 35

**Rotation to Open:** By switch

**Rotational Stroke Adjustment:** Dual Integral Adj. Stops (3 degree increments)

**Compatible Damper Shafts:**  
1/4 to 1/2 in. square or 3/8 to 5/8 in. round  
(6 to 13 mm square or 8 to 16 mm round)

**Shaft Adapter Type:** U-bolt clamp

**Supply Voltage:** 24 Vac +20%, -15%, 24 Vdc

**Power Consumption:** 5 VA

**Materials:** Plenum rated plastic housing

**Ingress Protection Rating:** IP54

**Operating Humidity Range (% RH):**  
5 to 95% RH, non-condensing

**Ambient Temperature Range:**  
-5°F to +140°F (-20°C to +60° C)

**Storage Temperature Range:**  
-22°F to +176°F (-30°C to +80°C)

**Weight:** 1 lb (0.45 kg)

**Includes:** Mounting bracket, screws, shaft adapter, water-tight strain-relief cable fittings

**Comments:** Integral 1/2 in. NPSM conduit connection.

### Approvals:

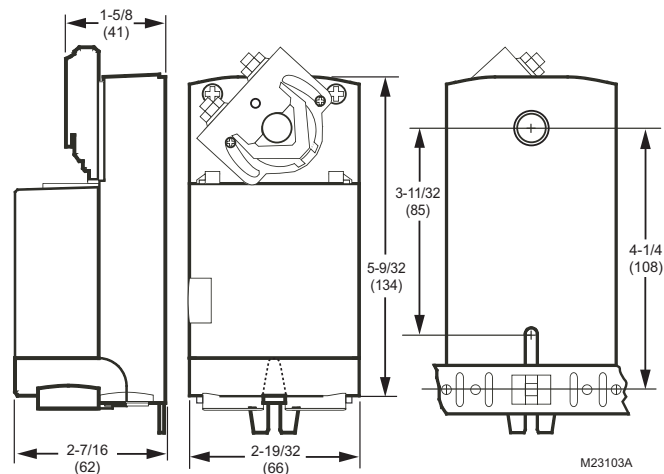
CE: 89/336/ECC, 73/23/EEC

C-Tick: N314

Underwriters Laboratories, Inc.: UL873, Plenum Rated

Canadian Underwriters Laboratories, Inc.:

cUL C22.2 No. 24-93



**Fig. 4. Non-spring return direct coupled actuator dimensions in inches (mm).**

## Spring Return 3 Nm Diamond



## APPLICATION

MS7103 and MS3103 Spring Return Direct Coupled Actuators (DCA) are used within heating, ventilating and air-conditioning (HVAC) systems. They can drive a variety of quarter-turn, final control elements requiring spring return fail-safe operation.

## FEATURES

- **Brushless DC submotor with electronic stall protection**
- **Self-centering shaft adaptor (shaft coupling) for wide range of shaft sizes**
- **Fast test mode**
- **MS7103 models for use with 2-10 Vdc control**
- **MS3103 models for use with Syk-enabled controllers**
- **Models available with two internal end switches**
- **Durable plastic housing with built-in mechanical end limits**
- **Spring return direction field selectable**
- **Shaft position indicator and scale**
- **UL (cUL) listed and CE compliant**
- **Plenum rated actuator and control/power cable**

## SPECIFICATIONS

**Actuator Type:** Damper; Valve

**Rotational Stroke:** 95 ±3 degrees

**Fail Safe Mode:** Spring Return

**Torque:** 27 lb-in. (3 Nm)

**Spring Return Torque:** 27 lb-in (3 Nm)

**Spring Return Direction:** By orientation

**External Auxiliary Switches Available:** No

### Cable Specification:

Power Cable: Plenum Rated, 3 ft (0.914 m) length from end of access cover, 18 AWG

Switch Cable: Appliance Rated, 3 ft (0.914 m) length from end of access cover, 18 AWG

**Ingress Protection Rating:** IP54

**Environmental Rating:** NEMA 2

**Frequency:** 50 Hz; 60 Hz

**Mounting:** Direct Coupled

**Maximum Noise Rating, Driving (dBA @ 1m):** < 40

**Maximum Noise Rating, Spring Return (dBA @ 1m):** < 65

**Rotational Stroke Adjustment:** Mechanically limited  
7.5 degree increments

**Compatible Damper Shafts:** 3/8 to 3/4 in. round or 1/4 to 1/2 in. square (9 to 19 mm round or 6 to 13 mm square)

**Shaft Adapter Type:** U-bolt

**Materials:** Plenum rated plastic housing

**Operating Humidity Range (% RH):** 5 to 95% RH, non-condensing

**Ambient Operating Temperature:** -40 F to +150F (-40 C to +65 C)

**Shipping and Storage Temperature:** -40 F to +150F (-40 C to +65 C)

**Weight:** 1.7 lb (0.78 kg)

### Approvals

UL60730

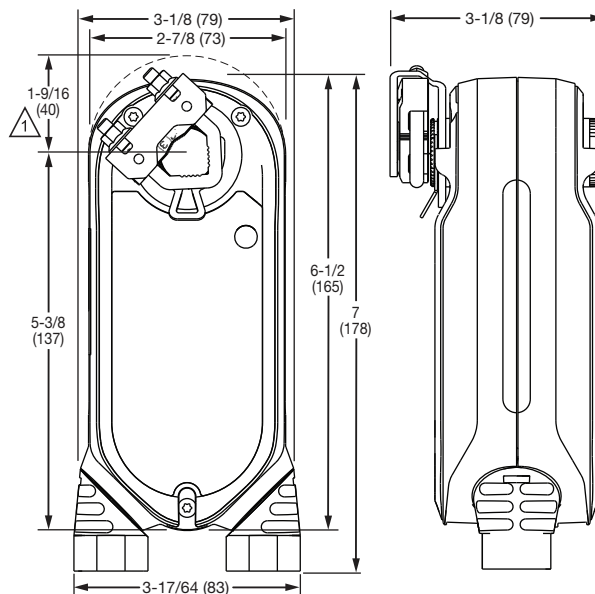
IEC 60730-1 and Part 2-4

UL1097 for Double Insulation

CE Certification Low Voltage Directive 2014/35/EU

CE EMC 2004/108/EC

Switch cables are UL certified only



△ FOR 1/2 INCH SHAFT.

M37351

**Fig. 5. Dimensions in in. (mm).**

## Spring Return Direct Coupled Actuator



## APPLICATION

MS4105, MS7405, MS7505, and MS8105 Spring Return Direct Coupled Actuators (DCA) are used within heating, ventilating, and air-conditioning (HVAC) systems. They can drive a variety of quarter-turn, final control elements requiring spring return fail-safe operation.

## FEATURES

- **Brushless DC submotor with electronic stall protection on all models**
- **Self-centering shaft adaptor (shaft coupling) for wide range of shaft sizes**
- **Access cover includes enclosed screw terminal strip (22 to 14 AWG) for electrical connections.**
- **Models available with 3 foot 18 AWG color-coded cable**
- **Durable plastic housing with built-in mechanical end limits**
- **Spring return direction field selectable**
- **Shaft position indicator and scale**
- **UL (cUL) listed and CE compliant**
- **All models are plenum rated per UL873**

## SPECIFICATIONS

**Actuator Type:** Damper; Valve

**Rotational Stroke:** 95 ±3 degrees

**Fail Safe Mode:** Spring Return

**Torque:** 44 lb-in. (5 N m)

**Spring Return Torque:** 44 lb-in. (5 N m)

**Spring Return Direction:** By orientation

**External Auxiliary Switches Available:** No

**Environmental Rating:** NEMA2

**Frequency:** 50 Hz; 60 Hz

**Mounting:** Direct Coupled

**Maximum Noise Rating, Holding (dBA @ 1m):**  
20 (no audible noise)

**Maximum Noise Rating, Driving (dBA @ 1m):** 50

**Rotation to Open:** By switch

**Rotational Stroke Adjustment:**  
Mechanically limited 5 degree increments

**Compatible Damper Shafts:**  
1/4 to 1/2 in. square or 3/8 to 5/8 in. round  
(6 to 13 mm square or 9 to 16 mm round)

**Shaft Adapter Type:** Self-centering clamping

**Materials:** Plenum rated plastic housing

**Supply Voltage:** 24 Vac +20%, -15%, 24 Vdc

**Power Consumption:** 5 VA

**Operating Humidity Range (% RH):**  
5 to 95% RH, non-condensing

**Ambient Temperature Range:** -40°F to +149°F  
(-40°C to +65°C) for two-position actuators only

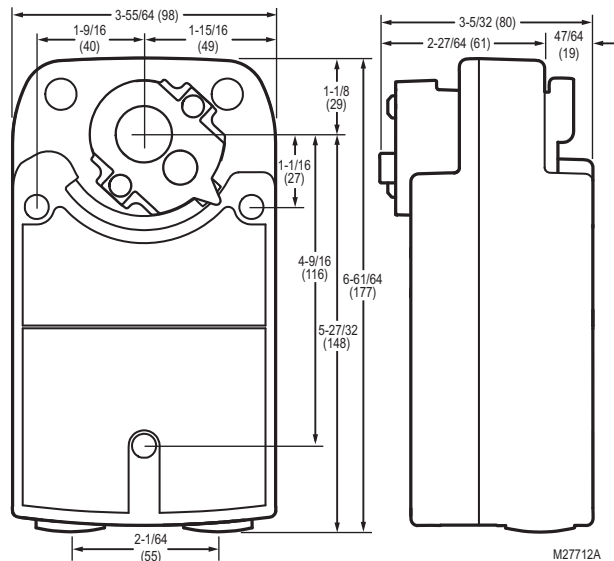
**Storage Temperature Range:**  
-40°F to +150°F (-40°C to +65°C)

**Weight:** 3.5 lb. (1.6 kg)

**Includes:** Mounting bracket, self-centering shaft adapter

### Approvals:

CE: EMC 2004/108/EC; Certification Low Voltage Directive 2006/95/EC; IEC 60730-1 and Part 2-14  
C-Tick: N314  
Underwriters Laboratories, Inc.: UL873  
Canadian Underwriters Laboratories, Inc.: cUL C22.2 No. 24-93



**Fig. 6. Spring return direct coupled actuator dimensions in inches (mm).**

**Table 8. Actuator Accessories and Replacement Parts.**

<b>Part Number</b>	<b>Description</b>	<b>MVN613A0000</b>	<b>MVN643A0000</b>	<b>MVN713A0000</b>	<b>MN Non-Fail-Safe Direct Couple Actuators</b>	<b>MS Fail-Safe Direct Couple Actuators</b>
5112-3R	Weather Enclosure Assembly				x	x
MVNAAA	Replacement Valve Adaptor	x	x	x		
MVNAAL	Replacement Valve Adaptor, Low Profile					
MVNAC7131	Replacement Cable with Terminal 1m, Modulation (RED, BLACK, WHITE)			x		
MVNAC6131	Replacement Cable with Terminal 1m, Floating (RED, BLACK, WHITE)	x	x			
MVNAT3	Replacement Screw type Terminal Block, Pluggable	x	x	x		
5112-11	Replacement actuator bracket				x	x
205860	Minimum position Potentiometer				x	x
32006306-001	Resistor Kit (500 ohm); converts 4-20 mA signal to 2-10 Vdc				x	x
Q7002B1009	Universal Interface Module				x	x
STRN-SCSA	Self-centering Shaft Adapter					x
32000085-001	Strain Relief Fitting (10 pack)				x	
STRN-STRNRLF	Stain Relief Fitting (10 pack)					x

## Application Notes

### IMPORTANT

Valve sizing is important for correct system operation. Undersized valves do not have sufficient capacity at maximum load. Oversized valves do not have sufficient authority over the load in modulating applications.

Oversized valves can cause excessive cycling and the seat and ball can be damaged because of the restricted opening.

### Proper Use

VRN valves are intended for use in chilled water and hot water closed loop applications only, with a temperature range of 35 to 250 °F, and pressures up to 360 psig.

Water should be properly filtered, treated and conditioned for good operating performance, and according to recommendations of the boiler or chiller manufacturers.

The installation of strainers and filters is recommended.

Do not use with manual balancing valves.

### IMPORTANT

The presence of excessive iron oxide (red rust) in the system voids the valve warranty.

### Effective Flow Rate

The built-in differential pressure regulator makes fluid flow through the valve independent of changes in supply pressure, eliminating “hunting” by the control system, even at low coil flow. The pressure regulator virtually eliminates cavitation in the valve, and decouples the control valve from the effects of piping components such as reducers and elbows.

Pressure independent control valves are sized to match design coil flow regardless of coil size. VRN2 valves eliminate the need to balance the system for proper flow, and allow chillers to be operated at design temperature differential for maximum efficiency at every load condition. When used in a system with variable speed pump drives, 3-way valves and coil bypass lines are not required. In new construction, VRN2 valves perform better than reverse return piping designs without the extra materials these systems need. Pressure-independent control requires less flow, enabling use of smaller piping, pumps, and chillers.

### Flow Characteristics

The VRN2 two-way dynamic pressure-regulating control valves have:

- an equal percentage flow characteristic with characterized flow control insert.

## Required Operating Torque

Both Honeywell non-spring return MVN and spring return low torque direct coupled actuators can be utilized with the VRN2 valves. VR valves use a patented seat design that reduces the torque needed from the actuator.

**Table 9. Close-off, Differential Pressure Ratings.**

Valve Type	Valve Size	Close-off Pressure Rating (psi)
2 way	1/2 in., 3/4 in.	100
	1 in., 1-1/4 in., 1-1/2 in.	100

## TYPICAL SPECIFICATIONS

### Valve Actuator

Actuator shall accept analog modulating [(0)2-10 Vdc], floating (tri-state), or two-position signal as indicated in the control sequence. Actuators shall be manufactured by Honeywell. Actuator shall provide minimum torque required for full valve shutoff position. Wiring terminals shall be provided for installation to control signal and power wiring.

Actuator shall be available with housing suitable for outdoor installation.

Accessories Identification tags shall be available for all valves.

### Pressure Independent Valve

Valve housing shall consist of forged brass rated at no less than 360 psi at 250°F. Standard valve ball shall consist of chemically nickel-plated brass. Manufacturer shall be able to provide optional 316 stainless steel ball and stem. The valve shall have an integral differential pressure regulator to maintain constant pressure drop across valve seat to decouple valve flow from system pressure changes. Flow control accuracy shall be +/-5% or better. Regulator will be constructed from 316 stainless steel with a rolling diaphragm and operate under positive pressure. Regulator shall be located above axis of pipe with 1/4" ISO test port fittings to allow pressure measurement and venting.

Valve stem assembly shall be of a pack-less design and be field-replaceable without removing the valve body from the piping. Teflon™ seals shall hold the stem in alignment, and protect the O-ring from system temperature fluctuations. Stem O-ring shall be made of peroxide-cured EPDM and be isolated from system treatment chemicals by a reservoir of silicon grease. Valve shall have a blow-out proof stem with minimum 600 psi rating.

# INSTALLATION

## When installing this product...

1. Read these instructions carefully. Failure to follow them could damage the product or cause a hazardous condition.
2. Check ratings given in instructions and on the product to ensure the product is suitable for your application.
3. Installer must be a trained, experienced service technician.
4. After installation is complete, check out product operation as provided in these instructions.

## Preparation



### CAUTION

#### Equipment Damage Hazard

Foreign particles like dirt and metal chips can damage the ball seals.

For trouble-free operation of the product, good installation practice must include initial system flushing, and chemical water treatment. Clean the lines upstream of particles larger than 1/16 inch diameter (welding slag, pipe scale, sand and other suspended particulate). Use of a 50 micron (or finer) system side stream filter is suggested. Remove all filters before flushing.

Do not use boiler additives, solder flux and wetted materials which are petroleum based or contain mineral oil, hydrocarbons, or ethylene glycol acetate. Compounds which can be used, with minimum 50% water dilution, are diethylene glycol, ethylene glycol, and propylene glycol (antifreeze solutions).

If installing these valves in an addition to, or retrofitting an existing building, do not assume that the fluid in the existing piping meets these criteria.

## Mechanical Installation

### IMPORTANT:

Hold valve with pipe wrench by hexagonal fitting ONLY. Do NOT handle the valve body with the pipe wrench; product damage may result.

The valves are tapped in NPT and should be sealed with an approved pipe sealant. Torque should not exceed 75 lb-ft.

Refer to actuator literature for actuator dimensions.

1. Clean the lines upstream of particles larger than 1/16 in. diameter (welding slag, pipe scale and other contaminants).
2. Proceed with installation once the system specifics (expansion/contraction of the system and its medium as well as operating pressures) are within tolerances.

3. Eliminate air from system.
4. Two-way valves are marked to show flow direction.

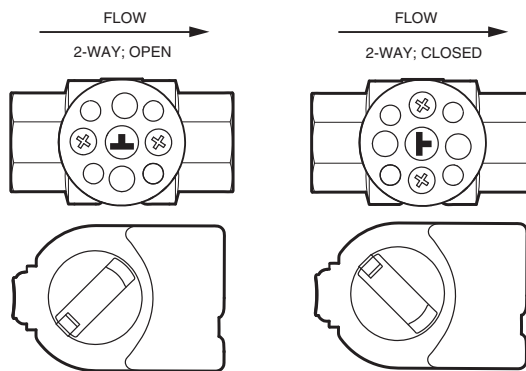
### IMPORTANT

Flow arrows must point in the direction of the flow for proper operation.

5. Stem rotation:
  - a. For two-way valves:
    - (1) Clockwise to close.
    - (2) Counterclockwise to open.

NOTE: After valves have been installed in the piping, the installer can determine the ball orientation within the valve from the notches in the top of the valve stem. For two-way valves, the lengthwise direction of the notch indicates the flow through the ball (i.e. when the notch is parallel to the axis of the valve between A and B ports, the ball will allow flow through the valve).

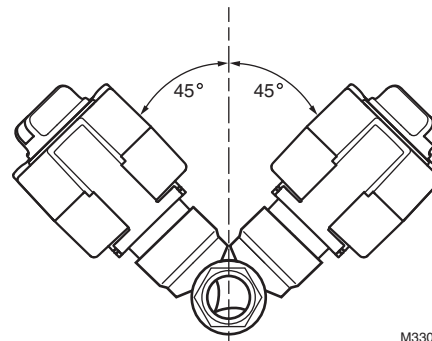
6. Valve must be mounted with the actuator/bracket above the valve body. Do not install the valve with the stem below horizontal or upside down. (See Fig. 8 – 10.)



NOTES: FOR 2-WAY VALVES TO MOUNT ACTUATOR ON OPEN VALVE, TURN ACTUATOR FULLY COUNTER CLOCKWISE AS SHOWN. FOR 2-WAY VALVES TO MOUNT ACTUATOR ON CLOSED VALVE, TURN ACTUATOR FULLY CLOCKWISE AS SHOWN.

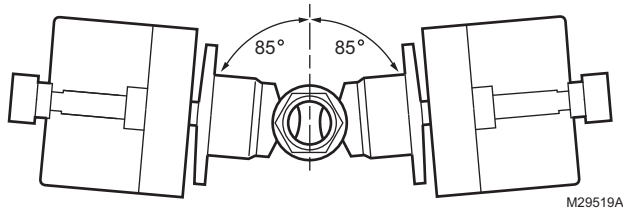
M34979

Fig. 7. Orientation of valve.

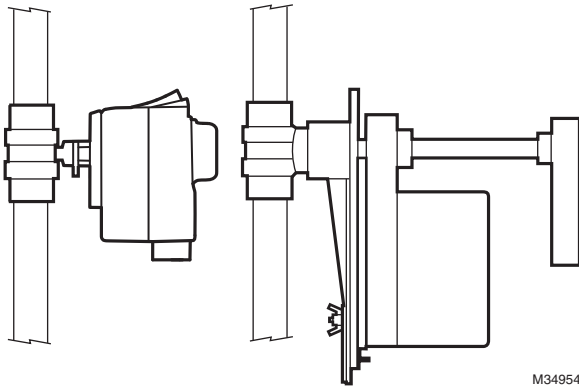


M33091

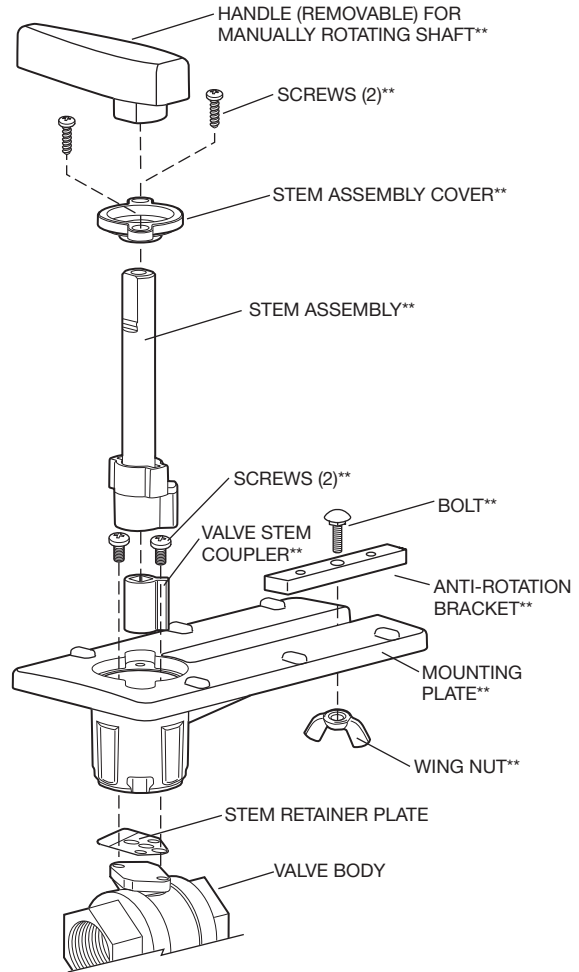
Fig. 8. Acceptable valve angle from vertical for MVN actuators.



**Fig. 9. Acceptable valve angle from vertical for MN and MS actuators.**



**Fig. 10. Vertical valve installation.**



\*\* INCLUDED IN REPLACEMENT KIT (PART NO. 5112-11).

M29526B

**Fig. 11. Actuator mounting plate adjustment.**

## Mounting Plate Adjustment

NOTE: See Fig. 11 for valve exploded view.

The Actuator Mounting Plate can be rotated to a different position for installation in confined spaces. This is accomplished as follows:

1. Remove the handle from the shaft and set it aside.
2. Remove the two screws that hold the stem assembly to the mounting plate and set them aside.
3. Remove and set aside the stem assembly.
4. Remove and set aside the two screws that attach the mounting plate to the valve.
5. Remove and set aside hold-down ring from mounting plate.
6. Rotate mounting plate around valve top to the desired position.

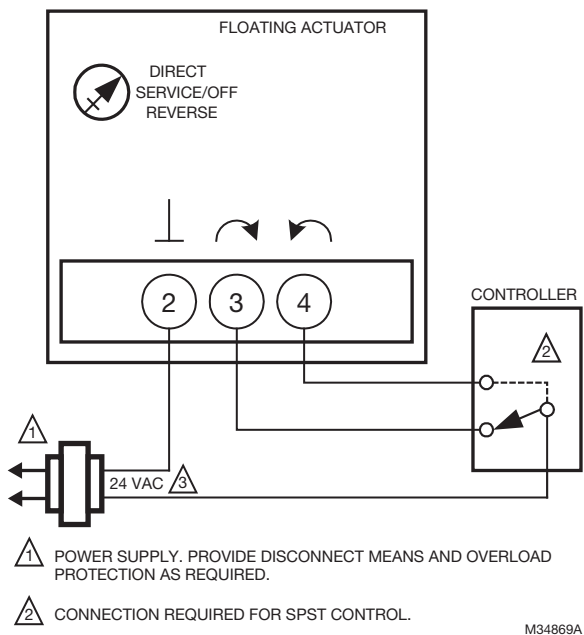
NOTE: Take note of the screw hole positions on the valve. They limit the mounting plate positions.

7. Lower ring down to valve body and engage it in the new position relative to the mounting plate.
8. Tighten screws to valve body securing the mounting plate.
9. Reattach the stem assembly to the mounting plate.
10. If desired, replace the handle on the shaft.

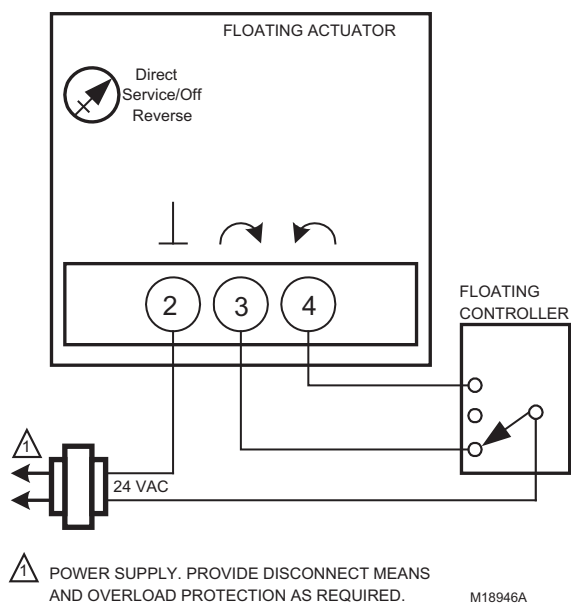
## Electrical Installation

1. If necessary, remove actuator wiring cover.
2. Wire actuator using Figures 12 through 35 for the application required.
3. Replace cover.

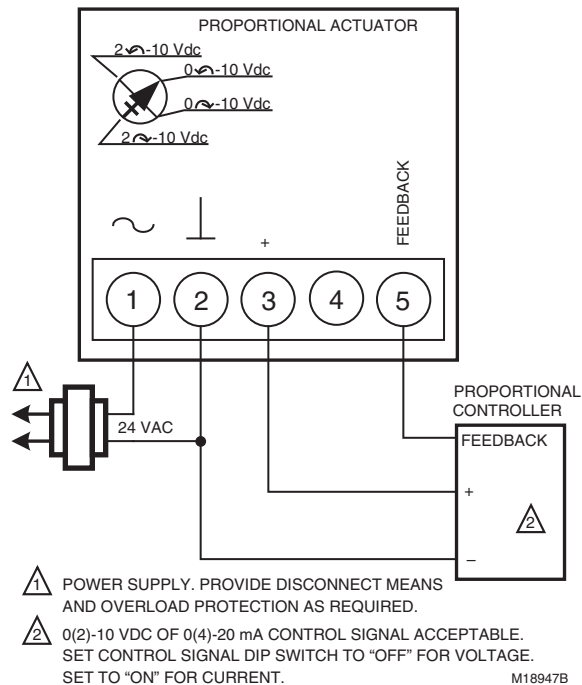
## Wiring



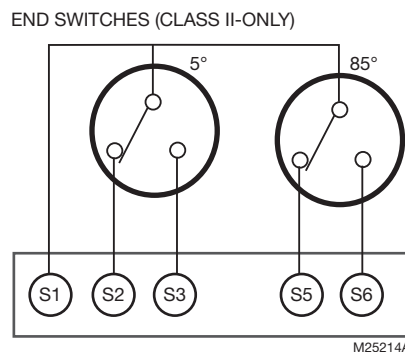
**Fig. 12. MN6105 with On/Off SPDT Control.**



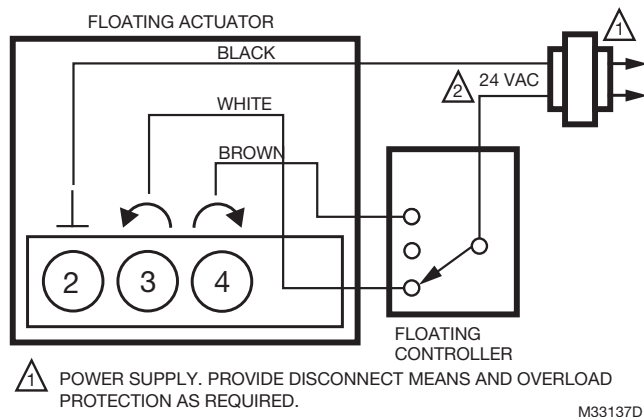
**Fig. 13. MN6105 with Floating Control.**



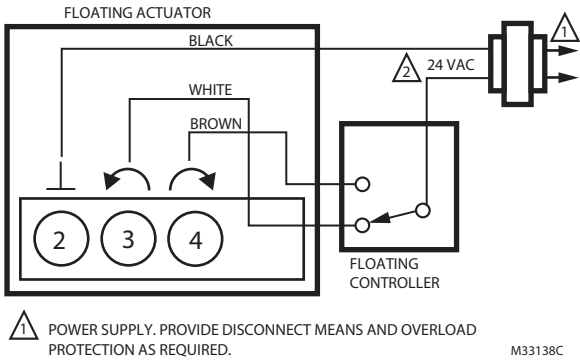
**Fig. 14. MN7505 with 0(2)-10 Vdc Control.**



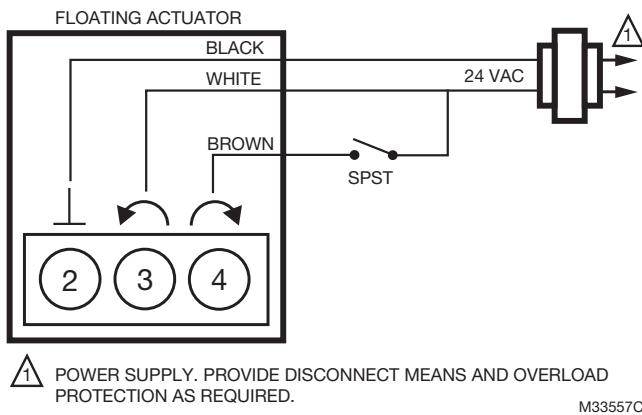
**Fig. 15. Wiring for MN6105 and MN7505 models with aux./end switches.**



**Fig. 16. MVN613 with Floating Control.**

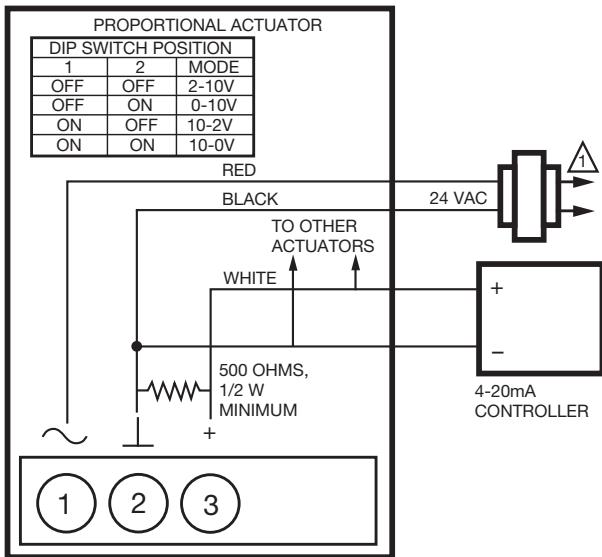


**Fig. 17. MVN613 or MVN643 with Two Position SPDT Control.**

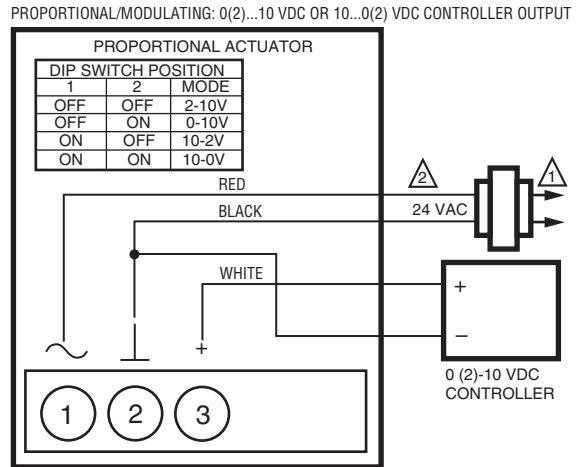


**Fig. 18. MVN643 with Two Position SPST Control.**

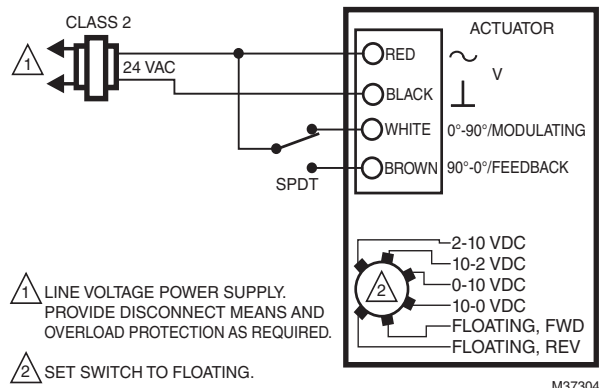
PROPORTIONAL/MODULATING: 4-20mA CONTROLLER OUTPUT WITH 500Ω SERIES RESISTOR



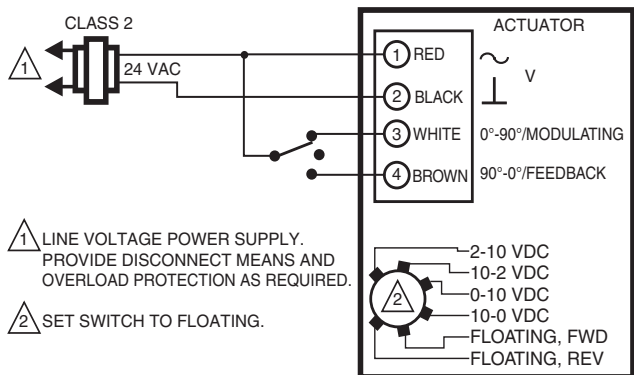
**Fig. 19. MVN713 with 4-20mA Control.**



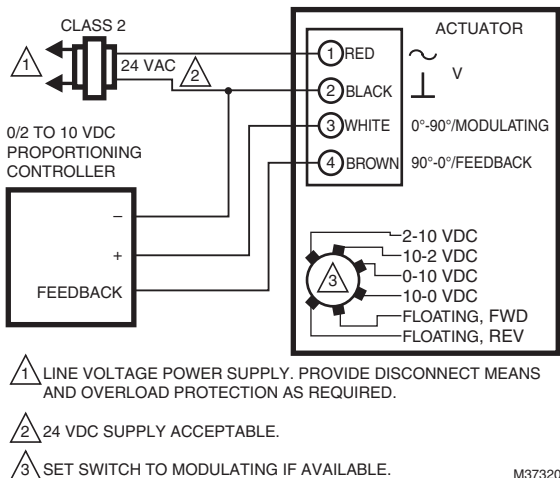
**Fig. 20. MVN713 with 0(2)-10 Vdc Control.**



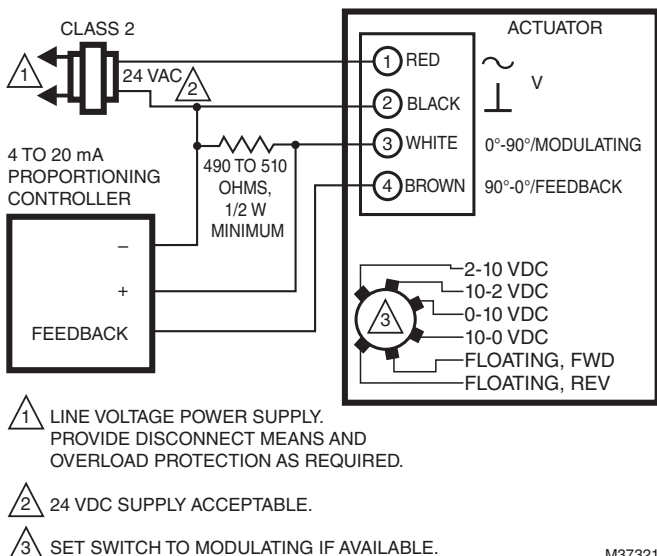
**Fig. 21. MS7505 with Two Position SPDT Control.**



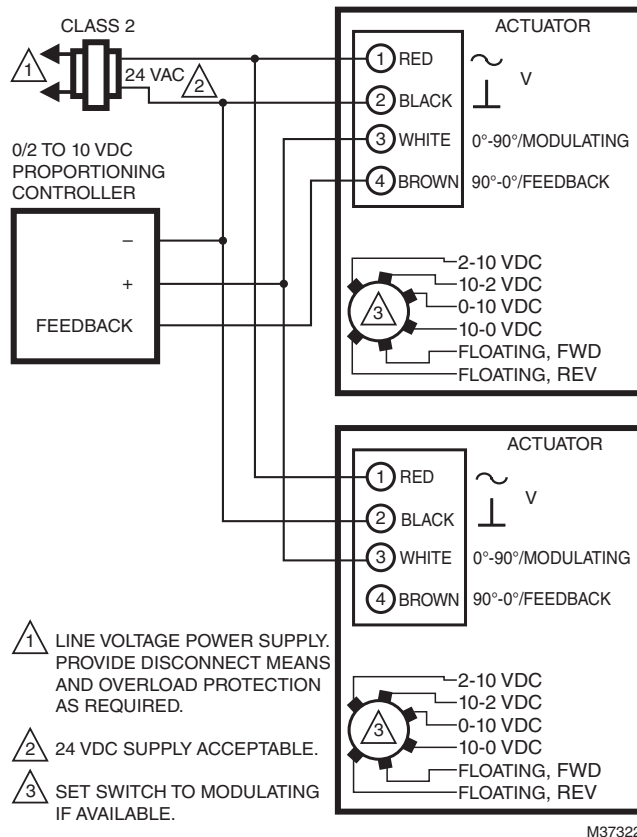
**Fig. 22. MS7505 with Floating Control.**



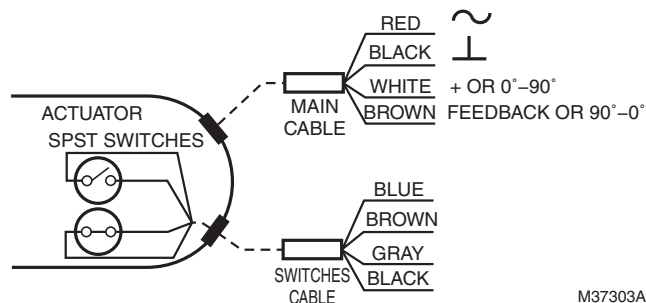
**Fig. 23. MS7103 with 2-10 Vdc Control (MS7503 shown, ignore selection switch).**



**Fig. 24. MS7103 with 4-20 mA Control (MS7503 shown, ignore selection switch).**



**Fig. 25. MS7103 with 2-10 Vdc Control using two actuators (MS7503 shown, ignore selection switch).**



**Fig. 26. Wiring for MS7103 and MS3103 Auxiliary Switches. Gray/Black = Normally Open. Closed in range 80 degrees to Fully Open. Blue/Brown = Normally Closed. Open in range 10 degrees to Fully Open.**

VRN PRESSURE INDEPENDENT CONTROL VALVES AND ACTUATORS

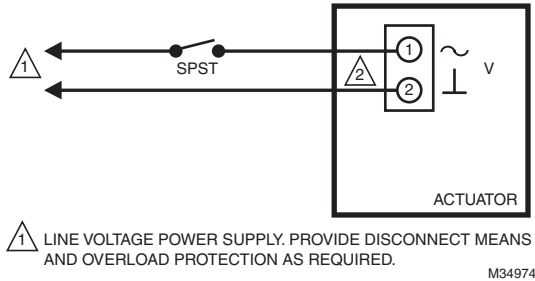
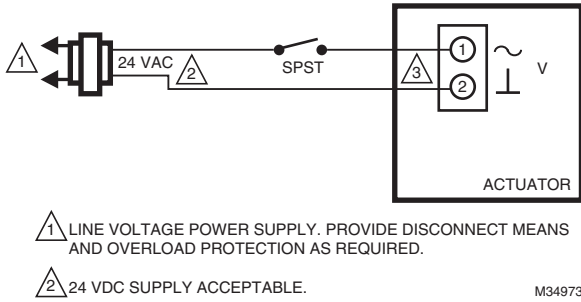


Fig. 27. MS8105 with Two Position SPDT Control.

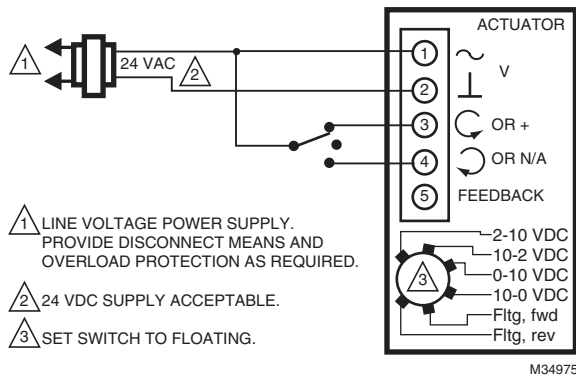


Fig. 28. MS7505 with Floating Control.

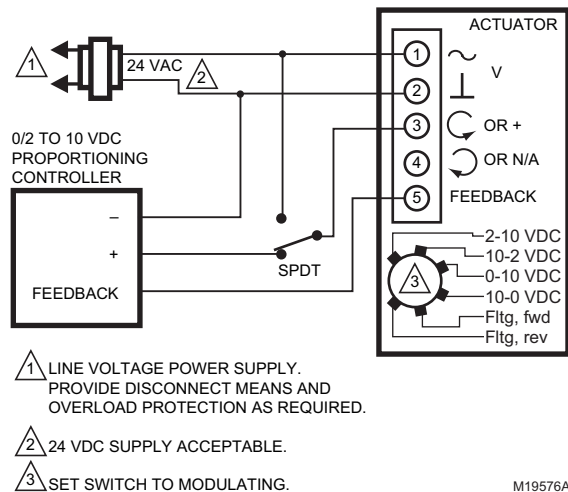


Fig. 29. MS7505 with override to full open.

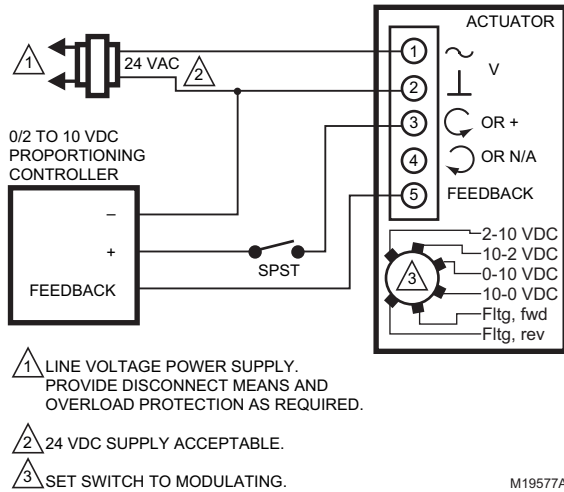


Fig. 30. MS7505 with override to full closed.

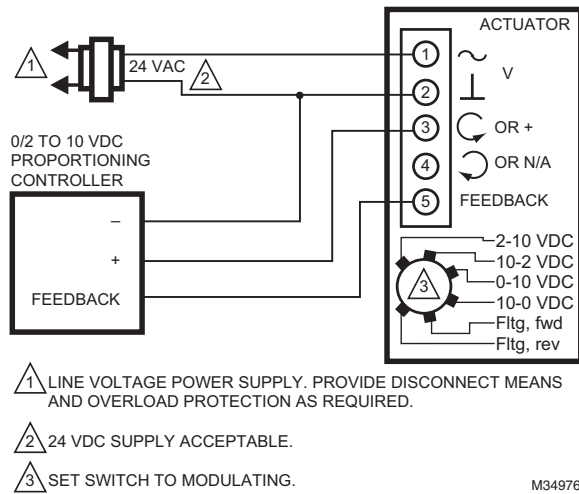


Fig. 31. MS7505 with 0(2)-10 Vdc Controllers.

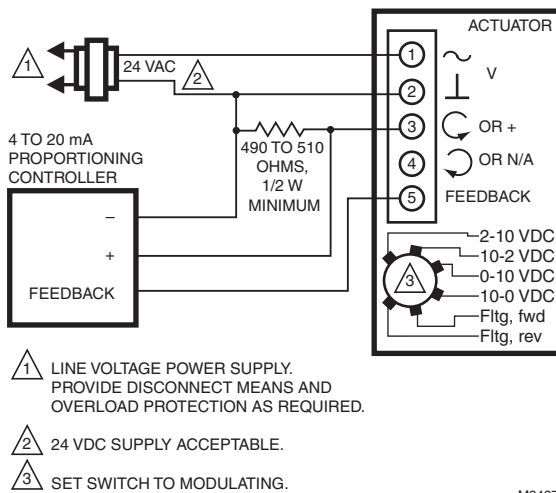
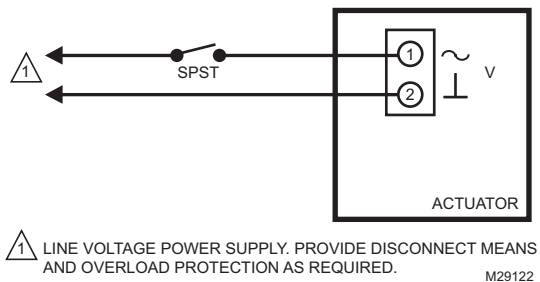
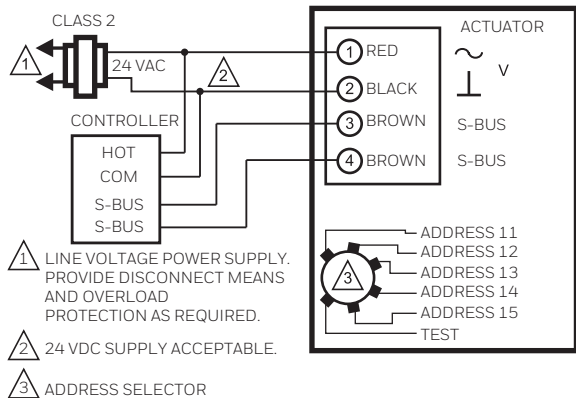


Fig. 32. MS7505 with 4-20mA Controllers.

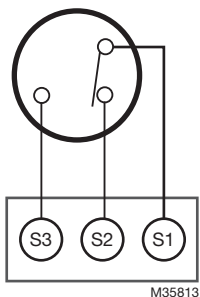


**Fig. 33. MS4105 with 120 Vac Two Position SPDT control.**



**Fig. 36. MS3103 with Sylk Bus control.**

NOTE: All identified parts except for the valve body and aluminum valve stem coupler are included in Replacement Kit (part no. 5112-11).

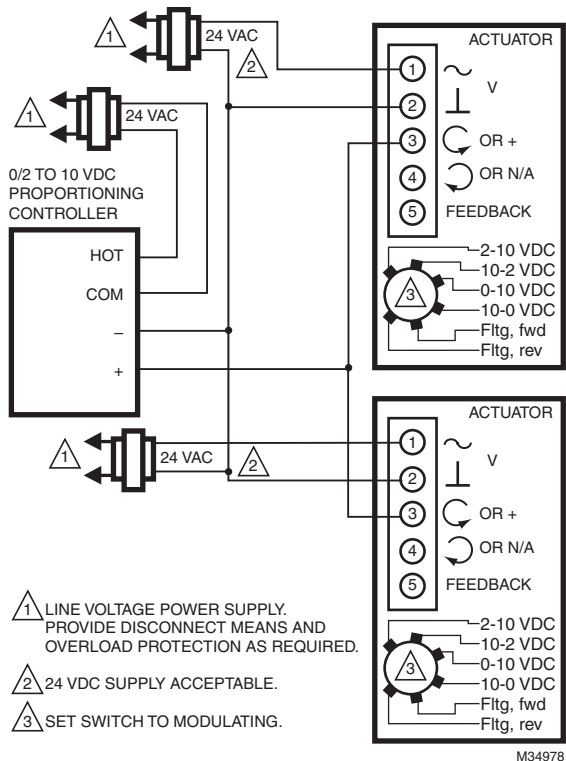


**Fig. 34. Wiring for MS4105, MS7505, and MS8105 models with aux./end switches.**

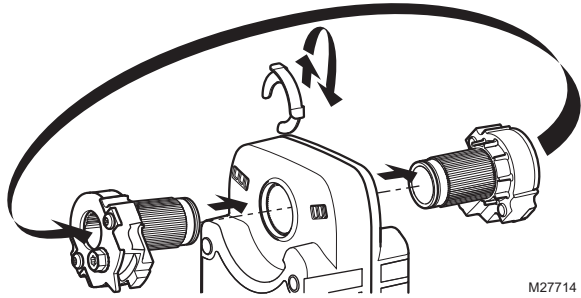
## OPERATION AND CHECKOUT

Once both the mechanical and electrical installations are complete:

1. Cycle the actuator to verify that the direction of rotation suits the control sequence.
2. If the rotation direction is incorrect:
  - a. For 2-position and Sylk-enabled spring return actuators: Remove, flip over, and replace actuator on the bracket.
  - b. For floating control actuators: Reverse two control signal wires (CW/CCW), or change position of selector switch.
  - c. For analog control actuators either:
    - (1) Change setting of reverse/direct-acting switch, or
    - (2) Remount actuator on the bracket.
3. If the control scheme requires fail-safe operation, ensure that, upon removal of power, the fail position coincides with the control sequence.
4. Spring return actuators are factory-configured for normally-closed, fail-safe operation on power loss. To change this action to normally-open, remove and reinstall the actuator in the opposite orientation as follows:
  - a. Loosen the shaft coupling bolt using a 10 mm wrench.
  - b. Loosen all other mounting bolts connecting the actuator to the mounting bracket, and set aside.
  - c. Remove the actuator from the valve shaft.
  - d. Move the Self-Centering Shaft Adaptor to the opposite side of the actuator, as displayed in Fig. 37.



**Fig. 35. MS7505 with 0(2)-10 Vdc controller operating multiple actuators.**



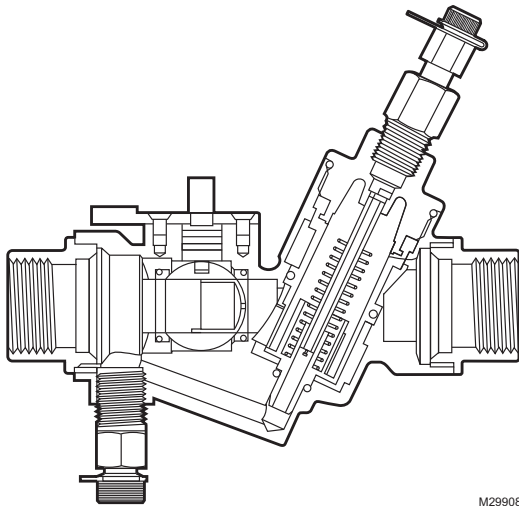
M27714

**Fig. 37. Change actuator to normally open.**

- (1) Remove the retainer clip from the Self-Centering Shaft Adapter and set it aside for later use.
- (2) Remove SCSA from actuator.
- (3) Reinstall SCSA on the opposite side of the actuator, aligning it based on the stroke labeling.
- (4) Replace the retainer clip on the shaft coupling using the groove of the coupling.
- e. Reconnect the actuator to the valve mounting bracket by replacing the screws previously removed (step b).
- f. Tighten the shaft coupling bolt using a 10 mm wrench or socket.

## Operation

$P_{IN}$  changes constantly in a multi-zone system as other valves open and close, changing system flow and head pressure according to the characteristics of the supply pump curve. Reaction of the mechanical pressure regulator is instantaneous, eliminating changes in room temperature due to changes in fluid flow, and reducing the need for the control system to constantly operate the control portion of the valve to correct for the non-load related temperature changes that occur in a system with standard control valves.

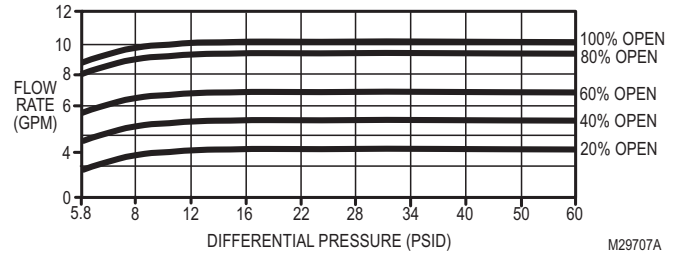


M29908A

**Fig. 38. VRN2 cross section showing fitting, control ball, and pressure regulator.**

At full flow in a 2-position control application, a VRN2 behaves as a flow limiter.

The pressure regulator takes a minimum pressure to operate, and has a maximum differential regulation capability. See Fig. 39. The high pressure drop across a VRN2 Valve is comparable to the pressure drop across a control valve and balancing valve in a conventional system design.



M29707A

**Fig. 39. Pressure regulation, large body models.**

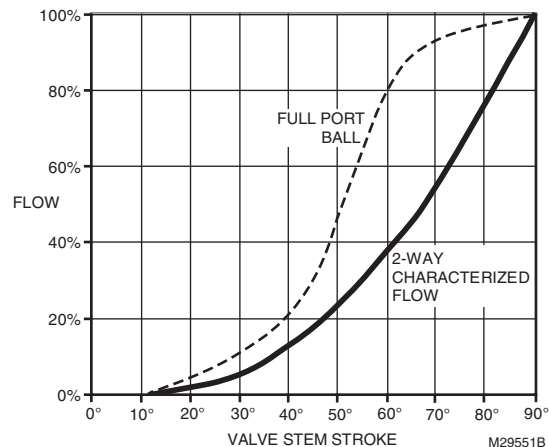
## SETTINGS AND ADJUSTMENTS

At the full open position, VRN2 valves will maintain flow in the loop. Flow rates are listed in the Specification Data form 62-3115EFS. Under steady state operation, the control system will only require the valve to open enough to satisfy load conditions. During morning recovery from night setback, the controller will usually command the valve to 100%. For optimum performance, choose only the next larger valve size needed to satisfy design load. Do not oversize valves—reduced rangeability and may result in less accurate temperature control.

Ball valves close between 10 and 15% of stroke, to ensure full seal engagement. If desired, modulating actuators can be set to 0-10 V response so that 2 V of a 2-10 V control signal more closely corresponds to minimum flow. The valve will still close with signal loss.

If desired, maximum flow may be trimmed to a lesser value in one of two ways:

1. With modulating actuator, limit span of control voltage issued by the building automation controller. Valves with flow control inserts have an equal percentage flow characteristic (See Fig. 40). Each 10% reduction in maximum control voltage will result in a 10% reduction in flow.



M29551B

**Fig. 40. Typical flow characteristics.**

- To mechanically limit stroke, set DCA to full open position. Loosen shaft coupling and rotate valve shaft to desired maximum flow position, as confirmed by pressure measurement across coil, using coil manufacturer's data. Retighten shaft coupling. Use Fig. 40 as a guide to setting actuator stroke.

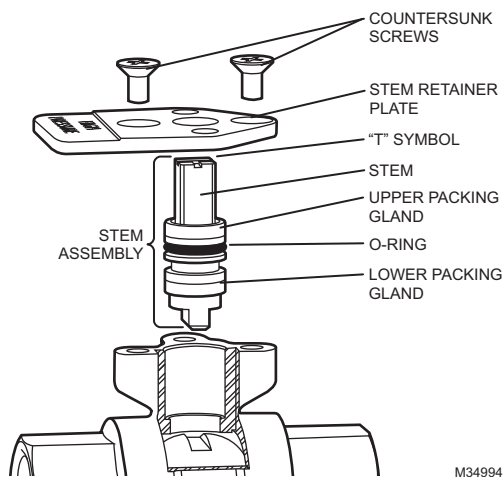
If using mechanical adjustment technique with MN/MS7505 modulating actuators, the stroke auto-adaption feature will automatically scale the 2–10 Vdc signal to the mechanical rotation of the ball. See actuator literature for details.

Coil flow can be confirmed by reading pressures at the coil inlet and coil outlet (not across control valve as with conventional balancing—this pressure drop will be constant), and using the manufacturer's data to calculate flow.

Note that the pressure regulator in this valve guarantees that the flow through the coil will not be affected by upstream changes in pressure. Unlike conventional balancing valves, it is not necessary to reconfirm coil flow after adjusting other valves. Any overflow during morning recovery due to oversized pressure regulated valves will not affect other valves in the system, provided pumps are capable of required flow.

## Service and Repair

The valve stem can be replaced in-line, if necessary. See Fig. 41.



**Fig. 41. Replacing the valve stem in-line.**

Follow steps 1 to 6 of “Mounting Plate Adjustment” on page 16, then:

- If the lower packing gland is stuck, remove it with gland removal tool or rubber-tipped dental tool.



## CAUTION

**Avoid scratching the inside of the valve neck.**  
This may cause a leak when re-assembled.

- Carefully remove any fouling or corrosion from inside of valve.
- Align arrow with short leg of “T” symbol on new stem assembly.

NOTE: “T” symbol will vary.

- Insert the new stem assembly. Be sure to line up the stem key with the ball slot.
- Fasten stem retainer high pressure plate to the valve using the new countersunk screws. Then fasten the mounting plate to the valve.
- Repressurize valve and confirm stem does not leak before proceeding.
- Slide the sub shaft over the stem with the tab oriented as shown in Fig. 41.
- Replace the thermal break, shaft, and shaft cover. If shaft has come loose from thermal break, push firmly on end of shaft until blade in shaft snaps into thermal break.
- Replace actuator and secure it to shaft and mounting plate.
- Snap handle onto top of shaft.

Any other service to valve such as seat seal replacement requires removal of valve from piping.

By using this Honeywell literature, you agree that Honeywell will have no liability for any damages arising out of your use or modification to, the literature. You will defend and indemnify Honeywell, its affiliates and subsidiaries, from and against any liability, cost, or damages, including attorneys' fees, arising out of, or resulting from, any modification to the literature by you.

**Honeywell Building Technologies**

In the U.S.:

Honeywell

715 Peachtree Street NE

Atlanta, GA 30308

[customer.honeywell.com](http://customer.honeywell.com)

**Honeywell**

® U.S. Registered Trademark  
© 2020 Honeywell International Inc.  
38-00032-02 M.S. Rev. 01-20  
Printed in United States