

Honeywell

THE VR8300 CONTINUOUS PILOT DUAL AUTOMATIC VALVE COMBINATION GAS CONTROLS ARE USED IN GAS-FIRED, STANDING PILOT APPLIANCES. THEY INCLUDE SAFETY SHUTOFF, A MANUAL VALVE, TWO AUTOMATIC OPERATORS, AND A PRESSURE REGULATOR.

- For use with 24 Vac heating appliances that burn natural or liquefied petroleum (LP) gas.
- Capacity rated up to 200 feet³/hour at 1 inch wc pressure drop [5.7 meters³/hour at 0.25 kPa]. Maximum capacity rated up to 300 feet³/hour [8.5 meters³/hour]. Minimum capacity rated at 30 feet³/hour [0.8 meters³/hour].
- Solenoid operated first automatic valve opens on thermostat call for heat and closes when call for heat ends.
- Diaphragm-operated second automatic valve opens under control of the regulator and closes if gas or power supply is interrupted.
- Three-position manual gas control knob has ON, OFF and PILOT positions.
- Separate reset button must be held down to permit gas flow while lighting pilot, can be pushed down only in PILOT position.
- All adjustments, wiring connections and pilot outlet are accessible from the top of the control.
- Compact size.
- Straight-through body pattern; right angle adapters available for inlet and outlet.
- Available in 1/2 and 3/4 inch inlet and outlet. 1/2 and 3/4 inch straight and angle flanges available.
- Adjustable servo regulator effectively maintains almost constant gas output pressure under wide fluctuations in gas supply pressure.
- Inlet screen included.
- Pilot filter included.
- Wiring terminal block color-coded beige to identify standing pilot models.
- May be installed at any angle between 0 and 90 degrees from the upright position, including vertically.
- 1/4 inch male quick-connect terminals for electrical connections.
- 0° F to +175° F [-18° C to +79° C] temperature range standard; -40° F to +175° F [-40° C to +79° C] available.
- Inlet and outlet pressure taps included; both taps accessible from top of control.
- Standard-, slow-, and step-opening models available.
- Natural/LP gas conversion kits available for standard and slow-opening models.

CONTINUOUS PILOT DUAL AUTOMATIC VALVE COMBINATION GAS CONTROLS

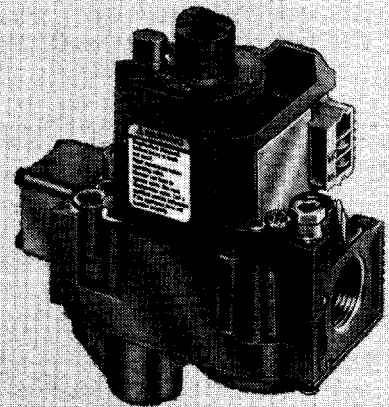

VR8300

SPECIFICATIONS

IMPORTANT

THE SPECIFICATIONS GIVEN IN THIS PUBLICATION DO NOT INCLUDE NORMAL MANUFACTURING TOLERANCES. THEREFORE, THIS UNIT MAY NOT MATCH THE LISTED SPECIFICATIONS EXACTLY. ALSO, THIS PRODUCT IS TESTED AND CALIBRATED UNDER CLOSELY CONTROLLED CONDITIONS, AND SOME MINOR DIFFERENCES IN PERFORMANCE CAN BE EXPECTED IF THOSE CONDITIONS ARE CHANGED.

SUPER TRADELINE MODELS

SUPER TRADELINE controls offer features not available on TRADELINE or standard models, and are designed to replace a wide range of Honeywell and competitive controls.

SUPER TRADELINE Models Available:
VR8300A Combination Gas Control
3/4 inch inlet x 3/4 inch outlet

Additional Features:

- 393691 Natural to LP gas conversion kit
- Two 1/2 x 3/4 inch reducer bushings
- One Q340 Thermocouple (36 inch lead length)
- SUPER TRADELINE packaging with cross reference label and special instruction sheet.

TRADELINE MODELS

TRADELINE controls offer features not available on standard models and are designed to replace a wide range of Honeywell and competitive controls.

TRADELINE Models Available:
VR8300A Combination Gas Control
VR8300C Combination Gas Control

Additional Features:

- 393691 Natural to LP gas conversion kit (not available for VR8300C models)
- For 1/2 x 3/4 inch models, one 1/2 x 3/4 inch reducer bushings
- For 3/4 x 3/4 inch models, two 1/2 x 3/4 inch reducer bushings
- TRADELINE packaging with cross reference label and special instruction sheet

STANDARD MODELS

MODELS: VR8300 Continuous Pilot Dual Automatic Valve Combination Gas Controls. For use in standing pilot appliances. See Table 1 for model specifications.

SUPPLY VOLTAGE: 24 Vac, 50/60 Hz.

POWER UNIT:

Reset current: 300 mA maximum.
Drop-out current: 70mA minimum.

THERMOCOUPLE:

Nominal output: 30 mV (0.018 ohms).
Open Circuit Turndown Voltage: 2mV.

ELECTRICAL CONNECTIONS (2): 1/4 inch male quick-connects. Two convenience terminals on top of control (optional). Terminal block color-coded beige.

THERMOSTAT HEAT ANTICIPATOR SETTING: 0.7 A.

ORDERING INFORMATION

WHEN PURCHASING REPLACEMENT AND MODERNIZATION PRODUCTS FROM YOUR WHOLESALER OR YOUR DISTRIBUTOR, REFER TO THE PRICE SHEETS FOR COMPLETE ORDERING NUMBER, OR SPECIFY—

1. Order number.
2. Natural or LP gas.
3. Step pressure on VR8300C,P.
4. Convenience terminals, if desired.
5. Accessories, if desired.
6. Order separately: pilot burner, thermocouple, transformer, limit controller, and thermostat or controller as required.

IF YOU HAVE ADDITIONAL QUESTIONS, NEED FURTHER INFORMATION, OR WOULD LIKE TO COMMENT ON OUR PRODUCTS OR SERVICES, PLEASE WRITE OR PHONE:

1. YOUR LOCAL HONEYWELL RESIDENTIAL AND BUILDING CONTROLS DIVISION SALES OFFICE (CHECK WHITE PAGES OF YOUR PHONE DIRECTORY).
2. RESIDENTIAL AND BUILDING CONTROLS DIVISION CUSTOMER SATISFACTION
HONEYWELL INC., 1885 DOUGLAS DRIVE NORTH
GOLDEN VALLEY, MINNESOTA 55422-4386 (612) 542-7500

IN CANADA—HONEYWELL LIMITED/HONEYWELL LIMITEE, 740 ELLESMERE ROAD, SCARBOROUGH, ONTARIO M1P 2V9. INTERNATIONAL SALES AND SERVICE OFFICES IN ALL PRINCIPAL CITIES OF THE WORLD.

TABLE 1—MODEL SPECIFICATIONS.

MODEL NO. SUFFIX LETTER	OPENING CHARACTERISTIC	TYPE OF GAS	STANDARD FACTORY REGULATOR SETTINGS		RANGES OF OPTIONAL FACTORY REGULATOR SETTINGS		RANGES OF FIELD ADJUSTMENT	
			in. wc	kPa	in. wc	kPa	in. wc	kPa
A,M	Standard-opening	Natural	3.5	0.9	3 to 5	0.7 to 1.2	3 to 5	0.7 to 1.2
		LP	10.0	2.5	8 to 12	2 to 3	8 to 12	2 to 3
C,P	Step-opening	Natural	Step—0.7, 0.9, 1.2 or 1.7, as ordered ^a Full Rate—3.5	Step—0.17, 0.22, 0.30 or 0.48, as ordered ^a Full Rate—0.9	Step—0.7, 0.9, 1.2 or 1.7, as ordered ^a Full Rate—3 to 5	Step—0.17, 0.22, 0.30 or 0.48, as ordered ^a Full Rate—0.7 to 1.2	Step—none; Full Rate—3 to 5	Step—none; Full Rate—0.7 to 1.2
		LP	Step—1.4, 2.5, 4.0 or 5.5, as ordered ^a Full Rate—10	Step—0.35, 0.62, 0.99 or 1.37, as ordered ^a Full Rate—2.5	Step—1.4, 2.5, 4.0 or 5.5, as ordered ^a Full Rate—8 to 12	Step—0.35, 0.62, 0.99 or 1.37, as ordered ^a Full Rate—2 to 3	Step—none; Full Rate—8 to 12	Step—none; Full Rate—2 to 3
H	Slow-opening	Natural	3.5	0.9	3 to 5	0.7 to 1.2	3 to 5	0.7 to 1.2
		LP	10.0	2.5	8 to 12	2 to 3	8 to 12	2 to 3

^aStep pressure not adjustable.

CAPACITY:

SIZE (INLET X OUTLET)	CAPACITY AT 1 INCH WC PRESSURE DROP ^a	MINIMUM REGULATED CAPACITY	MAXIMUM REGULATED CAPACITY
1/2 X 1/2	180 feet ³ /hour [5.1 meter ³ /hour]	30 feet ³ /hour [0.8 meter ³ /hour]	225 feet ³ /hour [6.4 meter ³ /hour]
1/2 X 3/4	190 feet ³ /hour [5.4 meter ³ /hour]	30 feet ³ /hour [0.8 meter ³ /hour]	290 feet ³ /hour [8.2 meter ³ /hour]
3/4 X 3/4	200 feet ³ /hour [5.7 meter ³ /hour]	30 feet ³ /hour [0.8 meter ³ /hour]	300 feet ³ /hour [8.5 meter ³ /hour]

^aCapacity based on 1000 btu/feet³, 0.64 specific gravity natural gas at 1 inch wc pressure drop [37.3 MJ/meter³, 0.64 specific gravity natural gas at 0.25 kPa pressure drop.

TYPE OF GAS: Separate models available for natural or LP gas. Natural/LP gas conversion kits are available for standard- and slow-opening models. See Accessories.

Use conversion factors in Table 2 to convert capacities for other gasses.

TABLE 2—GAS CAPACITY CONVERSION FACTORS.

GAS	SPECIFIC GRAVITY	MULTIPLY LISTED CAPACITY BY
Manufactured	0.60	0.516
Mixed	0.70	0.765
Propane	1.53	1.62

BODY PATTERN: Straight-through body pattern.

INLET X OUTLET SIZES AVAILABLE: 1/2 x 1/2 inch, 1/2 x 3/4 inch, and 3/4 x 3/4 inch with inlet flange.

ADAPTERS: Adapters available for 1/2 and 3/4 inch straight and angle connections. Refer to Table 3.

NOTE: Flange Kits include one flange with attached O-ring and four mounting screws.

PILOT GAS OUTLET: Compression fitting for 1/4 inch OD tubing.

TABLE 3—FLANGE PART NUMBERS.

INLET/OUTLET PIPE SIZE	FLANGE TYPE	PART NUMBER	
		WITHOUT HEX WRENCH	WITH HEX WRENCH
1/2 inch NPT	Straight	394599-6	393690-16
	Elbow	394599-3	393690-13
3/4 inch NPT	Straight	394599-4	393690-14
	Elbow	394599-5	393690-15

PRESSURE TAPPING: Inlet and outlet pressure taps accessible from top of control. Taps are 1/8 inch NPT with plug containing recess for 3/16 inch Allen wrench.

PRESSURE RATING: A.G.A. rating 1/2 psi [3.5 kPa] inlet pressure.

PRESSURE REGULATION: See Table 1. Regulator adjustment accessible from top of gas control.

MOUNTING: Can be mounted 0 to 90 degrees in any direction from the upright position of the gas control knob. Including vertically.

TEMPERATURE RATING:

VR8300A,C,H: 0° F to +175° F [-18° C to +79° C].

VR8300M,P: -40° F to +175° F [-40° C to +79° C].

DIMENSIONS: See Fig. 1.

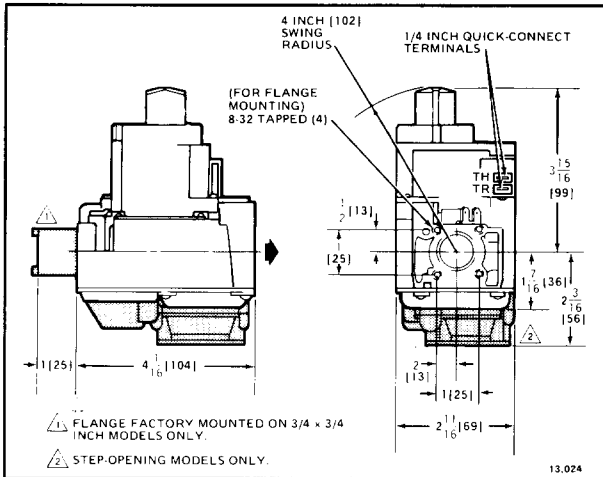

FIG. 1—VR8300 DIMENSIONS IN INCHES AND [MILLIMETERS].

APPROVALS:

AMERICAN GAS ASSOCIATION DESIGN CERTIFICATE: UP-70-69A.

CANADIAN GAS ASSOCIATION DESIGN CERTIFICATE: UP-70-69A.

AUSTRALIAN GAS ASSOCIATION: NOT AVAILABLE.
DELTA C: NOT AVAILABLE.

OPTIONAL SPECIFICATIONS:

- Convenience terminals.

ACCESSORIES:

- Flanges, see Table 3.
- 394349 9/64 inch hex tool for flange assembly screws.
- 393691 Natural to LP gas conversion kit.
- 394588 LP to Natural gas conversion kit.

INSTALLATION

WHEN INSTALLING THIS PRODUCT...

1. Read these instructions carefully. Failure to follow them could damage the product or cause a hazardous condition.
2. Check the ratings given in the instructions and on the product to ensure the product is suitable for your application.
3. Ensure installer is a trained, experienced service technician.
4. After installation is complete, use these instructions to check out product operation.

WARNING

FIRE OR EXPLOSION HAZARD CAN CAUSE PROPERTY DAMAGE, SEVERE INJURY, OR DEATH

Follow these warnings exactly.

1. Disconnect power supply before wiring to prevent electrical shock or equipment damage.
2. To avoid dangerous accumulation of fuel gas, turn off gas supply at the appliance service valve before starting installation, and perform Gas Leak Test after completion of installation.
3. Do not bend pilot tubing at gas control or pilot burner after compression fitting has been tightened, or gas leakage at the connection may result.
4. Always install sediment trap in gas supply line to prevent contamination of gas control.
5. Do not force the gas control knob. Use only your hand to push down the reset button or turn the gas control knob. Never use any tools. If the gas control knob or reset button will not operate by hand, the gas control should be replaced by a qualified service technician. Force or attempted repair may result in fire or explosion.

CAUTION

Never apply a jumper across or short the valve coil terminals. This may burn out the heat anticipator in the thermostat.

IMPORTANT

These gas controls are shipped with protective seals over inlet and outlet tappings. Do not remove seals until ready to connect piping.

Follow the appliance manufacturer's instructions if available; otherwise, use the instructions provided below.

CONVERTING BETWEEN NATURAL AND LP GAS

WARNING

FIRE OR EXPLOSION HAZARD CAN CAUSE PROPERTY DAMAGE, SEVERE INJURY, OR DEATH
Do not use a gas control set for natural gas on LP gas or a gas control set for LP gas on natural gas.

To convert a gas control from natural gas to LP gas or from LP gas to natural gas, contact your Honeywell representative.

Standard- or slow-opening gas controls are converted from one gas to another with a conversion kit (order separately). Order Part Number 393691 to convert from natural to LP gas. Order Part Number 394588 to convert from LP to natural gas. Step-opening gas controls can not be converted.

INSTALL ADAPTERS TO CONTROL

If adapters are to be installed on the gas control, mount them as follows:

Flanges

1. Choose the appropriate flange for your application.
2. Remove seal over gas control inlet or outlet.
3. Ensure the O-ring is fitted in the groove of flange. If the O-ring is not attached or is missing, do not use flange.
4. With O-ring facing gas control, align the screw holes on the gas control with the holes in the flange. Insert and tighten the screws provided with the flange. See Fig. 2. Tighten the screws to 25 inch pounds of torque to provide a gas-tight seal.

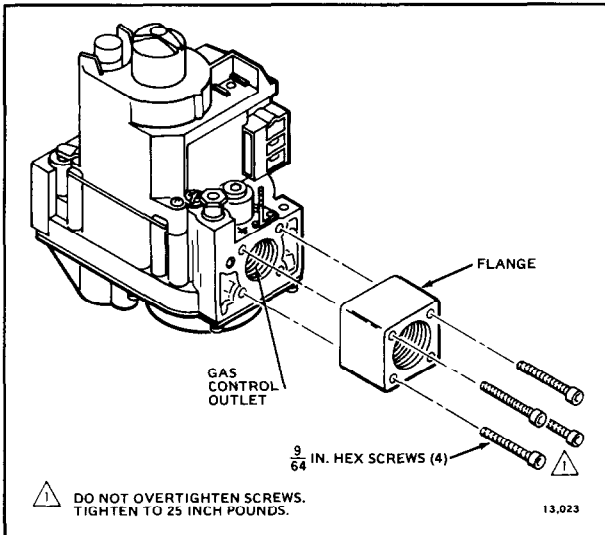

FIG. 2—INSTALL FLANGE TO GAS CONTROL.

Bushings:

1. Remove seal over gas control inlet or outlet.
2. Apply moderate amount of good quality pipe compound to bushing, leaving two end threads bare. On LP installation, use compound resistant to LP gas. Do NOT use Teflon tape.
3. Insert bushing in gas control and thread pipe carefully into bushing until tight.

Complete instructions below for piping, installing control, connecting pilot tubing, thermocouple and wiring. Make certain the leak test you perform on the control after completing the installation includes leak testing the adapters and screws. If you use a wrench on the valve after flanges are installed, use the wrench only on the flange, not the control.

USING ADAPTERS TO SOLVE SWING RADIUS PROBLEMS

In some field service applications, it is difficult or impossible to thread the gas control onto the gas supply pipe because of space limitations. This problem can be resolved in many instances by using an adapter. The adapter is installed on the end of the supply pipe in place of the gas control, following the same precautions and instructions that are used for installing the gas control. After the adapter is installed, the gas control is attached to the adapter as outlined above. Note that using an adapter increases the overall length of the gas control.

CHOOSE GAS CONTROL LOCATION

Do not locate the gas control where it may be affected by steam cleaning, high humidity, dripping water, corrosive chemicals, dust or grease accumulation, or excessive heat. To ensure proper operation, follow these guidelines.

- Locate gas control in a well ventilated area.

- Mount gas control high enough above the cabinet bottom to avoid exposure to flooding or splashing water.
- Ensure the ambient temperature does not exceed the ambient temperature ratings for each component.
- Cover gas control if appliance is cleaned with water, steam, or chemicals or to avoid dust and grease accumulation.
- Avoid locating gas control where exposure to corrosive chemical fumes or dripping water are likely.

Locate the gas control in the appliance vestibule on the gas manifold. In replacement applications, locate the gas control in the same location as the old gas control.

Install Piping to Gas Control

All piping must comply with local codes and ordinances or with the National Fuel Gas Code (ANSI Z223.1 NFPA No. 54), whichever applies. Tubing installation must comply with approved standards and practices.

1. Use new, properly reamed pipe free from chips. If tubing is used, ensure the ends are square, deburred and clean. All tubing bends must be smooth and without deformation.

2. Run pipe or tubing to the gas control. If tubing is used, obtain a tube-to-pipe coupling to connect the tubing to the gas control.

3. Install sediment trap in the supply line to the gas control. See Fig. 3.

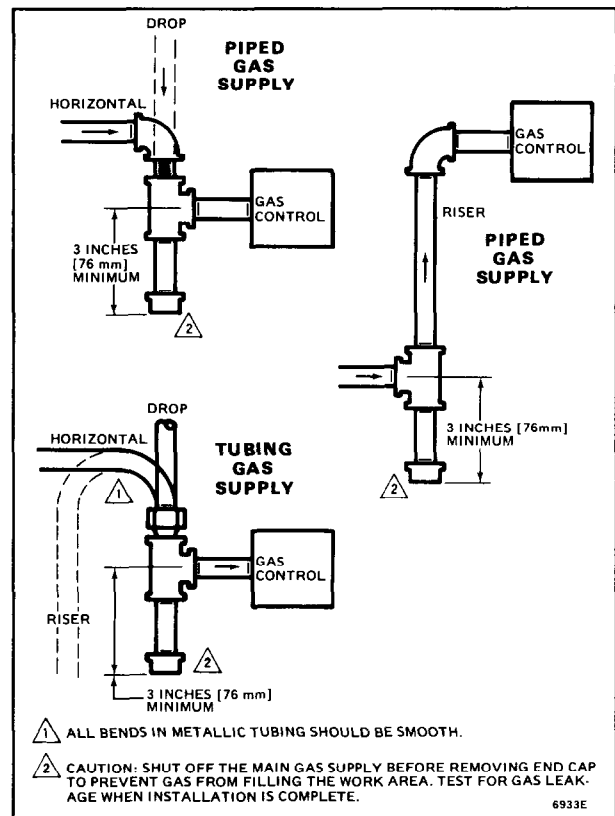

FIG. 3—SEDIMENT TRAP INSTALLATION.

Install Gas Control

1. Mount the gas control 0-90 degrees, in any direction, from the upright position of the gas control knob, including vertically.

2. Mount the gas control so gas flow is in the direction of the arrow on the bottom of the gas control.

3. Thread pipe the amount shown in Table 4 for insertion into gas control. **DO NOT THREAD PIPE TOO FAR.** Valve distortion or malfunction may result if the pipe is inserted too deeply into the gas control.

TABLE 4—NPT PIPE THREAD LENGTH IN INCHES.

PIPE SIZE	THREAD PIPE THIS AMOUNT	MAXIMUM DEPTH PIPE CAN BE INSERTED INTO CONTROL
3/8	9/16	3/8
1/2	3/4	1/2
3/4	13/16	3/4

4. Apply a moderate amount of good quality pipe compound (DO NOT use Teflon tape) to pipe only, leaving two end threads bare. On LP installations, use compound resistant to LP gas.

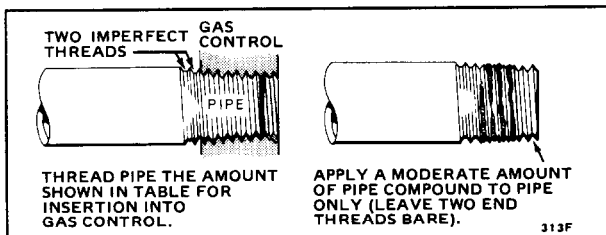

FIG. 4—USE MODERATE AMOUNT OF PIPE COMPOUND.

5. Remove seals over gas control inlet and outlet if necessary.

6. Connect pipe to gas control inlet and outlet. Use wrench on the square ends of the gas control. If an adapter is used, place wrench on adapter rather than gas control. Refer to Figs. 5 and 6.

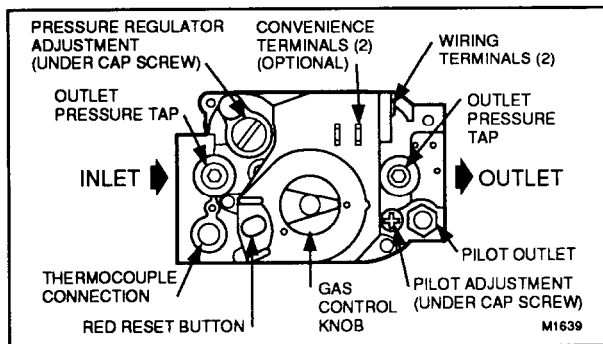

FIG. 5—TOP VIEW OF STANDARD GAS CONTROL.

Connect Pilot Gas Tubing

1. Cut tubing to desired length and bend as necessary for routing to pilot burner. Do not make sharp bends or deform the tubing. Do not bend tubing at gas control or pilot burner after compression fitting has been tightened, as this may result in gas leakage at the connection.

2. Square off and remove burrs from end of tubing.

3. Unscrew compression fitting from the pilot outlet (Fig. 5). Slip the compression fitting over the tubing and slide out of the way.

NOTE: When replacing a gas control, cut off old compression fitting and replace with the new compression fitting provided on the gas control. Never use the old compression fitting as it may not provide a gas-tight seal.

4. Push tubing into the pilot gas tapping on the outlet end of the control until it bottoms. While holding tubing all the way in, slide compression fitting into place and engage threads—turn until finger tight. Then tighten one more turn with wrench. Do not overtighten. Refer to Fig. 7.

5. Connect other end of tubing to pilot burner according to pilot burner manufacturer's instructions.

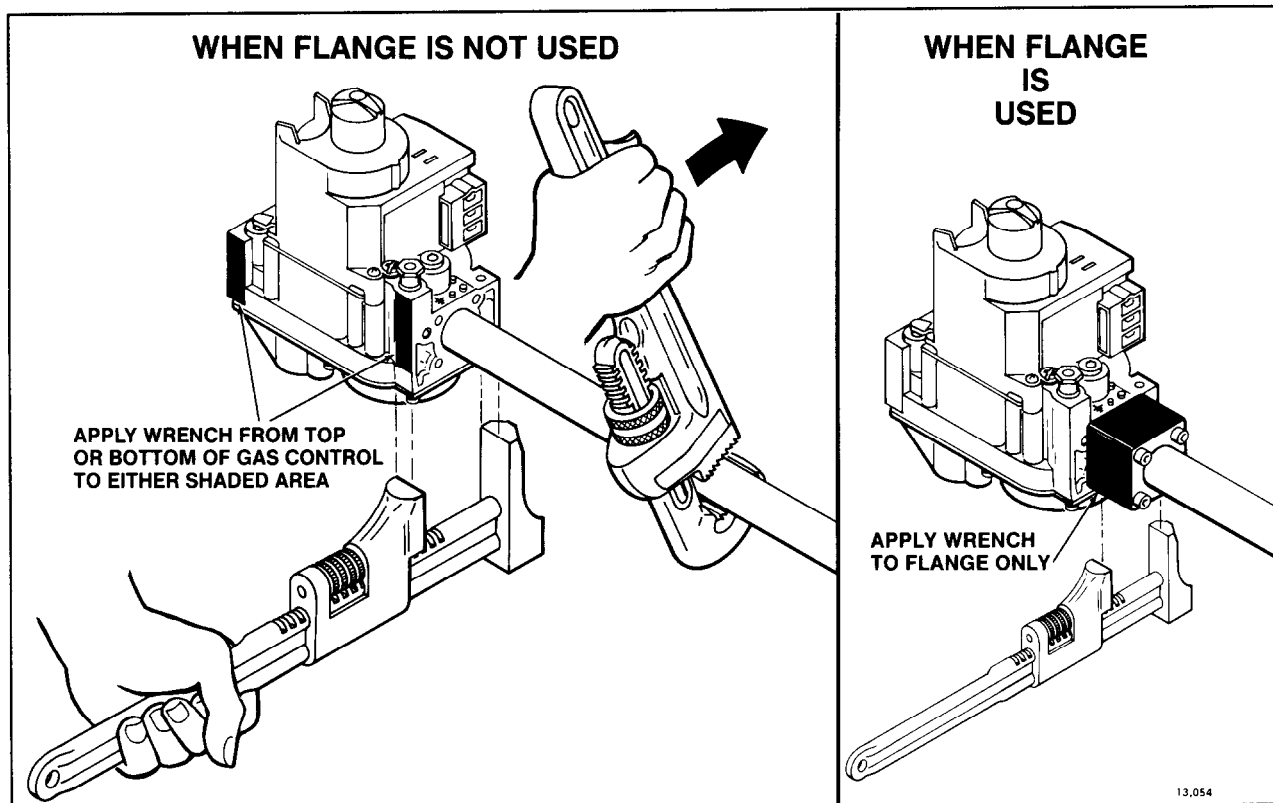

FIG. 6—PROPER USE OF WRENCH ON GAS CONTROL.

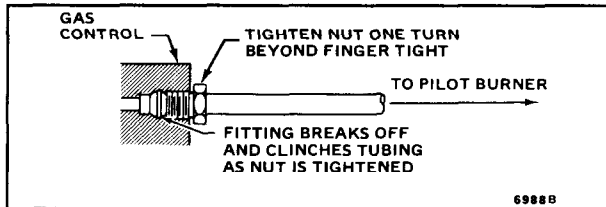

FIG. 7—ALWAYS USE NEW COMPRESSION FITTING.

Connect Thermocouple

Connect thermocouple lead as shown in Fig. 8. This is an electrical connection and must be clean and dry. Never use pipe compound. Tighten only 1/4 turn beyond finger tight to give good electrical continuity. DO NOT OVERTIGHTEN.

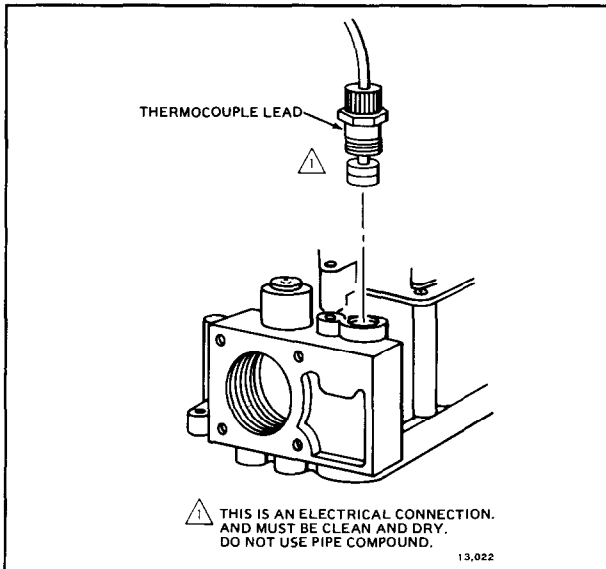

FIG. 8—INSTALLING THERMOCOUPLE TO THE POWER UNIT.

WIRING

Follow the wiring instructions furnished by the appliance manufacturer, if available, or use the general instructions provided below.

All wiring must comply with applicable electrical codes and ordinances.

Disconnect power supply before making wiring connections to prevent electrical shock or equipment damage.

1. Check the power supply rating on the gas control and ensure it matches the available supply. Install transformer, thermostat, and other controls as required.

2. Connect control circuit to gas control terminals. See Figs. 5 and 9.

3. Adjust thermostat heat anticipator to 0.70 rating stamped on valve operator.

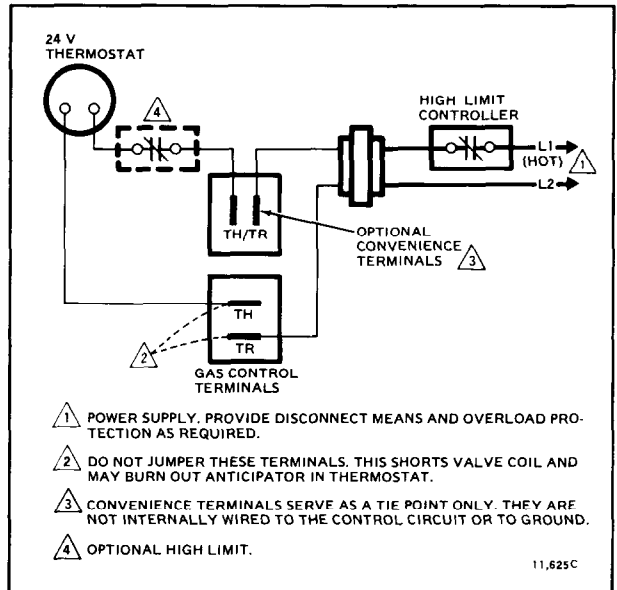

FIG. 9—WIRING CONNECTIONS FOR 24 VOLT CONTROL.

TABLE 5—MAXIMUM LENGTH OF SUPPLEMENTARY LIMIT LEADWIRES WHEN USING Q340A THERMOCOUPLE.

THERMOCOUPLE LENGTH		MAXIMUM LEADWIRE LENGTH X 2 (wires)					
		AWG NO. 14		AWG NO. 16		AWG NO. 18	
inches	meters	inches	meters	inches	meters	inches	meters
18	0.5	35	0.9	22	0.6	13	0.3
24	0.6	29	0.7	18	0.5	11	0.3
30	0.8	23	0.6	15	0.4	9	0.2
36	0.9	17	0.4	11	0.3	6	0.2
48	1.2	DO NOT USE.					
60	1.5						

TABLE 6—MAXIMUM LENGTH OF SUPPLEMENTARY LIMIT LEADWIRES WHEN USING Q309A THERMOCOUPLE.

THERMOCOUPLE LENGTH		MAXIMUM LEADWIRE LENGTH X 2 (wires)					
		AWG NO. 14		AWG NO. 16		AWG NO. 18	
inches	meters	inches	meters	inches	meters	inches	meters
12	0.3	47	1.2	30	0.8	18	0.5
18	0.5	41	1.0	26	0.7	16	0.4
24	0.6	35	0.9	22	0.6	14	0.4
30	0.8	29	0.8	18	0.5	11	0.3
36	0.9	23	0.6	15	0.4	9	0.2
40	1.0	19	0.5	12	0.3	7	0.2
48	1.2	11	0.3	7	0.2	DO NOT USE.	
60	1.5						

START-UP AND CHECKOUT

WARNING

**FIRE OR EXPLOSION HAZARD
CAN CAUSE PROPERTY DAMAGE, SEVERE INJURY, OR DEATH**

1. Do not force the gas control knob. Use only your hand to push down the reset button or turn the gas control knob. Never use any tools.
2. If the gas control knob or reset button will not operate by hand, or if the reset button stays depressed after it is released, the gas control should be replaced by a qualified service technician.

GAS CONTROL KNOB SETTINGS

The gas control knob has three settings:

OFF—prevents pilot and main burner gas flow.

PILOT—permits pilot gas flow only. Gas control knob must be held depressed or thermocouple must be heated sufficiently to hold the safety control valve open.

ON—permits main burner and pilot gas flow. Thermostat and gas control control main burner gas flow.

NOTE: Gas controls are shipped with the gas control knob in the ON position.

PERFORM GAS LEAK TEST

WARNING

**FIRE OR EXPLOSION HAZARD
CAN CAUSE PROPERTY DAMAGE, SEVERE INJURY, OR DEATH**

Check for gas leaks with rich soap and water solution any time work is done on a gas control.

GAS LEAK TEST

1. Paint all pipe connections upstream of the gas control with a rich soap and water solution. Bubbles indicate a gas leak.
2. If a gas leak is detected, tighten the pipe connection.
3. Stand clear while lighting main burner to prevent injury caused from hidden gas leaks which could cause flashback in the appliance vestibule. Light the main burner.
4. With the main burner in operation, paint all pipe joints (including adapters) and gas control inlet and outlet with rich soap and water solution.
5. If another gas leak is detected, tighten adapter screws, joints, and pipe connections.
6. Replace the part if gas leak can not be stopped.

LIGHT THE PILOT BURNER FLAME

1. Turn the gas control knob clockwise to OFF. Wait five minutes to dissipate any unburned gas. Sniff around the appliance near the floor. Do not relight the pilot flame if you smell gas.

2. Turn the gas control knob counterclockwise to PILOT. Push down and hold the gas control knob while lighting the pilot flame.

3. Hold the gas control knob down about one minute, then release.

- If the pilot flame goes out, turn the gas control knob clockwise to OFF and repeat steps one through three.

- If pilot flame remains lit, turn the gas control knob counterclockwise to ON.

ADJUST THE PILOT BURNER FLAME

The pilot flame should envelop 3/8 to 1/2 inch [10 to 13 millimeters] of the thermocouple tip. Refer to Fig. 10. To adjust the pilot flame:

1. Remove the pilot adjustment cover screw. Refer to Fig. 5.
2. Turn the inner adjustment screw clockwise to decrease or counterclockwise to increase the pilot flame.
3. Always replace the cover screw after adjustment and tighten firmly to ensure proper operation.

LIGHT MAIN BURNER

Follow the appliance manufacturer's instructions or set the thermostat setting above room temperature to call for heat.

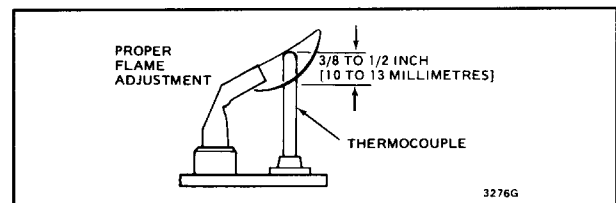

FIG. 10—PROPER FLAME ADJUSTMENT.

CHECK AND ADJUST GAS INPUT TO MAIN BURNER

CAUTION

1. Do not exceed the input rating stamped on the appliance nameplate, or manufacturer's recommended burner orifice pressure for the size orifice(s) used. Ensure the main burner primary air supply is properly adjusted for complete combustion (refer to the appliance manufacturer's instructions).
2. IF CHECKING GAS INPUT BY CLOCKING THE GAS METER:
 - Ensure that the only gas flow through the meter is that of the appliance being tested.
 - Ensure that other appliances are turned off and that their pilot burners are extinguished (or deduct their gas consumptions from the meter reading).
 - Convert the flow rate to Btuh as described in the Gas Controls Handbook (form number 70-2602) and compare to the Btuh input rating on the appliance nameplate.
3. IF CHECKING GAS INPUT WITH A MANOMETER (PRESSURE GAUGE):
 - Ensure the gas control knob is in the PILOT position before removing the outlet pressure tap plug to connect the manometer.
 - Turn the gas control knob back to PILOT when removing the manometer and replacing outlet pressure tap plug.
 - Shut off the gas supply at the appliance service valve or, for LP gas, at the gas tank before removing outlet the pressure tap plug and before disconnecting the manometer and replacing the outlet pressure tap plug.
 - Perform the Gas Leak Test at the inlet pressure tap plug.

Standard-Opening and Slow-Opening Pressure Regulator

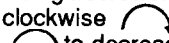
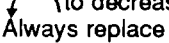
1. The gas control outlet pressure should match the manifold pressure listed on the appliance nameplate.
2. With the main burner operating, check the gas control flow rate using the meter clocking method or check the gas pressure using a manometer connected to the gas control outlet pressure tap. Refer to Fig. 5.
3. If necessary, adjust the pressure regulator to match the appliance rating. Refer to Table 7 or 8 for the factory set nominal outlet pressures and adjustment ranges.
 - a. Remove the pressure regulator adjustment cap and screw.
 - b. Using a screwdriver, turn the inner adjustment screw clockwise  to increase or counterclockwise  to decrease the main burner gas pressure.
 - c. Always replace the cap screw and tighten firmly to ensure proper operation.
4. If the desired outlet gas pressure or gas flow rate cannot be achieved by adjusting the gas control, check the gas control inlet pressure using a manometer at the inlet pressure tap. If the inlet pressure is in the normal range (refer to Table 7 or 8), replace the gas control. Otherwise, take the necessary steps to provide proper gas pressure to the gas control.

Step-Opening Pressure Regulator

1. The gas control outlet pressure should match the manifold pressure listed on the appliance nameplate.

2. With main burner operating, check the gas control flow rate using the meter clocking method or check the gas pressure using a manometer connected to the gas control outlet pressure tap. Refer to Fig. 5.

3. If necessary, adjust the pressure regulator to match the appliance rating. Refer to Table 7 or 8 for factory set nominal outlet pressures and adjustment ranges.

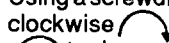
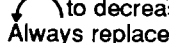
- a. Remove the pressure regulator adjustment cap screw.
- b. Using a screwdriver, turn the inner adjustment screw clockwise  to increase or counterclockwise  to decrease the main burner gas pressure.
- c. Always replace the cap screw and tighten firmly to ensure proper operation.

4. If desired outlet pressure or flow rate cannot be achieved by adjusting the gas control, check the inlet pressure using a manometer at inlet pressure tap or upstream of the gas control. If the inlet pressure is in the normal range (refer to Table 7 or 8), replace the existing gas control. Otherwise, take the necessary steps to provide proper gas pressure to the gas control.

5. Carefully check main burner lightoff at the step pressure. Ensure the main burner lights smoothly and without flashback to the orifice and that all ports remain lit. Cycle the main burner several times, allowing at least 30 seconds between cycles for the regulator to resume the step function. Repeat after allowing main burner to cool. Readjust the full rate outlet pressure if necessary to improve lightoff characteristics.

TABLE 7—PRESSURE REGULATOR SPECIFICATION PRESSURES IN INCHES WC.

MODEL	TYPE OF GAS	NOMINAL INLET PRESSURE RANGE	OUTLET PRESSURE			
			NOMINAL FACTORY SETTING		SETTING RANGE	
			STEP	FULL RATE	STEP	FULL RATE
Standard, Slow-opening	NATURAL LP	5.0 - 7.0 12.0 - 14.0	—	3.5	—	3.0 - 5.0
			—	11.0	—	8.0 - 12.0
Step-opening	NATURAL LP	5.0 - 7.0 12.0 - 14.0	0.9	3.5	—	3.0 - 5.0
			2.2	11.0	—	8.0 - 12.0

TABLE 8—PRESSURE REGULATOR SPECIFICATION PRESSURES IN kPa.

MODEL	TYPE OF GAS	NOMINAL INLET PRESSURE RANGE	OUTLET PRESSURE			
			NOMINAL FACTORY SETTING		SETTING RANGE	
			STEP	FULL RATE	STEP	FULL RATE
Standard, Slow-opening	NATURAL LP	1.2 - 1.7 2.9 - 3.9	—	0.9	—	0.7 - 1.2
			—	2.7	—	2.0 - 3.0
Step-opening	NATURAL LP	1.2 - 1.7 2.9 - 3.9	0.2	0.9	—	0.7 - 1.2
			0.9	2.7	—	2.0 - 3.0

CHECK SAFETY SHUTDOWN PERFORMANCE

WARNING

FIRE OR EXPLOSION HAZARD CAN CAUSE PROPERTY DAMAGE, SEVERE INJURY, OR DEATH
Perform the safety shutdown test any time work is done on a gas system.

1. Place gas control knob in PILOT position. Main burner should go off and pilot should remain lit.

2. Extinguish pilot flame. Pilot gas flow should stop within 2-1/2 minutes. Safety shutoff or pilot gas proves complete shutdown since safety shutoff valve permits main burner and pilot gas flow.

3. Relight pilot burner and operate system through one complete cycle to ensure all controls operate properly.