



Installation Instructions

Brushless DC Motor Upgrade for UniTrane™ Fan-Coil and Force-Flo™ Air Conditioners



This document applies to service offering applications only.

⚠ SAFETY WARNING

Only qualified personnel should install and service the equipment. The installation, starting up, and servicing of heating, ventilating, and air-conditioning equipment can be hazardous and requires specific knowledge and training. Improperly installed, adjusted or altered equipment by an unqualified person could result in death or serious injury. When working on the equipment, observe all precautions in the literature and on the tags, stickers, and labels that are attached to the equipment.



Introduction

Read this manual thoroughly before operating or servicing this unit.

Warnings, Cautions, and Notices

Safety advisories appear throughout this manual as required. Your personal safety and the proper operation of this machine depend upon the strict observance of these precautions.

The three types of advisories are defined as follows:

- WARNING** Indicates a potentially hazardous situation which, if not avoided, could result in death or serious injury.
- CAUTION** Indicates a potentially hazardous situation which, if not avoided, could result in minor or moderate injury. It could also be used to alert against unsafe practices.
- NOTICE** Indicates a situation that could result in equipment or property-damage only accidents.

Important Environmental Concerns

Scientific research has shown that certain man-made chemicals can affect the earth's naturally occurring stratospheric ozone layer when released to the atmosphere. In particular, several of the identified chemicals that may affect the ozone layer are refrigerants that contain Chlorine, Fluorine and Carbon (CFCs) and those containing Hydrogen, Chlorine, Fluorine and Carbon (HCFCs). Not all refrigerants containing these compounds have the same potential impact to the environment. Trane advocates the responsible handling of all refrigerants.

Important Responsible Refrigerant Practices

Trane believes that responsible refrigerant practices are important to the environment, our customers, and the air conditioning industry. All technicians who handle refrigerants must be certified according to local rules. For the USA, the Federal Clean Air Act (Section 608) sets forth the requirements for handling, reclaiming, recovering and recycling of certain refrigerants and the equipment that is used in these service procedures. In addition, some states or municipalities may have additional requirements that must also be adhered to for responsible management of refrigerants. Know the applicable laws and follow them.

WARNING

Proper Field Wiring and Grounding Required!

Failure to follow code could result in death or serious injury. All field wiring **MUST** be performed by qualified personnel. Improperly installed and grounded field wiring poses **FIRE** and **ELECTROCUTION** hazards. To avoid these hazards, you **MUST** follow requirements for field wiring installation and grounding as described in **NEC** and your local/state/national electrical codes.

WARNING

Personal Protective Equipment (PPE) Required!

Failure to wear proper PPE for the job being undertaken could result in death or serious injury. Technicians, in order to protect themselves from potential electrical, mechanical, and chemical hazards, **MUST** follow precautions in this manual and on the tags, stickers, and labels, as well as the instructions below:

- Before installing/servicing this unit, technicians **MUST** put on all PPE required for the work being undertaken (Examples; cut resistant gloves/sleeves, butyl gloves, safety glasses, hard hat/bump cap, fall protection, electrical PPE and arc flash clothing). **ALWAYS** refer to appropriate Safety Data Sheets (SDS) and OSHA guidelines for proper PPE.
- When working with or around hazardous chemicals, **ALWAYS** refer to the appropriate SDS and OSHA/GHS (Global Harmonized System of Classification and Labeling of Chemicals) guidelines for information on allowable personal exposure levels, proper respiratory protection and handling instructions.
- If there is a risk of energized electrical contact, arc, or flash, technicians **MUST** put on all PPE in accordance with OSHA, NFPA 70E, or other country-specific requirements for arc flash protection, **PRIOR** to servicing the unit. **NEVER PERFORM ANY SWITCHING, DISCONNECTING, OR VOLTAGE TESTING WITHOUT PROPER ELECTRICAL PPE AND ARC FLASH CLOTHING. ENSURE ELECTRICAL METERS AND EQUIPMENT ARE PROPERLY RATED FOR INTENDED VOLTAGE.**

⚠ WARNING**Follow EHS Policies!**

Failure to follow instructions below could result in death or serious injury.

- All Trane personnel must follow the company's Environmental, Health and Safety (EHS) policies when performing work such as hot work, electrical, fall protection, lockout/tagout, refrigerant handling, etc. Where local regulations are more stringent than these policies, those regulations supersede these policies.
- Non-Trane personnel should always follow local regulations.

Copyright

This document and the information in it are the property of Trane, and may not be used or reproduced in whole or in part without written permission. Trane reserves the right to revise this publication at any time, and to make changes to its content without obligation to notify any person of such revision or change.

Trademarks

All trademarks referenced in this document are the trademarks of their respective owners.

Revision History

Document updated to reflect Service Offering number.



Table of Contents

General Information	5
About this Manual	5
Service Information	5
Overview	6
Kit Information	6
Kit Contents	6
Kit Selection	7
Installation	8
Tools Required	8
Field-Provided Materials	8
Removal of Existing Motor	8
Controls Installation	8
Motor Rotational Direction	10
Motor Installation	11
Entering Values for Motor Speed	12
Start-up Procedure	13
Component Descriptions	14
BLDC Motor	14
ECM Engine Model	14
Universal Adapter Board	14
Wire Harness	15
Control Board Mounting Bracket	15
Controls Configuration	16
General Description	16
Parameter List	18
Configuration Settings of the ECM Engine Board	19
Troubleshooting	21
Priority and Error Codes	21
Motor Operation	22
Other Unit Functions	23



General Information

About this Manual

This manual is intended for use by experienced service personnel, qualified electrical personnel, and Trane service personnel who are familiar with the features described. The instructions in this manual outline the procedures for installing the Trane brushless DC motor upgrade for UniTrane fan-coil and Force-Flo air conditioners. Operation of the controls is also explained in this manual.

Service Information

This equipment should be installed, adjusted and serviced by qualified electrical maintenance personnel who are familiar with the construction and operation of the equipment and the hazards involved, as defined in the National Electrical Code. Trane assumes no liability for installation or service procedures performed by unqualified personnel.



Overview

Kit Information

These instructions describe how to upgrade existing UniTrane fan-coil and Force-Flo air conditioner units by integrating new Trane brushless DC motors and controllers. The necessary parts have been conveniently packaged in upgrade kits to aid in installation. This exciting new technology delivers outstanding comfort, safety, and performance with greatly reduced energy consumption compared to permanent split capacitance AC motors. These upgrades will provide a long service life with proper installation and operation. The new system provides a high degree of flexibility and configurability.

This kit has been designed as a direct replacement for a multiple-speed PSC motor. The included controls will convert

the existing speed signals into commands compatible with the BLDC motor. No building automation system (BAS) programming or configuration should be required as a result of this upgrade.

Very little intervention is needed by service and installation personnel in most applications; however, installers must read through the entire manual before beginning installation of the new kit.

Kit Contents

The following table describes the contents of each kit. Verify that all parts are included before beginning the installation. For full descriptions and details of each component, refer to [“Component Descriptions,” p. 14.](#)

Table 1. Trane BLDC motor upgrade kit

	KIT19853	KIT19854	KIT19855	KIT19856	KIT19857	KIT16277	KIT16278
BLDC Motor	MOT14521	MOT14522	MOT14523	MOT14524	MOT14525	MOT14521	MOT14523
ECM Engine Module	MOD02616	MOD02616	MOD02616	MOD02616	MOD02616		
Universal Adapter Board	BRD04290	BRD04290	BRD04290	BRD04290	BRD04290		
Wire Harness	WIR06654	WIR06654	WIR06654	WIR06654	WIR06654	WIR06655	WIR06655
Control Board Mounting Bracket	BRK04181	BRK04181	BRK04181	BRK04181	BRK04181		



Kit Selection

Table 2 indicates which kits to order for specific units.

Table 2. Kit selection

Unit Voltage and Type			
Unit cfm	115/208–230 Standard	277 Standard	115/208–230 Low Boy ^(a)
200	KIT19853	KIT19855	KIT19857
300	KIT19853	KIT19855	KIT19857
400	KIT19853	KIT19855	KIT19857
600	KIT19854	KIT19856	Not Applicable
800	KIT19854	KIT19856	Not Applicable
1000	KIT19854 and KIT16277	KIT19856 and KIT16278	Not Applicable
1200	KIT19854 and KIT16277	KIT19856 and KIT16278	Not Applicable

(a) Motors in Low Boy units may be mounted in the unit control box. The new BLDC motor should mount to the top of the control box. Only one shaft of the new BLDC motor should be used. The top of the control box may need to be modified to mount the new BLDC motor. For example, mounting holes may need to be drilled.



Installation

Tools Required

Common hand tools and hand-held power tools are required to perform the work. A trained service technician with a well-stocked tool chest should have all of the necessary tools to perform the job. The following list is a sampling of the tools that one could expect to find inside the technician's tool chest:

- Electric drill and bit set
- Extension cord
- Screwdrivers
- Wrenches
- Ratchet and socket set
- Nut driver set
- Wire cutter
- Wire stripper
- Digital multi-meter

The following special tools may optionally be used to ease the retrofit installation:

- ECM Configuration Kit

Field-Provided Materials

Some field-provided material may be required to perform the BLDC motor upgrade. Additional wire, wire ties, and electrical tape may be used to route the newly installed wire harness in a neat manner.

In some installations, there may not be adequate room inside unit control box to install the new controls boards that are required. In this case, a field-provided enclosure of at least 6-inch x 6-inch x 6-inch will be required. Wiring from the field supplied enclosure may be routed to the unit control box through a conduit nipple with a trade size of 1 inch or larger.

Removal of Existing Motor

Before completely removing the motor, it is important to make note of several features of the existing equipment:

- Inspect the fan wheel. If this wheel wobbles when it spins or is damaged/bent, it will need to be replaced for proper unit operation and to prevent the fan wheel from rubbing on its housing.

⚠ WARNING

Do Not Reverse Polarity!

Failure to follow instruction could result in death or serious injury, and equipment damage. Reversing the polarity to the BLDC controls could result in a direct line to ground fault, thus exposing technicians to hazardous live voltage.

- Inspect the incoming power connection. It is possible for some units with PSC motors to run when voltage polarity is reversed. However, the BLDC motor controls will not work if polarity is reversed.

- Record the rotational direction of the motor. The BLDC replacement motor may need to be configured to match the existing unit. Refer to "[Motor Rotational Direction](#)," p. 10.
- Locate and record the RPM values for the High, Medium, and Low speeds. These values will need to be programmed into the ECM Engine Module.

Motors are attached to the fan boards with screws at the rear of the motors. Fan wheels are attached with Allen screws on the fan hubs. In most applications, it is necessary to remove the fan board to change out the motor. The fan board is easily removable, with screws on the front left and right edges of fan boards for vertical units, or on the front left underside and front right underside of the fan board for horizontal units. These screws may be concealed by a gasket.

⚠ WARNING

Hazardous Voltage w/Capacitors!

Failure to disconnect power and discharge capacitors before servicing could result in death or serious injury. Disconnect all electric power, including remote disconnects and discharge all motor start/run capacitors before servicing. Follow proper lockout/tagout procedures to ensure the power cannot be inadvertently energized. For variable frequency drives or other energy storing components provided by Trane or others, refer to the appropriate manufacturer's literature for allowable waiting periods for discharge of capacitors. Verify with a CAT III or IV voltmeter rated per NFPA 70E that all capacitors have discharged.

1. Disconnect power to the unit and ensure it cannot be turned on during installation.
2. Remove front panels of unit.
3. Remove drain pan and drain pan support on vertical units or remove drain pan on horizontal units.
4. Remove the control box cover.
5. Disconnect and remove the existing motor wiring from the unit control box. Also remove any conduit and fittings associated with this wiring.
6. Remove the fan board attachment screws and carefully lower/slide-out fan board.
7. Remove at least one fan housing, and loosen fan Allen screw on first fan. If a double shafted motor, loosen the wheel of the other fan.
8. Unscrew the motor and remove.
9. Some units may have a 1/2-inch spacer plate between the motor and the fan board. If present, remove this plate.
10. If two motors are included in the unit, repeat the necessary steps to remove the second motor.

Controls Installation

The ECM Engine Module and Universal Adapter Board are two new control boards that are required for motor operation. The

boards are intended to be mounted using the included Control Board Mounting Bracket.

The eight holes on the face of the Control Board Mounting Bracket are for mounting the ECM Engine Module and Universal Adapter Board. One board will be mounted to each side of the bracket using the plastic standoffs that are part of the control boards. The two holes on the flange of the bracket are for mounting the bracket to control box. Two self-drilling sheet metal screws are provided to secure the bracket. The following images indicate the intended board mounting.

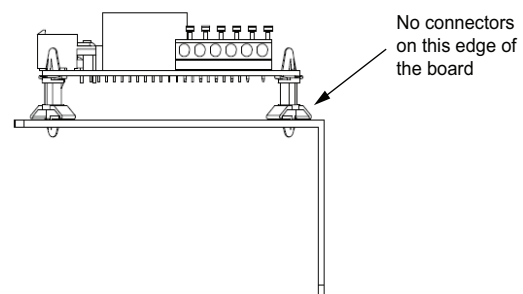
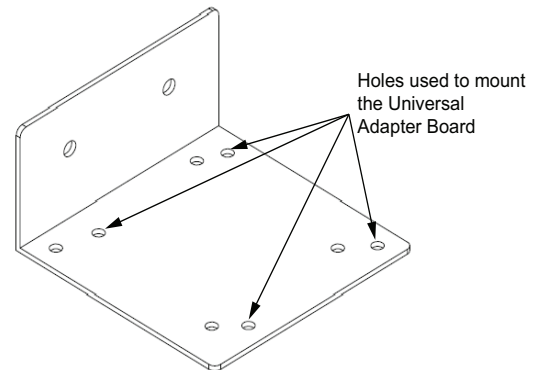
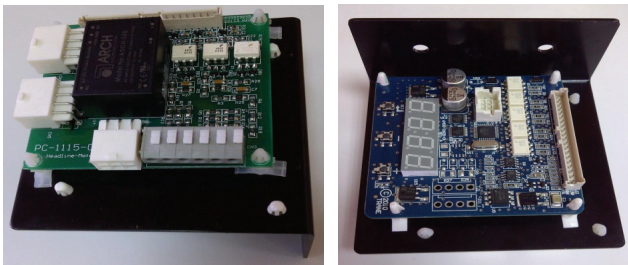

Because control boxes and unit options vary, the installer must locate a space in the box that will accommodate the new controls. The location must meet the following requirements.

- The location must provide adequate space to accommodate the mounting bracket, control boards, and installed wiring. The mounting bracket may not be modified.
- The location must not cause the control boards or mounting bracket to come in contact with any live components.
- The location must not cause the mounting bracket to interfere with any holes used for wiring or device mounting.
- The Universal Adapter Board includes line voltage components and should be installed such that the installer will not come in contact with these components when the unit is powered. Preferably the top of the Universal Adapter Board should face the back of the control box.
- The ECM Engine Module is powered by 24 volts DC and must be accessible for configuration when powered. Preferably, the display and buttons on the ECM Engine Module should face the main control box opening.

Note: If it is not practical to access the ECM engine board after installation, contact Trane Global Parts to purchase a configuration kit that allows easy powering of the engine board outside of the unit with a 9V battery.

1. Locate the ECM Engine Module, Universal Adapter Board, Control Board Mounting Bracket with self-drilling screws, and Wire Harness included in the kit.
2. Mount the Universal Adapter Board to the Control Mounting Bracket as shown in the following figure. The side of the board without any connectors should be on the same side as the mounting flange. Align the four plastic standoffs press down to place. Verify all four standoffs have snapped into place.

3. Connector CN3 on the Universal Adapter Board has been provided to receive motor speed requests.
 - a. For units with an existing motor plug, remove the plug and strip the existing Neutral, Low Speed, Medium Speed, and High Speed wires.
 - b. For units where the motor plugs directly into the controls, locate the 24-inch daughter board adapter that is part of the Wire Harness. This adapter plugs directly into the daughter board and provides pre-stripped Neutral, Low Speed, Medium Speed, and High Speed wires.

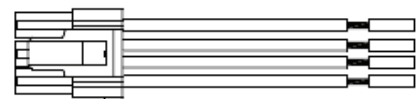
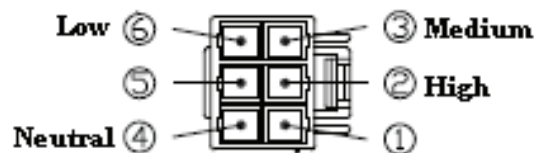

- c. Press down each terminal block gate and insert Neutral, Low Speed, Medium Speed, and High Speed wires directly into the terminal block. The following figure shows the order of connections.

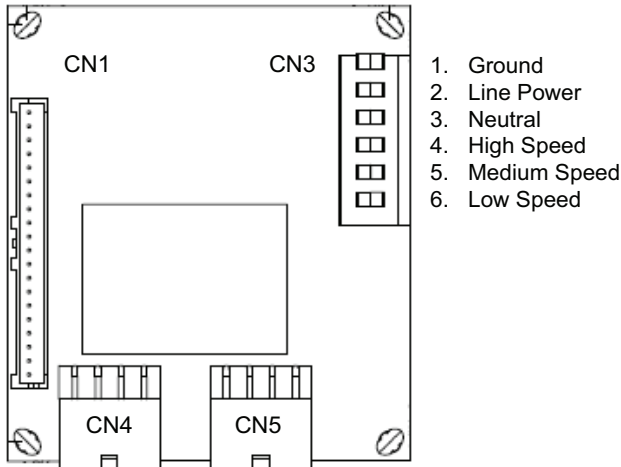

4. The connections made in [Step 3](#) provide the controls with High, Medium, and Low speed signals as well as Neutral. The controls also require a line voltage connection. The wire harness includes a pre-stripped wire and splice connector to make this connection. Locate the wire bringing line power into the unit.

Important: Do NOT cut, strip, or disconnect the wire bringing line power into the unit.

5. Insert this wire into the splice connector.
6. Insert the un-stripped end of the 24-inch wire provided into the third hole of the connector. Verify that the wire is inserted fully into the connector (approximately 1/2 inch).
7. Verify that the wires cannot slip out of the connector.
8. Using pliers, squeeze the metal blade into the connector in order to pierce the insulation of both wires. Verify that the blade and cover on the connector are snapped firmly in place since metal blade will become energized when power is restored.
9. Insert the stripped end of the new power wire into Position 2 of connector CN3.
10. Using field provided wire, connect Position 1 of connector CN3 to a grounded part of the control box.
11. Locate the 20-wire assembly that is part of the wire harness and insert one end into the 20-pin connector (CN1) on the Universal Adapter Board. Verify the connectors are fully mated and the wires are secure.
12. Select a location to mount the control boards. The location must meet all the requirements a beginning of this section.
13. With the Universal Adapter Board facing away from you, use the self-drilling screws to secure the Control Board Mounting Bracket to the control box.

14. Hold the ECM Engine Module up to the mounting bracket so that the 20-pin connectors on both boards are along the same edge. Align the four plastic standoffs with the remaining set of holes in the mounting bracket and press to secure. Verify all four standoffs have snapped into place.

15. Insert the loose end of the 20-wire assembly into the 20-pin connector (J2) on the ECM engine board. Be careful not to twist the wire assembly or rub it against the edge of the mounting bracket. Verify the connectors are fully mated and the wires are secure.

Motor Rotational Direction

All motor are factory configured to run in the counter-clockwise configuration. Counter-clockwise is defined by the following figure. This is the proper direction for most units.

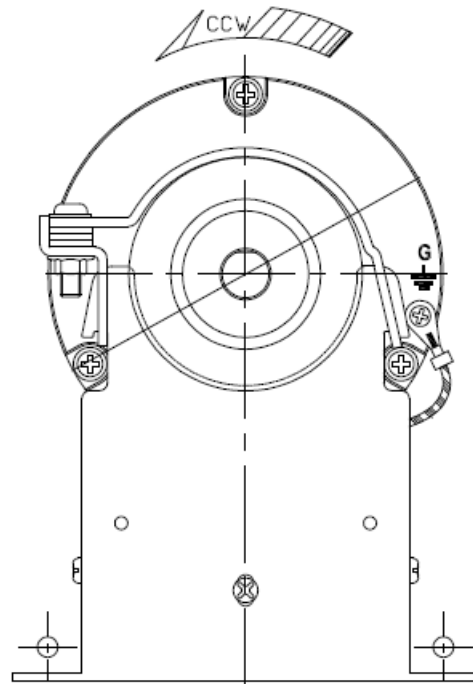

A minority of units require the motor to run in the clockwise direction. For example, units with single-shaft motors that have piping on the left side of the unit will require the motor direction to be reversed.

A jumper on the base of the motor controls direction. To reconfigure a motor to turn in the clockwise direction, this jumper must be removed. To remove this jumper, the motor must not be installed in the unit, and nothing may be plugged into the connector on the side of the motor.

⚠ WARNING

Hazardous Voltage w/Capacitors!

Failure to follow these instructions could result in death or serious injury.

Disconnect all electric power, including remote disconnects and discharge all motor start/run and AFD (Adaptive Frequency™ Drive) capacitors before servicing. Follow proper lockout/tagout procedures to ensure the power cannot be inadvertently energized.

- For variable frequency drives or other energy storing components provided by Trane or others, refer to the appropriate manufacturer's literature for allowable waiting periods for discharge of capacitors. Verify with an appropriate voltmeter that all capacitors have discharged.
- DC bus capacitors retain hazardous voltages after input power has been disconnected. Follow proper lockout/tagout procedures to ensure the power cannot be inadvertently energized. After disconnecting input power, wait five (5) minutes for the DC capacitors to discharge, then check the voltage with a voltmeter. Make sure DC bus capacitors are discharged (0 VDC) before touching any internal components.

A red-colored jumper installed in a two-pin connector should be visible on the base of the motor. When this jumper is installed, the motor rotates counter-clockwise. When the jumper is removed, the motor rotates clockwise.

Note: Once this jumper is removed, do not discard it. It will be required to be reinstalled if the counter-clockwise rotation needs to be restored.

For double-shaft motor, direction may be reversed by simply rotating the motor 180 degrees.

Motor Installation

1. Place the BLDC motor on the fan board and secure using the following included hardware:

Description	Quantity
M5 x 20 hex head screws	4
M5 flat washers	8
M5 hex nuts	4

2. Separate the wire and conduit assembly from the rest of the wire harness.

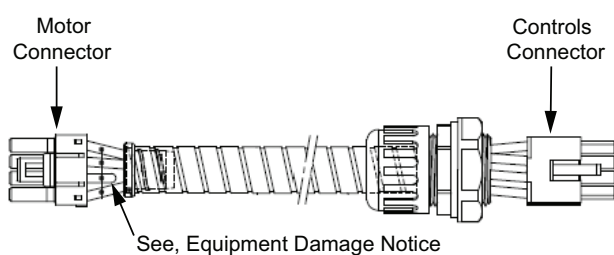

NOTICE

Equipment Damage!

The voltage jumper on the motor plug harness must be removed for 208/230V units and 277V units. If the jumper is present for these units, the motor electronics will be damaged, and the motor will not be controllable.

3. The BLDC motor is configured for voltage by use of an external jumper on pins 2 and 6 the motor connector. If the jumper is present, the motor will be configured for use with 115V. The jumper must NOT be present for use with 208/230V.
 - a. For 115V units, verify the jumper between pins 2 and 6 is present and proceed to [Step 4](#).
 - b. For 208/230V and 277V units, cut the jumper between pins 2 and 6 and individually wrap the ends of the wires with electrical tape to prevent incidental contact. Proceed to [Step 4](#).
4. Insert the connector on the motor end of the wire assembly into the connector on the motor. Verify the connectors are fully mated.
5. Slide the conduit towards the motor so that the end of the conduit is as close to the motor connector as possible.
6. Locate the motor junction box and screws.
7. Insert the tab on the junction box into the slot on the motor and lower the junction box over the motor connector and the end of the conduit. Secure the junction box with included screws. Verify conduit and junction box are secure.
8. Retighten the fan allen screws on each fan.
9. Verify the fan wheel is centered in the assembly and does not rub when rotated.
10. If the unit requires a second motor, repeat the preceding steps above ([Step 1](#) through [Step 7](#)).
11. Lift the fan board back into place and secure it using the fan board attachment screws.
12. Route the wire in conduit back to the unit control box. The wire harness may be longer than is required. Neatly coil any additional length and secure it using wire ties.
13. The conduit fitting on the end of the assembly mates with a 1-inch hole. Use a drill or punch to increase the size of the hole in the control box if existing hole is less than 1 inch.

Note: On some units, misalignment and gap between the control box and the unit may interfere with the installation on the conduit fitting. In this event, increase the clearance hole in the unit to allow the conduit fitting to pass through.
14. Remove the plastic locknut from the conduit fitting, and insert the wires and fitting into the existing knockout in the control box.

Installation

15. On the inside of the control box, thread the wire through the plastic locknut.
16. Thread the locknut onto the conduit fitting and tighten to secure the conduit in place.
17. If the unit requires a second motor, repeat the preceding steps (Step 10 through Step 13).
18. Insert the connectors into the Universal Adapter Board. The connector associated with Motor 1 should mate with CN4 (adjacent to the 20-pin connector [CN1]).
19. The connector associated with Motor 2 should mate with CN5.

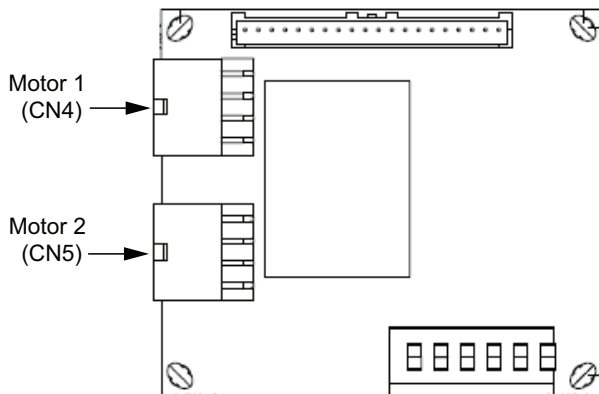

20. When these steps are complete, proceed to “[Entering Values for Motor Speed](#),” p. 12 and “[Start-up Procedure](#),” p. 13.
21. Reinstall the control box cover.
22. Reinstall drain pan and drain pan support on vertical units or remove drain pan on horizontal units.
23. Reinstall front panels of unit.
24. Restore power to the unit.

Entering Values for Motor Speed

Important: All settings take effect immediately, including fan start-up and enabling of electric heat.

⚠ WARNING

Safety Alert!

Failure to follow these instructions could result in death or serious injury.

Stay clear of hazardous voltages, moving parts and electric heat elements while making adjustments to the ECM engine board. If it is not practical to stay clear of these areas during adjustment of the ECM engine board, contact Trane Global Parts for configuration kit that allows easy powering of the engine board outside of the unit with a 9V battery.

The ECM engine board must be configured for proper operation. Specifically, the high, medium, and low speeds for each motor must be programmed into the new ECM Engine Module. Refer to “[Controls Configuration](#),” p. 16, for more detailed descriptions of all parameters and how to configure them.

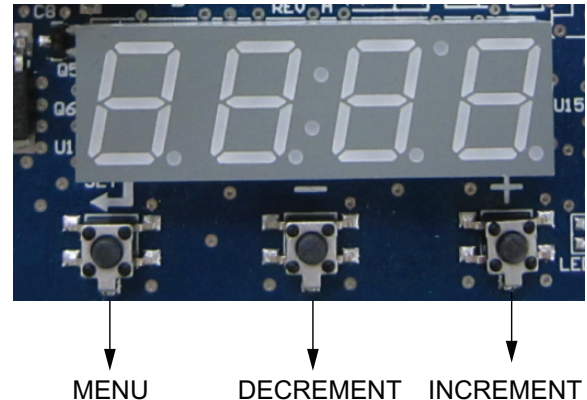

Notes:

- Short press refers to pressing a button and releasing it immediately. Long press refers to pressing and holding it down for more than 3 seconds before releasing it.
 - It may be helpful to set the unit fan speed to **off** using the unit speed switch or BAS to prevent unintentional fan operation during initial programming.
 - Maintain a record of all parameter settings in case of controls modification or failure.
1. Restore power to the unit.
 2. Long press **MENU** to enter the Configuration Menu.
 3. Use **INCREMENT/DECREMENT** to scroll to **K1 4** in order to program the high speed setting for Motor 1.
 4. Short press **MENU** to view parameter setting.
 5. Use **INCREMENT/DECREMENT** to change the setting of the parameter to match the value of the original PSC motor.
 6. Long-press **MENU** to save the setting and return to the parameter name.
 7. Repeat these steps to for the medium speed (**pg 4**) and low speed (**or 4**) for Motor 1.
 8. Repeat steps 1-6 for the high speed (**K1 5**), medium speed (**pg 5**), and low speed (**or 5**) for Motor 2.
 - a. If the unit only requires one motor, these values for Motor 2 must be set to zero.
 - b. If a second motor is installed, enter the values of the original PSC motor.



Start-up Procedure

After configuring the ECM Engine Board with the unit specific parameters, perform the following procedure to verify fan speed response.

1. Observe the display on the ECM Engine board with the power on, to the unit. The ECM engine display should display a looping status indicator as follows:

Pwu4 → 3 → Pwu5 → 3 → IVw4 →
Rii → Ivw5 → Rii → HkHq → Rq

Notes:

- The HkHq indicator is unit-specific and may indicate off at this point.
 - A representative fan speed of 1080 rpm is shown in the following example. Each unit is configured differently and will have different settings for different fan speeds.
2. While the unit remains on, exercise the fan controls on the unit, either directly or indirectly through request for unit heat/cool. Observe the fan spinning, and then observe the fan display on the ECM engine board. It should display a looping status indicator as follows:

For a size 200, 300, 400, 600, or 800 unit (using typical unit operating fan speeds):

Pwu4 → 43;3 → Pwu5 → 3 → IVw4 →
Rq → Ivw5 → Rii → HkHq → Rq

For a size 1000 or 1200 unit (using typical unit operating fan speeds):

Pwu4 → 43;3 → Pwu5 → 43;3 →
IVw4 → Rq → Ivw5 → rq → HkHq →
Rq

Note: The HkHq indicator is unit-specific and may indicate off at this point.

OPTIONAL:

1. While the fan is running, if practical, change the fan speeds and observe the display temporarily indicate: ~~udps~~
2. Exercise all fan speeds to confirm positive unit response and to validate any field wiring.



Component Descriptions

BLDC Motor

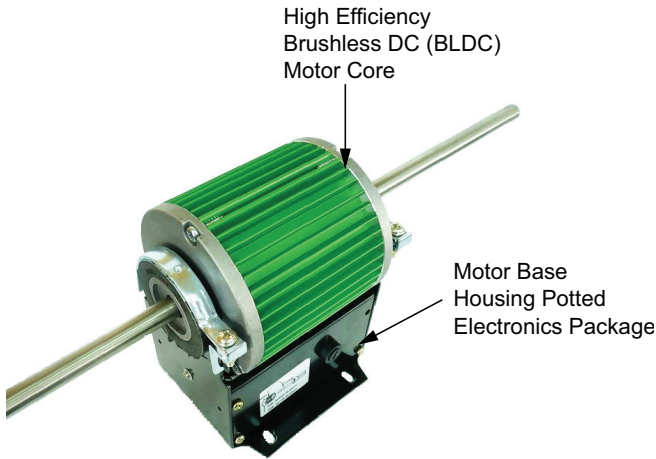

The BLDC motor delivers outstanding comfort, safety, and performance with greatly reduced energy consumption compared to permanent split capacitance AC motors. It has integrated electronics, overload protection and short circuit protection. A single plug is used to connect the motor to the unit controls. The plug contains both the operating voltage and the control signals that are needed for correct operation. The motor harness attached to this plug contains the very important motor voltage jumper and should not be modified or substituted.

NOTICE

Equipment Damage!
 The voltage jumper on the motor plug harness must be removed for 208/230V units and 277V units. If the jumper is present for these units, the motor electronics will be damaged, and the motor will not be controllable.

The BLDC motor has two voltage variations: 115/208–230V and 277V. Units with 3-phase plus neutral have motors wired to the L-N, as opposed to L-L. For instance, a 460V/3/60 unit will employ a 277V motor. The 115/208–230V is configured for voltage by use of an external jumper. If the jumper is present the motor will be configured for use with 115V. The jumper must NOT be present for use with 208–230V.

The BLDC motor comes in both single-shaft (sizes 200, 300, 400, 1000, and 1200) and double-shaft (sizes 600, 800, 1000, and 1200) configurations.

Note: Sizes 1000 and 1200 have both a single-shaft and a double-shaft motor installed.

The BLDC motor includes a junction box and two screws that are shipped loose. Also included is the following list of hardware for mounting the motor.

Description	Quantity
M5 x 20 hex head screws	4
M5 flat washers	8
M5 hex nuts	4

ECM Engine Model

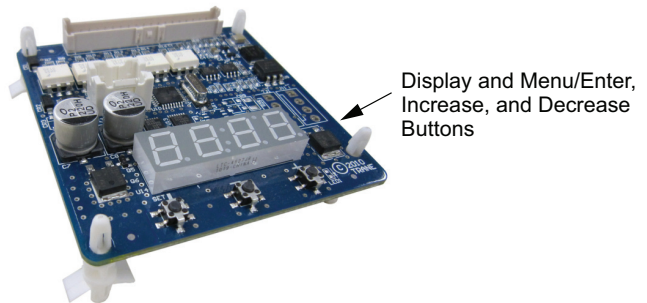

The ECM engine board controls and reports the performance of up to two Trane BLDC motors. It incorporates a user interface that allows adjustment of certain unit parameters and provides constant feedback on motor operation. The engine integrates service and troubleshooting tools including high precision tachometers, fan status and electric heat-enable indicators.

Universal Adapter Board

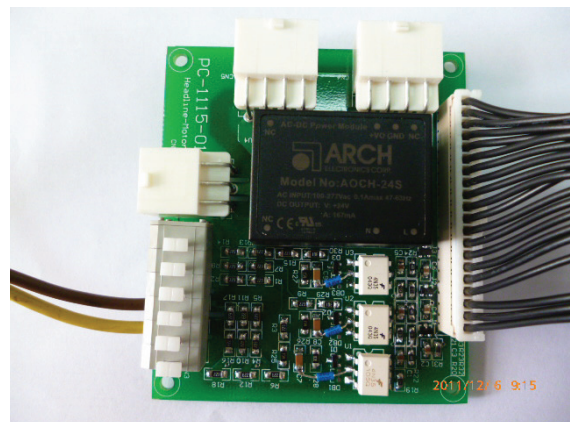

The Universal Adapter Board allows this upgrade kit to be a direct replacement for a PSC motor. This board provides power to the ECM Engine Module, provides a connection point for up to two motors, and converts the line voltage speed signals to signals that are compatible with the BLDC motor.

Wire Harness

The wire harness included in these kits consists of several wire assemblies. Not all included assemblies will be used in installation. The necessary assemblies depend on existing equipment.

Wire harness WIR06654 contains the following assemblies:

- One, 70-inch wire and conduit assembly for connecting the BLDC motor to the Universal Adapter Board.
- One 24-inch, 4-wire assembly for connecting existing daughter boards to the Universal Adapter Board.
- One 6-inch, 20-wire assembly for connecting the ECM Engine Board to the Universal Adapter Board.
- One 24-inch, single wire and splice connector for bringing power to the Universal Adapter Board.

Wire harness WIR06655 contains the following assemblies:

- One, 70-inch wire and conduit assembly for connecting the BLDC motor to the Universal Adapter Board.

Control Board Mounting Bracket

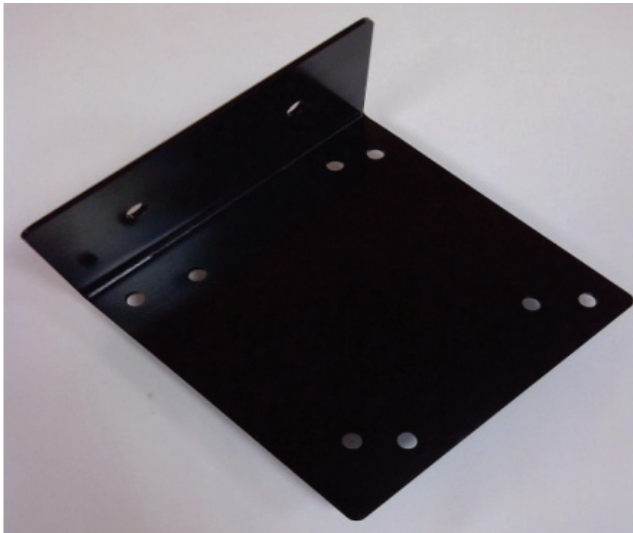

The control board mounting bracket is used to mount the universal adapter board and ECM engine module. Two self-drilling screws are included to mount this bracket to the existing unit control box.

Controls Configuration

General Description

Important: All settings take effect immediately, including fan start-up and enabling of electric heat.

⚠ CAUTION

Burn Hazard!
Failure to follow this instruction could result in the unit overheating and becoming hot to the touch, which could result in minor or moderate injury, and/or equipment damage.

On electric heat units, certain parameter values are locked out to prevent overheating of the unit. These functions will appear to be saved; however, they will not be accepted if the Electric Heat Protection setting is “On”. Do not change the Electric Heat Protection setting to “Off” and make changes to the protected settings unless you are programming an unconfigured service replacement board to match the unit settings on a ECM configuration label.

NOTICE

Motor Damage!
Failure to follow this instruction could result in motor damage. Do not change the PWM output voltage settings.

The ECM engine board features a nested menu integrated user interface (UI) that supports:

1. Status display for instant touch-free confirmation of unit operation.
2. Configuration parameter and value display and modification changes (using integrated set buttons).
3. Error code prioritized reporting.

Figure 1. Status display

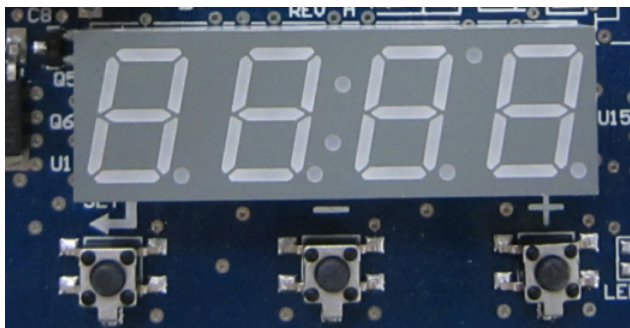

The ECM engine board contains a four-digit, seven-segment display that is used to present information in a format close to real-world language, while having a small-form factor. Most characters are immediately recognizable; however, refer

Table 3 and Table 4 for the graphical representation of each alphanumeric character.

Table 3. Screen representation of alphabetical characters

A	B	C	D	E	F	G	H	I	J	K	L	M
D	E	F	G	H	I	J	K	L	M	N	O	P
N	O	P	Q	R	S	T	U	V	W	X	Y	Z
Q	R	S	T	U	V	W	X	Y	Z	[\]

Table 4. Screen representation of numeric characters

1	2	3	4	5	6	7	8	9	0
4	5	6	7	8	9	:	;	<	3

Note: Characters on the ECM engine board display appear in red, on a black background.

The display contains decimal positions as well that change position with each parameter, as appropriate. Under normal conditions (i.e., with no error code displayed), the status will loop the following message:

RPM Mode

RUNNING/ FAN STATUS CONTINUOUS LOOP

Displayed when:

- 1) No error codes are present.
- 2) Motor has completed ramping.

<p>pwu4</p> <p>3333 → 5333</p>	<p>Indicates the current rpm of Motor 1 in the system. 0 rpm here indicate that no fan speed has been requested.</p>
<p>pwu5</p> <p>3333 → 5333</p>	<p>Indicates the current rpm of Motor 2 in the system. 0 rpm here indicate a fan off condition OR a fan missing condition^(a).</p>
<p>Ivw4</p> <p> hv / qr</p>	<p>Indicates the status being calculated or Fan Motor 1. If off, this indicates that either:</p> <ol style="list-style-type: none"> 1) No fan speed is being requested or 2) The fan performance is failing to meet the request; refer to “Troubleshooting,” p. 21 for additional information. <p>If on, this indicates that the fan is performing correctly and will be used to report fan status correctly, depending on ISUY mode.</p>
<p>Ivw5</p> <p> hv / qr</p>	<p>Indicates the status being calculated or Fan Motor 2. If off, this indicates that either:</p> <ol style="list-style-type: none"> 1) No fan speed is being requested or 2) The fan performance is failing to meet the request; refer to “Troubleshooting,” p. 21 for additional information. 3) If the target speed for Motor 2 is 0, this is used to indicate a missing motor^(a). <p>If on, this indicates that the fan is performing correctly and will be used to report fan status correctly, depending on ISUY mode.</p>
<p>HkHq</p> <p>\hv / qr</p>	<p>Indicates that the temperature sensing circuit has calculated a logical on based on the settings of the following parameters:</p> <p>D15p / d15e / d1sx</p>

(a) Motor 1 is the only motor in sizes 200, 300, 400, 600, and 800. Sizes 1000 and 1200 units contain two motors: Motor 1 (single shaft) and Motor 2 (double shaft).

Configuration parameter and value display and modification changes

The ECM engine board’s on-board user interface is easy to use and supports:

1. Verification/auditing of on-board parameter settings (read-only).
2. Adjustment of the on-board settings (write).

Figure 2. User interface input buttons

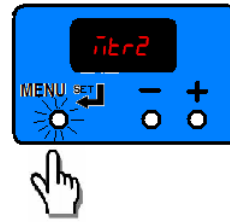

The user interface has three input buttons, from left to right:

1. Menu/Set
2. Decrement
3. Increment

Each button has several different actuation levels depending on length of press, and what the UI is currently displaying.

Table 5. Button actuation levels

Button	Menu/Set	
	Duration	Action
Short Press in Status Display	<1 sec	None
Short Press in Configuration Display		Toggles between parameter name and value without saving (abandons value if changed).
Long Press/Hold in Status Display	>3 sec	Enters the configuration menu
Long Press/Hold in Configuration Display	>3 sec	If on a parameter name, toggles to the value. If on a parameter value, saves the value settings and returns to the parameter name as confirmation.

Button	Decrement	
	Duration	Action
Short Press in Status Display	<1 sec	None
Short Press in Configuration Display	<1 sec	Scrolls through parameter names, or decreases value of parameter.
Long Press/Hold in Status Display	>3 sec	N/A
Long Press/Hold in Configuration Display	>3 sec	Faster scroll through parameter name, or faster decrease of values of parameters.

Button	Increment	
	Duration	Action
Short Press in Status Display	<1 sec	None
Short Press in Configuration Display	<1 sec	Scrolls through parameter names, or increases value of parameter.
Long Press/Hold in Status Display	>3 sec	N/A
Long Press/Hold in Configuration Display	>3 sec	Faster scroll through parameter name, or faster increase of values of parameters.

Configuration Use Examples

Example 1: View the value of parameters without saving
In this example Low Speed Value for Motor 1 is set to 800 rpm.

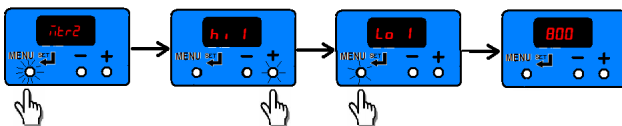

1. Long press **MENU** to enter the Configuration Menu.
2. Use **INCREMENT/DECREMENT** to scroll to the desired parameter.
3. Short press **MENU** to view parameter setting.

Example 2: Change the value of a parameter

In this example the Low Speed Value from Example 1 will be changed to 820 rpm.

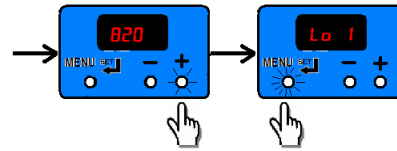

1. Use the steps from Example 1 to select a parameter and view its setting.
2. Use **INCREMENT/DECREMENT** to change the setting of the parameter.
3. Long press **MENU** to save the setting and return to the parameter name.

Example 3: Verify a parameter has been changed.

In this example the change made to Low Speed Value from Example 2 will be verified.

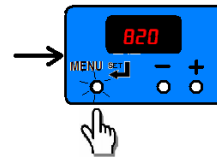

1. Use the steps from Example 1 and Example 2 to select a parameter and change its setting.
2. Short press **MENU** to view new parameter setting.

Parameter List

The following table lists the parameter names and typical settings of the ECM engine board, for reference only.

Note: Maintain a record of all parameter settings in case of controls modification or failure.

Additional Notes

1. This list is applicable only to fan-coil and Force-Flo products.
2. Do NOT change the electric heat protection settings if your unit has electric heat.
3. If the format setting for rpm values are not correct (i.e., not four-digit: XXXX), please check the operation mode of the ECM Engine board **prg4** and **prg 5**.

Configuration Settings of the ECM Engine Board

Description On Unit Label	User Interface		Description	Notes ^(a)
	Name	Typical Value		
<i>Mtr 1 High Spd</i>	Kl 4	43 ; 3	Sets the high speed rpm for Motor 1.	Do not exceed 1700 rpm. Do not set under 450 rpm. On units with two motors, the single shafted motor is designated as Motor 1. If the unit has only one motor, all seven speed settings for the second motor (Kl 5, Pg 5, Or 5, H4P5, H5P5, DOP5, DKP5) should be set to zero. Analog inputs below the yIou setting will be rejected. Note: EXMX settings are locked out on units with electric heat.
<i>Mtr 1 Med Spd</i>	pg 4	:::	Sets the medium speed rpm for Motor 1.	
<i>Mtr 1 Low Spd</i>	or 4	965	Sets the low speed rpm for Motor 1.	
<i>EHStg1 Mtr1 Spd</i>	H4p4	3333	Assigns an rpm to be associated with a call for 1 st stage electric heat, for Motor 1 (only on electric heat equipped units).	
<i>EH Stg 2 Mtr 1 Spd</i>	H5p4	3333	Assigns an rpm to be associated with a call for 2 nd stage electric heat, for Motor 1 (only on electric heat equipped units).	
<i>AI High Spd Mtr 1</i>	dkp4	3333	Sets the maximum rpm for Motor 1 for the maximum input value of the analog input.	
<i>AI Low Spd Mtr 1</i>	dop4	3333	Sets the minimum turn-on rpm for Motor 1, when the analog input becomes active.	
<i>Mtr 2 Hgh Spd</i>	Kl 5	3333	Sets the high speed rpm for Motor 2.	
<i>Mtr 2 Med Spd</i>	Pg 5	3333	Sets the medium speed rpm for Motor 2.	
<i>Mtr 2 Low Spd</i>	Or 5	3333	Sets the low speed rpm for Motor 2.	
<i>EHStg1 Mtr2 Spd</i>	H4p5	3333	Assigns an rpm to be associated with a call for 1 st stage electric heat, for Motor 2 (only on electric heat equipped units).	
<i>EH Stg 2 Mtr 2 Spd</i>	H5p5	3333	Assigns an rpm to be associated with a call for 2 nd stage electric heat, for Motor 2 (only on electric heat equipped units).	
<i>AI High Spd Mtr 2</i>	dkp5	3333	Sets the maximum rpm for Motor 2 for the maximum input value of the analog input.	
<i>AI Low Spd Mtr 2</i>	dop5	3333	Sets the minimum turn-on rpm for Motor 2, when the analog input becomes active.	
<i>Op Mode Mtr 1</i>	prg4	usp	Sets the operational mode for Motor 1.	Must be set to RPM for fan coil products.
<i>Op Mode Mtr 2</i>	prg5	usp	Sets the operational mode for Motor 2.	Must be set to RPM for fan coil products.
<i>Mtr 1 Out Format</i>	v1j4	szP	Sets the interface type for Motor 1.	Must be set to PWM for fan coil products.
<i>Mtr 2 Out Format</i>	v1j5	szP	Sets the interface type for Motor 2.	Must be set to PWM for fan coil products.
<i>Mtr 1/2 PWM Freq.</i>	iuht	433	Sets the PWM frequency, for cases when the PWM outputs are used.	On fan coil units, the PWM must not be changed.
<i>Mtr 1 PWM Volt</i>	P4yo	8133	Sets the PWM voltage, for cases when the PWM outputs are used.	This setting must not be changed, as damage to the motor may occur!
<i>Mtr 2 PWM Volt</i>	P5yo	8133	Sets the PWM voltage, for cases when the PWM outputs are used.	This setting must not be changed, as damage to the motor may occur!
<i>Mt1 Hgh PWM Lt</i>	P4k1	:3133	Sets the maximum output % that the controller will request from Motor 1.	This envelope protection value should not be altered.
<i>Mt1 Low PWM Lt</i>	P4Or	4<183	Sets the minimum maximum output % that the controller will request from Motor 1.	This envelope protection value should not be altered.
<i>Mt2 Hgh PWM Lt</i>	P5k1	:3133	Sets the maximum output % that the controller will request from Motor 2.	This envelope protection value should not be altered.
<i>Mt2 Low PWM Lt</i>	P5Or	4<183	Sets the minimum maximum output % that the controller will request from Motor 2.	This envelope protection value should not be altered.
<i>Mt1 Ovspd RPM</i>	usp4	6333	Selects the rpm above which the Motor 1 will be assumed to be in an overspeed condition and will need to be shut down.	This envelope protection value should not be altered.
<i>Mt2 Ovspd RPM</i>	usp5	6333	Selects the rpm above which the Motor 2 will be assumed to be in an overspeed condition and will need to be shut down.	This envelope protection value should not be altered.
<i>Fan Proving Fct</i>	ISuy	Iqvw	Selects which mode should be assigned to the Binary output circuit, depending on unit type.	This setting has to be correct for proper unit operation of electric heat and changeover units.
<i>AI Boost Amp</i>	D1Vf	34133	Boosts or attenuates the analog input signal to compensate for long wire runs.	



Controls Configuration

Description On Unit Label	User Interface		Description	Notes ^(a)
	Name	Typical Value		
<i>AI Floor</i>	yIou	31633	Rejects noise on the analog input lines and sets up the engine board to turn on if the thermostat or controller is commanding its analog outputs on.	
<i>PulsePerRev</i>	Igen	45133	Sets up the tachometer function to be compatible with the on-board motor.	Do not change this setting as this is critical to proper unit operation.
<i>P Value Mtr 1</i>	syo4	31363	Sets up the on board closed loop control to control the Motor 1 with proper stability.	Do not change this setting.
<i>I Value Mtr 1</i>	Lyo4	31363	Sets up the on board closed loop control to control the Motor 1 with proper stability.	Do not change this setting.
<i>P Value Mtr 2</i>	syo5	31363	Sets up the on board closed loop control to control the Motor 2 with proper stability.	Do not change this setting.
<i>I Value Mtr 2</i>	Lyo5	31363	Sets up the on board closed loop control to control the Motor 2 with proper stability.	Do not change this setting.
<i>Ht Sens Mk Val F</i>	Dl5p	;8133	Sets the make value for the thermistor input.	
<i>Ht Sens Bk Val F</i>	Dl5e	<3133	Sets the break value for the thermistor input.	
<i>Ht Sens Resistor</i>	DlSx	rxw	Sets the input impedance of the thermistor input.	Should be pre-set to OUT for Tracer ZN controllers.
<i>Mt 1 Ramp %/sec</i>	P4us	36133	Sets the ramp rate for Motor 1, in % per second.	
<i>Mt 2 Ramp %/sec</i>	p5us	36133	Sets the ramp rate for Motor 2, in % per second.	
<i>EH Rmp Accel</i>	Hkus	81333	Sets the acceleration factor for the electric heat inputs.	Is used to force faster ramps when electric heat is requested.
<i>Ramp MAX Time</i>	Pkus	3348	Sets the maximum ramp time for both Motor 1 and Motor 2.	
<i>EH Fan off delay</i>	HKgo	33133	Selects how long the fan needs to stay on after an electric heat request has been turned off.	Not used on fan coil unit.
<i>Lck Rtr Protect</i>	Ousw	rq	Selects whether to use the on-board locked rotor protection function.	This will shut down the affected motor, if response is not detected.
<i>Protect Funct</i>	Hksw	rq	This function protects settings on the board that affect the safety of the electric heat system	Do not change this setting. This setting locks out the following parameters from being changed, for safe operation of the unit. DlSX ISuy DlPN DlEN H4P4 H4P5 H5P4 H5P5 V1j Prg4 Prg5 P4K1 j P4Or
<i>Rmp dft (auto rst)</i>	usgi	rii	This function shortens the ramps for faster unit commissioning and auto-resets to off.	
<i>Soft Rev</i>	vriw	y4164	Displays the software version.	

(a) These notes are provided for reference only.



Troubleshooting

⚠ WARNING

Safety Alert!

You **MUST** follow all recommendations below. Failure to do so could result in death or serious injury or property damage.

- The Universal Adapter Modules as well as other components in the control box contain high voltage. While configuring the ECM engine board, proper PPE is required and care should be taken to avoid touching the other components. Alternatively, power can be removed from the unit and the ECM engine board can be configured using the configuration kit that allows powering of the engine board with a 9V battery.
- The BLDC motors contain capacitors which store residual energy. You **MUST** keep clear of the fan wheels for 5 minutes after the power has been removed from the system, as a power request with the motor powered off, could result in a very short period of actuation. Unplugging the motor is adequate to ensure that there will be no power request.
- Do not make connections to the motors or the adapter boards while power is ON. Do not remove connections to the motor or the adapter boards while the power is ON.
- Do not free spin the fan wheels with your hands while the unit is powered on. The system is constantly scanning and responding to the operational status of the motors.

Priority and Error Codes

⚠ WARNING

Hazardous Service Procedures!

Failure to follow all precautions in this manual and on the tags, stickers, and labels could result in death or serious injury.

Technicians, in order to protect themselves from potential electrical, mechanical, and chemical hazards, **MUST** follow precautions in this manual and on the tags, stickers, and labels, as well as the following instructions: Unless specified otherwise, disconnect all electrical power including remote disconnect and discharge all energy storing devices such as capacitors before servicing. Follow proper lockout/tagout procedures to ensure the power can not be inadvertently energized. When necessary to work with live electrical components, have a qualified licensed electrician or other individual who has been trained in handling live electrical components perform these tasks.

Under normal circumstances, the ECM engine display will display the operational status of the motors. A malfunction will drive a priority display mode that will present the error code instantly to the screen. The error must be cleared by powering down, removing the cause of the problem and restarting the engine board.

Notes:

- *During error displays, the user interface will be disabled, until the error is removed or resolved.*
- *If changes are made to parameters and saved, most settings take effect immediately. Any change to fan speeds will take effect and cause the configuration menu to exit immediately to begin tracking speeds via the on-board tachometer.*
- *Where practical, the unit will offer limp-in performance, but to ensure safe operation, certain unit functions will be disabled. For example, if one motor fails, the unit will display an error code, but the second motor (if present) will continue to operate. For safe operation, the electric heat (if present) will be disabled.*
- *If an error occurs while the configuration menu is in effect, all unsaved values will be discarded and the error codes will be displayed.*

Error Codes: Displayed during abnormal operation.	
Pwu4 ORFN	Indicates a locked rotor condition of Motor 1. The motor will be locked out until the cause has been resolved, and the power cycled. Motor 2 will continue to operate, but will not be monitored. Fan Status function, if being used, will report an inoperative motor. Electric heat and changeover heat will be shut down.
Pwu5 ORFN	Indicates a locked rotor condition of Motor 2. The motor will be locked out until the cause has been resolved, and the power cycled. Motor 1 will continue to operate, but will not be monitored. Fan Status function, if being used, will report an inoperative motor. Electric heat and changeover heat will be shut down.
Pwu4 Rvsg	Indicates that Motor 1 has experienced a run-away or over speed condition, and has been shutdown. The unit will offer limited limp-in performance, and Motor 2 will continue to operate, but will not be monitored. Fan Status function, if being used, will report an inoperative motor. The cause must be resolved and the power to the unit cycled, to be reset. Electric heat and changeover heat will be shut down.
Pwu 5 Rvsg	Indicates that Motor 2 has experienced a run-away or over speed condition, and has been shutdown. The unit will offer limited limp-in performance, and Motor 1 will continue to operate, but will not be monitored. Fan Status function, if being used, will report an inoperative motor. The cause must be resolved and the power to the unit cycled, to be reset. Electric heat and changeover heat will be shut down.
Udps 3333 ù 5333 5333 ù 3333	Indicates the motor is transitioning between speeds, ramping up or down. The message RAMP is briefly displayed, followed by the target speed for Motor 1 only. Once the target speed has been reached, the status display will resume operation.
y456	On power on, the version of software is briefly displayed, followed by the results of a POST (power on self test).

Motor Operation

Motor does not spin, or spins too slowly

1. Turn off power to unit.
 - a. Verify that the motor connections and motor plug connections to the adapter boards are secure.
 - b. Verify that Speed Inputs are connected in the correct order if the Speed Inputs are connected to the Universal Adapter Module.
2. Turn on power to unit.
 - a. Verify that the unit is receiving the correct voltage level and polarity.

⚠ WARNING

Do Not Reverse Polarity!

Failure to follow instruction could result in death or serious injury, and equipment damage. Reversing the polarity to the BLDC controls could result in a direct line to ground fault, thus exposing technicians to hazardous live voltage.

3. When configured correctly, the system will always respond positively to direct, indirect and conflicting speed requests with very few exceptions.

These exceptions are:

- a. If a motor has been locked out due to engine locked rotor protection.

Assuming **Pwu4** has an obstruction. In this case the Status Display will be interrupted to display:

OUSW → Pwu4 → OUSW

Solution:

- i. Remove obstruction from the fan wheel.
- ii. Ensure that motor plugs and all plugs to adapter boards and the ECM engine board are secure
- iii. Verify that the configuration does not specify a motor that is physically missing. Most units require only one motor. The controller is made aware of the missing motor by specifying all speeds related to **Pwu5** to 0 rpm.

- b. If a motor has been locked out due to overspeed or runaway condition:

Assuming **Pwu4** has an overspeed condition. In this case the Status Display will be interrupted to display:

Rvsg → Pwu4 → Rvsg

Solution:

- i. Ensure that set-screw is attached firmly to the motor shaft.
- ii. Ensure that motor plugs and all plugs to adapter boards and the ECM engine board are secure.

- iii. Verify that the configuration does not specify a speed lower than 450 rpm for the affected motor. Speeds below 450 rpm are not supported on fan-coil units.

Motor spins too fast, or spins without any apparent speed request

Typical equipment and controls design practice will ensure that the fans will come on if there is a call for heat, cool, or ventilation. In most cases the motor will depend on the controller/thermostat to call for the fan to come on when appropriate.

Calls for electric heat are also treated as a call for the appropriate fan speed. This behavior is known as an indirect request. When a call for electric heat is made, the system will positively drive the fan on to the correct speed, regardless of whether the controller has asked for fan operation or not. The unit does not lock out electric heat if the fan is set to off. Instead, it will bring the fan on.

Note: *In many cases, indirect requests will result in fan behavior change regardless of whether the end-device fails to actuate (due to device failure, or safety / downstream lockouts).*

If the preceding conditions do not describe the behavior of the unit, the following checks should be performed:

NOTICE

Equipment Damage!

The voltage jumper on the motor plug harness must be removed for 208/230V units and 277V units. If the jumper is present for these units, the motor electronics will be damaged, and the motor will not be controllable.

1. Verify that the voltage jumper on the motor plug harness is absent for 208/230V units and 277V units.
2. Turn off power to unit.
 - a. Verify Speed Inputs are connected in the correct order if the Speed Inputs are connected to the Universal Adapter Module individually rather than through the factory installed motor plug.
3. Turn on power to unit.
 - a. Verify that the fan speed request is not below 450 rpm. Speeds below 450 rpm are not supported on fan-coil units.

Motor spins in the wrong direction:

Single-shaft Trane Brushless DC Motors are factory configured to rotate clockwise. This direction is set by a jumper internal the motor housing. The rotation direction of double-shaft motors is dictated by mounting orientation.

1. Turn off power to unit and remove the motor.
 - a. For single-shaft motors, refer to “[Motor Rotational Direction](#),” p. 10 for instructions on removal/installation of the rotational direction jumper.
 - b. For double-shaft motors, rotate the motor 180 degrees and reinstall.

Other Unit Functions

In some cases, the normal or abnormal operation of the BLDC system may interact with other components in the system. Verification of the engine and adapter board wiring and configuration should be checked if there are unexplained abnormalities in other areas of the unit:

1. Valve operation
2. Electric heat operation
3. Changeover sensor operation
4. Damper operation
5. Condensate overflow switch

A high degree of protection is provided on electric heat units. If electric heat fails to actuate, it may be because of one of the following events:

- Fans are failing to meet target speed. If a second motor is not present, all settings for speeds for Motor 2 should be set to 3333.
- Hot water may be available in the changeover coil.
- The connection to analogue Input 1 on the Tracer ZN controller may be reversed in polarity.
- Target speeds for motors may be set too high.
 - The **ISUY** parameter may be set incorrectly.
 - The **DLSX** parameter may be set incorrectly.

Trane - by Trane Technologies (NYSE: TT), a global climate innovator - creates comfortable, energy efficient indoor environments for commercial and residential applications. For more information, please visit trane.com or tranetechnologies.com.

Trane has a policy of continuous product and product data improvement and reserves the right to change design and specifications without notice. We are committed to using environmentally conscious print practices.