



# Service Information

File In/With:

S10385

New

518

Equipment Affected: YK MOD G & H, YD, YKEP

Thermal Expansion Valves (TXV) Availability

## BACKGROUND

The older style TXV P/N 025-35133-000 (see figure below) are facing limited in-stock quantity. This older valve can still be purchased from the Baltimore Parts Distribution Center. If the P/N 025-35133-000 is no longer available, then Johnson Controls recommends replacing the old TXV with P/N 025-38170-000. (see figure on page 2).

Thermal Expansion Valve (P/N 025-35133-000)

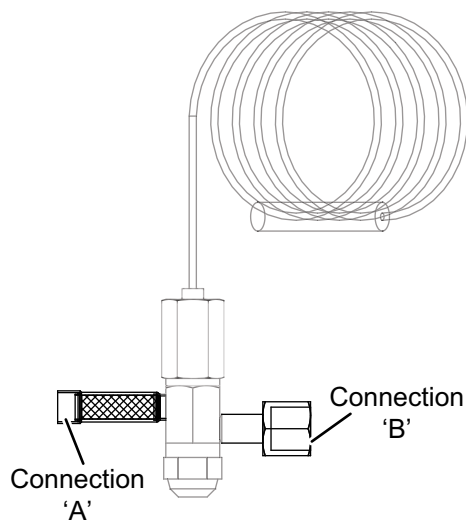

Oil Cooler Connections

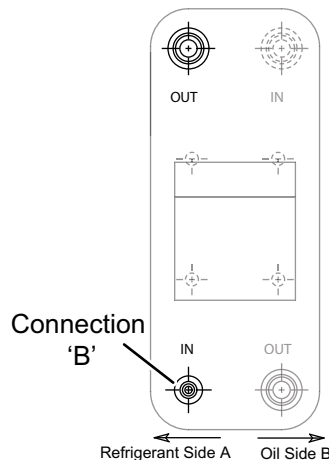

CONNECTION TYPE	DESCRIPTION
Connection A	1/2 inch I.D. Solder joint fitting. Material: Copper.
Connection B	Female Swivel Connection for 1/2 inch tube size. Nut Thread: 13/16-16, dimensions per SAE J1453. Material: Brass.

LD27154

Work on this equipment should only be done by properly trained personnel who are qualified to work on this type of equipment. Failure to comply with this requirement could expose the worker, the equipment and the building and its inhabitants to the risk of injury or property damage.

The instructions on this service bulletin are written assuming the individual who will perform this work is a fully trained HVAC & R journeyman or equivalent, certified in refrigerant handling and recovery techniques, and knowledgeable with regard to electrical lock out/tag out procedures. The individual performing this work should be aware of and comply with all Johnson Controls, national, state and local safety and environmental regulations while carrying out this work. Before attempting to work on any equipment, the individual should be thoroughly familiar with the equipment by reading and understanding the associated service literature applicable to the equipment. If you do not have this literature, you may obtain it by contacting a Johnson Controls Service Office.

Should there be any question concerning any aspect of the tasks outlined in this bulletin, please consult a Johnson Controls Service Office prior to attempting the work. Please be aware that this information may be time sensitive and that Johnson Controls reserves the right to revise this information at any time. Be certain you are working with the latest information.

This TXV upgrade (P/N 025-38170-000) is not a drop-in replacement to the older style valve. Due to numerous oil cooler size connections available in the field, this upgrade may require some connection modifications. Please refer to the drawing below, to determine the connections required for your application and purchase the necessary connections locally. Some brazing may be required when connecting to the oil supply line.

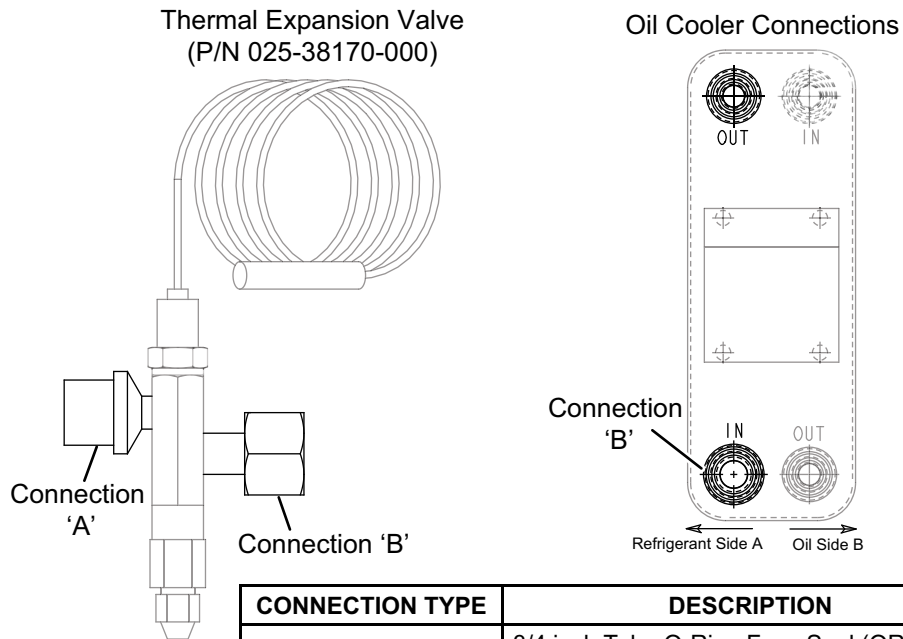

CONNECTION TYPE	DESCRIPTION
Connection A	3/4 inch Tube O-Ring Face Seal (ORFS), 1-3/16-12UN-2A dimensions per SAE J1453. Material: Brass.
Connection B	Female Orifice Swivel Connection for 1 inch tube size. Nut Thread: 1-7/16-12UN-2B, dimensions per SAE J1453. Material: Brass.

LD27153