

**FRS 7../6 NPT Threaded and FRS 5... ISO Flanged  
Gas Appliance Pressure Regulator/Line Pressure Regulator (Class I)  
Installation Instructions**

**SPECIFICATIONS**

**FRS** The FRS series pressure regulator is a spring-loaded pressure regulator with adjustable setpoint spring and an internal sensor for regulating output pressure.

Body sizes	Size	
FRS 705/6	1/2"	NPT
FRS 707/6	3/4"	NPT
FRS 710/6	1"	NPT
FRS 712/6	1 1/4"	NPT
FRS 715/6	1 1/2"	NPT
FRS 720/6	2"	NPT
FRS 725/6	2 1/2"	NPT
FRS 730/6	3"	NPT
FRS 5040	1 1/2"	DN (ISO) Flanged
FRS 5050	2"	DN (ISO) Flanged
FRS 5065	2 1/2"	DN (ISO) Flanged
FRS 5080	3"	DN (ISO) Flanged
FRS 5100	4"	DN (ISO) Flanged
FRS 5125	5"	DN (ISO) Flanged
FRS 5150	6"	DN (ISO) Flanged

**Gases**

Natural gas, propane, butane, air and other inert gases.

**Maximum Operating Pressure**

- 10 PSI (700 mbar) for FRS 7../6 series.
- 7 PSI (700 mbar) for FRS 5...Flanged series.
- 5 PSI (350mbar) applies to the CSA Certification for FRS 7../6 and for FRS 5...Flanged series.

**Output pressure range**

Adjustable with different springs. 1 to 80 in. W.C.

**Materials in contact with gas**

Housing is aluminum and steel free of non-ferrous metals. Seals and diaphragms are NBR.

**Test Port**

Depends on model; see details page 3.

**Maximum pressure drop and gas velocity**

The maximum pressure drop is limited by the velocity of the gas. Do not exceed a gas velocity of 30 meters/s.

**Ambient / Fluid Temperature**

FRS 7../6 series:

- +5 °F to +160 °F for up to 10 PSI for regulating behavior (+/-10% of setpoint).
- -40 °F to +160 °F: Diaphragms are suitable for the low temperature, but there may be out of range regulating behavior.
- CSA Certified for -40 °F to +160 °F.

FRS 5... Flanges series:

- +5 °F to +150 °F (-15 °C to +70 °C) for up to 7 PSI.

**Mounting Position**

Regulator dome vertically upright or lying horizontally.

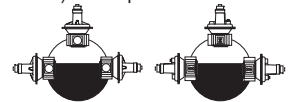

**Vent Limiter and Vent Line Connection**

Vent line connection is G 1/4 thread in accordance to ISO 228. An NPT adapter is available. A vent limiter is factory installed on all FRS's.

**Droop and Hysteresis**

Hysteresis/repeatability is less than 10% for up to 7 PSI inlet. Average droop at 20:1 turndown is 10% for up to 7 PSI.

**Approvals**

- FRS 7../6 series are CSA Certified to ANSI Z21.18/CSA 6.3 & to ANSI Z.21.80/CSA 6.22 as Class I: File No: 1205610.
- FRS 5... series are CSA Certified to ANSI Z21.18/CSA 6.3.
- Commonwealth of Massachusetts Approved Product Approval code G1-1107-35.



**ATTENTION**

- Read these instructions carefully.
- Failure to follow them and/or improper installation may cause explosion, property damage and injuries.
- Installation must be done with the supervision of a licensed burner technician.
- The system must meet all applicable national and local code requirements such as but not limited to NFPA 86, CSD-1, ANSI Z21.13, UL 795, NFPA 85, or CSA B149.3.
- Check the ratings in the specifications to make sure that they are suitable for your application.
- Never perform work if gas pressure or power is applied, or in the presence of an open flame.
- Once installed, perform a complete checkout including leak testing.
- Verify proper operation after servicing.

**MOUNTING PREPARATION**

**Mounting Preparation FRS 7../6 & FRS 5... Flanged**

- The main gas supply must be shut off before starting the installation.
- Read these installation instructions carefully.
- Carefully examine the unit for shipping damage.
- Remove all dirt and debris before installing. Failure to remove dirt/debris could result in damage or improper performance.

# MOUNTING

## Procedure to Mount the FRS 7../6

- Install the FRS../6 with the gas flow matching the direction indicated by the arrows on the casting.
- Mount the FRS../6 with the regulator dome vertical or horizontal.
- Use new, properly reamed and NPT threaded pipe free of chips.
- Apply good quality pipe sealant, putting a moderate amount on the male threads only. If using LP gas, use pipe sealant rated for use with LP gas.
- Do not thread pipe too far. FRS../6 distortion and/or malfunction may result from excess pipe in the valve body.
- Apply counterpressure with a parallel jaw wrench only to the flats of the FRS../6 when installing pipe.

- Do not overtighten the pipe. Follow the maximum torque values listed.
- After installation is complete, perform a leak test using a soapy water solution.
- Install the FRS 5... with the gas flow matching the direction indicated by the arrows on the casting.
- Mount the FRS 5... with the regulator dome vertical or horizontal.
- Insert seal inbetween flanges.
- Insert bolts, tighten in a star pattern to ensure uniform tightness.
- Do not overtighten bolts. Follow the maximum torque values listed.
- After installation is complete, perform a leak test using a soapy water solution

## FRS 7../6 Threaded Series

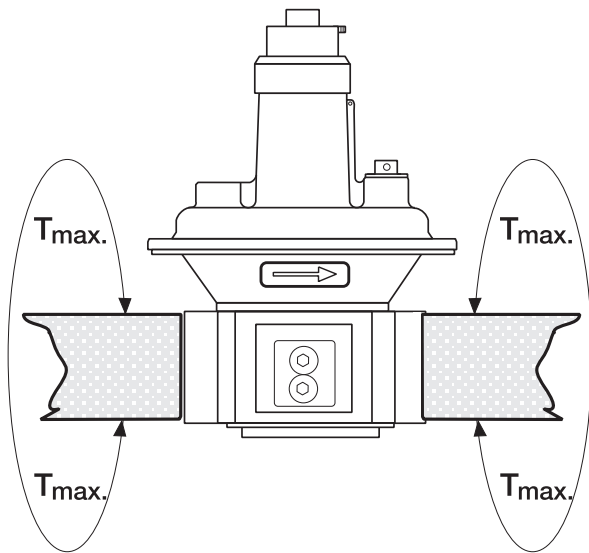

<b>NPT</b>	1/2"	3/4"	1"	1-1/4"	1-1/2"	2"	2 1/2"	3"
<b>Tmax [lb-in]</b>	443	560	750	875	940	1190	1310	1310

**CAUTION:** Do not overtorque threaded connection or bolts permanent damage will occur.

## FRS 5... Flanged Series

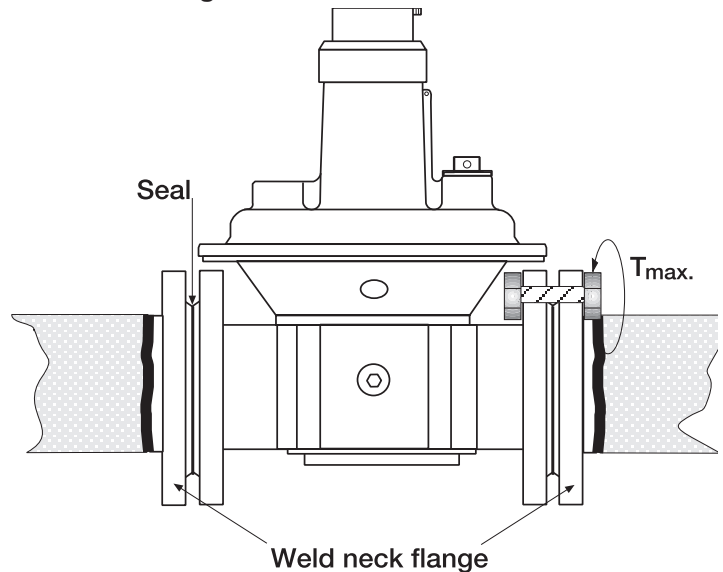

Weld neck flange  
Bolts: as per DIN 939

**Tmax [lb-in]** 443

**CAUTION:** If the flow is not in the same direction as the arrows, the FRS will not operate properly.

## FRS Flange Accessories

Size	Weld neck part #	# of bolts connection	Bolt size	**Bolt part #	***Seal part #
DN ISO 40	227-137	4	M16x55	135-940	100-164
DN ISO 50	227-138	4	M16x55	135-940	030-221
DN ISO 65	227-139	4	M16x65	135-930	099-408
DN ISO 80	227-140	8	M16x65	135-930	030-254
DN ISO 100	227-141	8	M16x65	135-930	030-304
DN ISO 125	227-142	8	M16x75	148-830	030-312
DN ISO 150	227-143	8	M20x80	135-950	030-403
DN 65 to 2 1/2"NPT	243-690	4	M16x65	135-930	099-408
DN 80 to 3"NPT	243-219	8	M16x65	135-930	030-254

\* When a control is used alone, one mating flange is needed for each end, for a total of two flanges. When one control is bolted to another, such as an FRS to a DMV dual modular safety valve, one mating flange is needed for each end, for a total of two flanges

\*\* Includes one bolt, one lock washer, and one nut

\*\*\* One seal needed for each flange

## PRESSURE TAP CONNECTIONS

### Pressure taps

#### FRS 7../6 Threaded

- 1) Vent/breather connection\*.  
FRS 705/6 - FRS 710/6, G 1/4 in.  
FRS 712/6 - FRS 730/6, G 1/2 in.
- 2) External feedback pressure connection. See caution below.  
FRS 705/6 - FRS 710/6, G 1/4 in. - one side.  
FRS 712/6 - FRS 730/6, G 1/4 in. - both sides.
- 3) Upstream pressure connection.  
FRS 705/6 - FRS 710/6, 1/4 in. NPT - one side.  
FRS 705/6 - FRS 710/6, G 1/4 in. - one side.  
FRS 712/6 - FRS 730/6, 1/4 in. NPT - both sides.
- 4) Downstream pressure connection.  
FRS 705/6 - FRS 710/6, 1/4 in. NPT - one side.  
FRS 712/6 - FRS 730/6, 1/4 in. NPT - both sides.

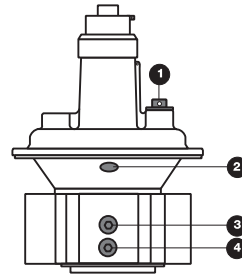

### Pressure taps

#### FRS 5... Flanged

- 1) Vent/breather connection\*.  
FRS 5040 - FRS 5150, G 1/2 in.
- 2) External feedback pressure connection. See caution below.  
FRS 5040 - FRS 5150, G 1/4 in. - both sides
- 3) Upstream pressure connection.  
FRS 5040 - FRS 5150, G 1/4 in. - both sides

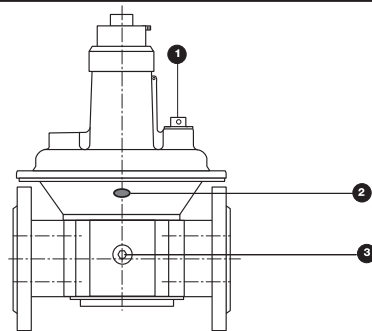

\*All FRS regulators incorporate a factory installed vent limiter that limits the escape of gas to the ambient to less than 0.5 ft<sup>3</sup>/hr in case of diaphragm failure.



**CAUTION:** When using optional external feedback connection, seal the internal impulse connection with a silicone or RTV sealant. Failure to do so will cause the improper outlet pressure regulation.

## BREATHER PLUG

- All FRS's have a breather plug that threads into the regulators's vent connection. DO NOT REMOVE PLASTIC BREATHER PLUG UNLESS VENTING OUTDOORS IS REQUIRED. This plug is not the vent limiter, and it prevents debris from entering the upper chamber of the regulator. Debris in the upper chamber of the regulator will adversely affect regulator performance.
- The FRS regulator must also be able to exchange air through the breather hole in order to properly regulate. Do not plug the breather hole, and clean it out if necessary.

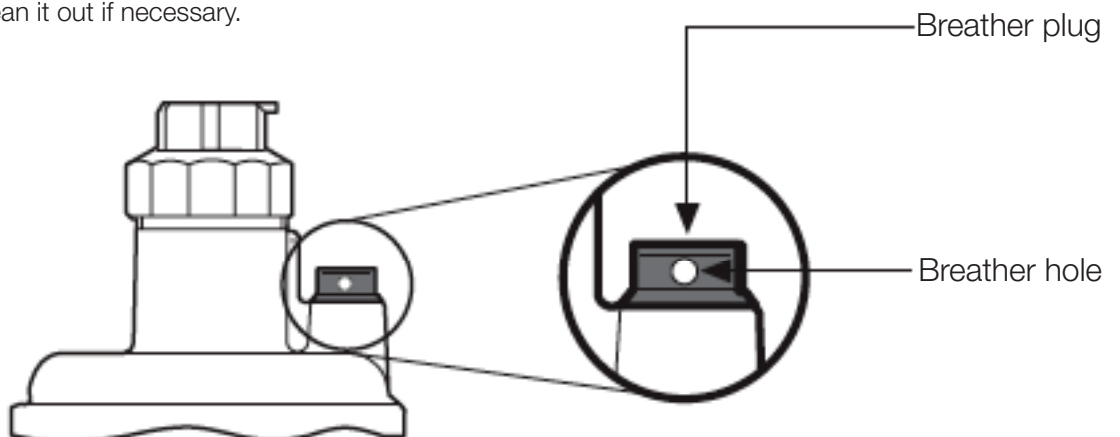

## VENT LIMITER AND VENT LINE CONNECTION

### Vent Limiter

The FRS/6 series regulator contains a factory installed, which limits the escape of gas to less than 0.5 CFH in case diaphragm ruptures. No venting is required when accepted by the authority having jurisdiction.

### Vent Line Requirements

- Follow the local code for vent sizing and termination requirements. In the absence of local codes, follow National Fuel Gas Code NFPA 54 or the International Fuel Gas Code for venting requirements.
- Terminate the vent to an approved location.
- At the point of termination, the vent line must be protected from insects and water intrusion. It is highly recommended to install an insect screen and terminate the pipe with the exit facing downwards to prevent rain water from entering.

### Installation Procedure

- If venting is required, the vent line is to be connected to the upper dome of the FRS regulator as illustrated.
- Remove the beather plug.
- On indoor installations requiring venting outdoors, run the piping as short and as direct as possible.
- The vent connector is G 1/4 for FRS 705/6 to FRS 710/6 and G 1/2 for FRS 712/6 to FRS 730/6 and for all ISO flanged regulators. G 1/4 to 1/4" NPT adapters are available: (part number 231-944) and G 1/2 to 1/2 NPT (part number 231-945).

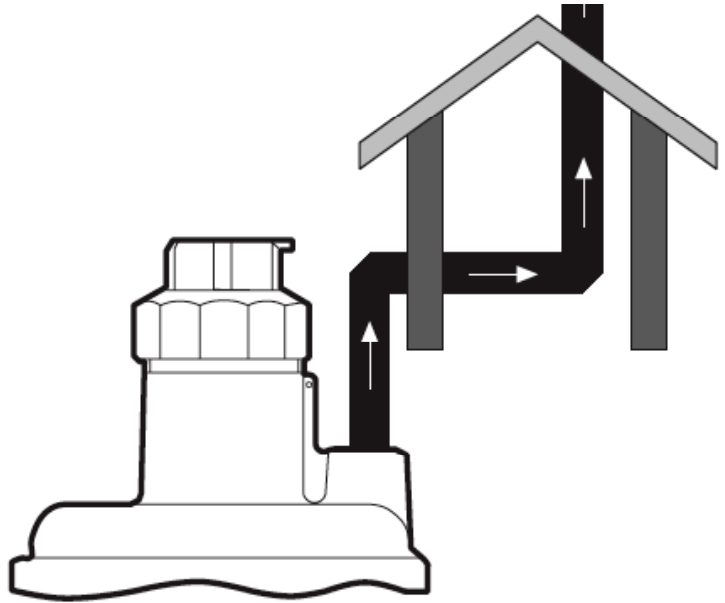

**CAUTION:** In the absence of venting codes and where venting is required, each regulator must be vented separately from all other vents.

## EXTERNAL IMPLUSE

- When it is desirable to use the external impulse as the feedback for the regulator, the internal impulse must be plugged. Seal the internal impulse connection with a silicone or RTV sealant suitable for exposure to natural gas, propane, or butane.
- The external impulse must be properly terminated and made of a durable, metal material that is suitable for gas service.



**The external impulse must terminate back into the gas piping at a point that is upstream two safety shutoff valves in series.**

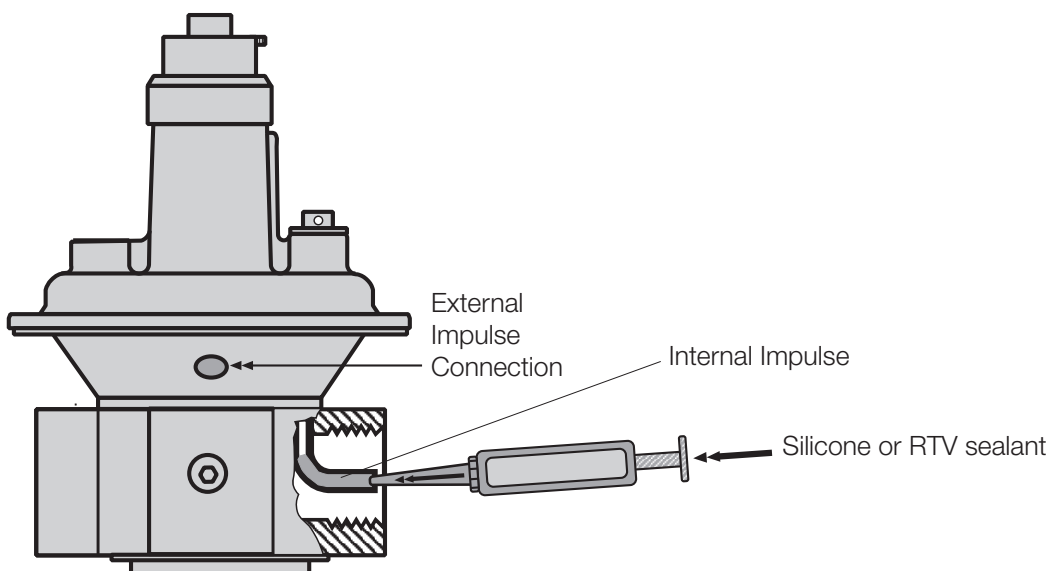

## OUTLET PRESSURE ADJUSTMENT

### Adjusting the FRS outlet pressure

1. Verify that the intended output pressure is within the spring range that is installed in the regulator by comparing the colored outlet pressure label with the table on page 6.
2. Remove the black adjustment cover.
3. To increase outlet pressure, turn the adjustment spindle clockwise. To decrease the outlet pressure, turn the adjustment spindle counterclockwise.
4. Always use an accurate pressure gauge connected downstream of the regulator to measure the actual outlet pressure as the FRS is mounted in the operating position.
5. Reinstall the black adjustment cover.
6. To prevent unauthorized adjustment, holes in the black adjustment cover and the side of the regulator can be used to secure a lead seal.

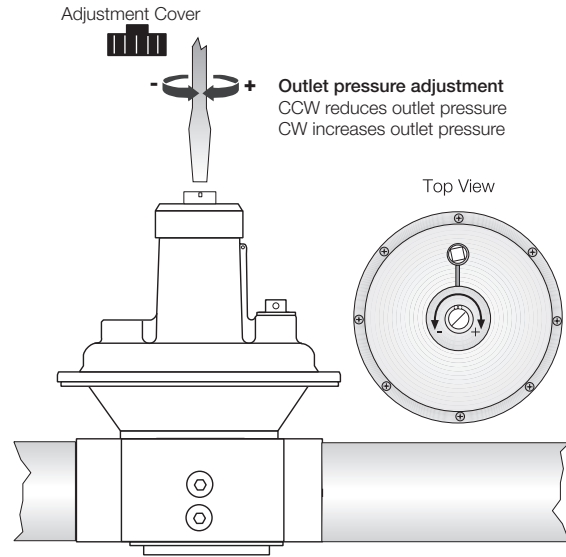

## SPRING REPLACEMENT

### Spring Replacement

- Remove the adjustment cover.
- Completely release the spring tension by turning the adjustment spindle completely counterclockwise with a screwdriver, and remove the aluminum cap.
- Remove existing spring and insert new spring.
- Re-install the adjustment cover, and apply the new outlet pressure label provided with new outlet pressure range onto the name plate.
- Reinstall the adjustment cover.

**⚠ HEAD INJURY RISK: Never have your head above or near the aluminum cap when removing regulator spring. The spring tension can be high enough to rapidly eject the aluminum cap with a large force.**

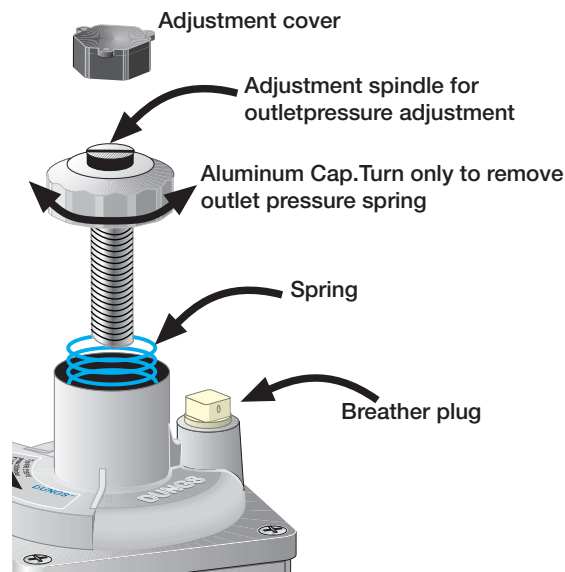

**Outlet Pressure Spring Selection. Values apply to horizontal mount. Subtract 1”W.C. for vertical mount.**

Spring Range (inW.C.) Spring color	1 to 3.6 brown Not CSA	2 to 5 white	2.8 to 8 orange	4 to 12 blue standard	10 to 22 red	12 to 28 yellow	24 to 40 black	40 to 60 pink	60 to 80 grey Not CSA
<b>FRS 705/6</b>	229-817	229-818	229-820	229-821	229-822	229-823	229-824	229-825	229-826
<b>FRS 707/6</b>	229-833	229-834	229-835	229-836	229-837	229-838	229-839	229-840	229-841
<b>FRS 710/6</b>	229-842	229-843	229-844	229-845	229-846	229-847	229-848	229-849	229-850
<b>FRS 712/6, 715/6, 5040</b>	229-851	229-852	229-853	229-854	229-869	229-870	229-871	229-872	229-873
<b>FRS 720/6 &amp; 5050</b>	229-874	229-875	229-876	229-877	229-878	229-879	229-880	229-881	229-882
<b>FRS 725/6, 730/6, 5065, 5080</b>	229-883	229-884	229-885	229-886	229-887	229-888	229-889	229-890	229-891
<b>FRS 5100</b>	229-892	229-893	229-894	229-895	229-896	229-897	229-898	229-899	229-900
<b>FRS 5125</b>	229-901	229-902	229-903	229-904	229-905	229-906	229-907	229-908	243-416
<b>FRS 5150</b>	229-909	229-910	229-911	229-912	229-913	229-914	229-915	229-916	243-417

**REPAIR KITS**

**Repair Kit**                      **Part #**  
(contains all internal hardware to rebuild regulator)

**Repair Kit**                      **Part #**  
(contains all internal hardware to rebuild regulator)

<b>FRS 705/6</b>	Not available
<b>FRS 707/6</b>	Not available
<b>FRS 710/6</b>	Not available
<b>FRS 712/6, 715/6 &amp; 5040</b>	068-924
<b>FRS 720/6 &amp; 5050</b>	068-932

<b>FRS 725/6 &amp; 5065</b>	068-940
<b>FRS 5080 &amp; 730/6</b>	091-868
<b>FRS 5100</b>	091-876
<b>FRS 5125</b>	069-005
<b>FRS 5150</b>	069-013

**FLOW CURVE**

**Natural Gas Flow with FRS in regulated state.**

**Outlet pressure = 4 in. W.C.**

**Inlet pressure = 20 in. W.C.**

**V<sub>min</sub> = 0.05 x V<sub>max</sub>**

**NOTE: Flow tables are available.**

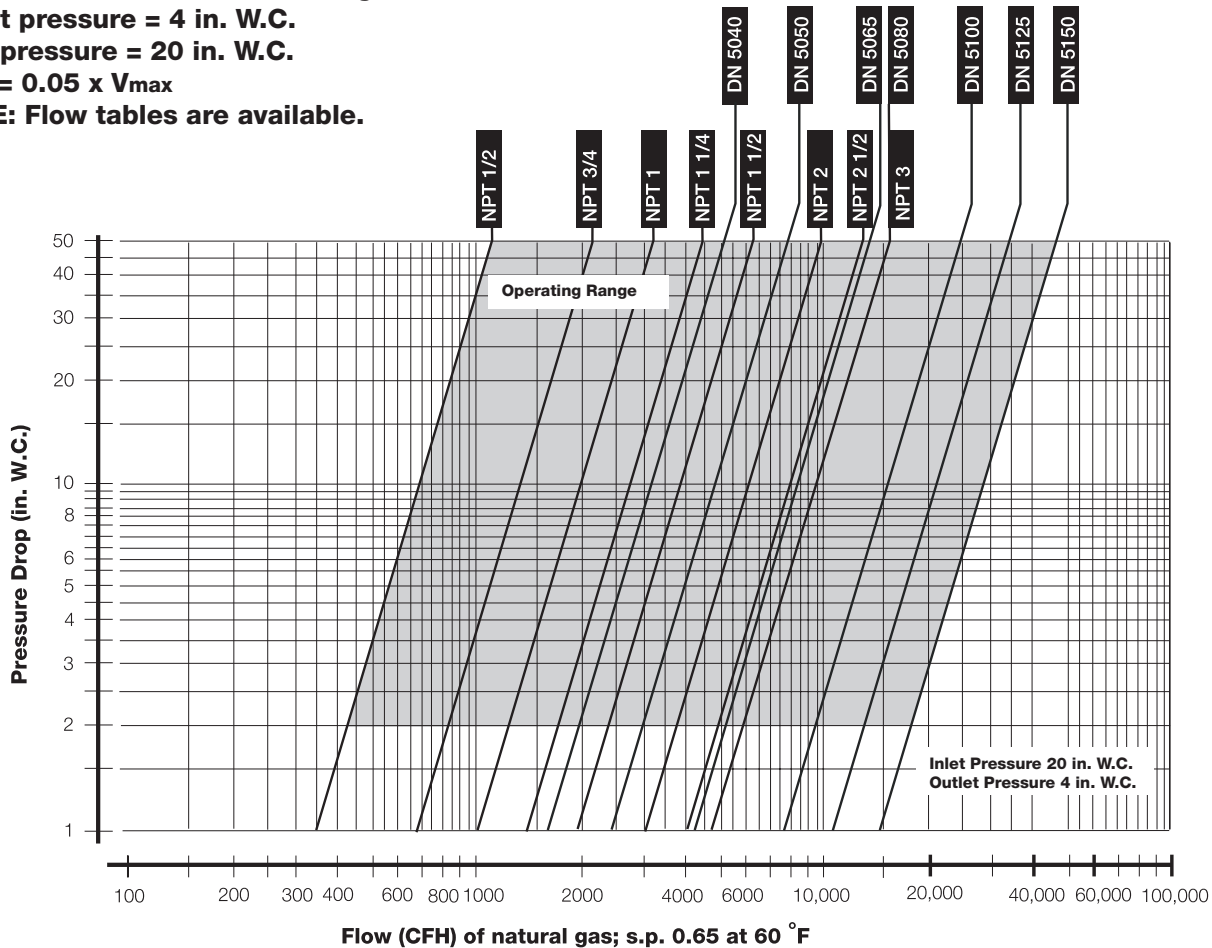

**A minimum of 2 in. W.C. Δp is required when sizing at maximum flow capacity for optimal control.**