

**TJERNLUND PRODUCTS, INC.**

1601 Ninth Street • White Bear Lake, MN 55110-6794  
 PHONE (651) 426-2993 • Technical Assistance (800) 255-4208 • FAX (651) 426-9547  
 Visit our web site • www.tjernlund.com

**MODEL DESCRIPTION**

**\*GPAK-1TR\*: FOR USE ON THE FOLLOWING RHEEM, RUUD, AND WEATHERKING  
 MODEL SERIES FURNACES:**

(-)GDG*	(-)GDJ*	(-)GVH*	(-)GPH*	(-)GLG	(-)GLH*	(-)GVG	(-)GLJ*	(-)GPK*	(-)GLN*
(-)GPJ*	(-)GVJ*	(-)GDC	(-)GLC	(-)GDE	(-)GLE	(-)GVC	(-)GYC	(-)GLK*	(-)GPP*
(-)GVA	(-)GYA	(-)GVB	(-)GYB	WGVAH	WGVAG	WGDAG	WGLAG	(-)GPN*	(-)GPQ*
(-)GLQ*	(-)GPR*	(-)GLR*	80PS*	80LS*					

\*Indicated models are CSA certified with the \*GPAK-1TR\* as a vent system.

**▲ WARNING**

INDICATED 45,000 AND 67,500 BTU FURNACES MUST NOT BE AUXILIARY POWER VENTED UNLESS THE ORIGINAL VENT PRESSURE SWITCH IS REPLACED WITH A .30 VENT PRESSURE SWITCH, PART NO. 42-24064-01. FAILURE TO REPLACE THE PRESSURE SWITCH AS SPECIFIED COULD LEAD TO IMPROPER OPERATION OF THE FURNACE RESULTING IN PROPERTY DAMAGE, PERSONAL INJURY OR DEATH.

**THE MODEL \*GPAK-1TR\* KIT INCLUDES:**

- 1 - POWER VENTER
- 1 - VENT HOOD
- 1 - 4" BAROMETRIC DRAFT CONTROL

**OWNER INSTRUCTIONS, DO NOT DESTROY**

**▲** Recognize this symbol as an indication of important Safety Information!

**NOTE: FLUE GAS TEMPERATURES MUST NOT EXCEED  
 600°F AT POWER VENTER INLET.**

**▲ WARNING**

THESE INSTRUCTIONS ARE INTENDED AS AN AID TO QUALIFIED, LICENSED SERVICE PERSONNEL FOR PROPER INSTALLATION, ADJUSTMENT AND OPERATION OF THIS UNIT. READ THESE INSTRUCTIONS THOROUGHLY BEFORE ATTEMPTING INSTALLATION OR OPERATION. FAILURE TO FOLLOW THESE INSTRUCTIONS MAY RESULT IN IMPROPER INSTALLATION, ADJUSTMENT, SERVICE OR MAINTENANCE POSSIBLY RESULTING IN FIRE, ELECTRICAL SHOCK, CARBON MONOXIDE POISONING, EXPLOSION, PERSONAL INJURY OR PROPERTY DAMAGE.

**DO NOT DESTROY. PLEASE READ CAREFULLY AND  
 KEEP IN A SAFE PLACE FOR FUTURE REFERENCE.**

**TABLE OF CONTENTS**

	PAGE(S)
*GPAK-1TR* DESCRIPTION .....	1
SPECIFICATIONS .....	1
*GPAK-1TR* SIZING .....	2
INSTALLATION RESTRICTIONS .....	2, 3
INSTALLER NOTES .....	3, 4
VENT HOOD LOCATION & INSTALLATION .....	4, 5
POWER VENTER INSTALLATION .....	5, 6, 7
ELECTRICAL WIRING .....	7, 8
INSTALLATION RESTRICTIONS .....	7, 8
SEQUENCE OF OPERATION .....	8
WIRING DIAGRAM .....	8
OPERATION CIRCUIT CHECK .....	9
COMBUSTION AIR .....	9
DRAFT ADJUSTMENT, SAFETY INTERLOCK & COMBUSTION AIR TEST .....	9
MAINTENANCE .....	9
TROUBLESHOOTING .....	10, 11
WARRANTY & REPLACEMENT PARTS .....	11, 12
PERFORMANCE CURVE .....	12
INSTALLER NOTES .....	13
VENT HOOD MOUNTING TEMPLATE .....	14

**\*GPAK-1TR\* DESCRIPTION**

The \*GPAK-1TR\* is a complete venting system designed to side wall vent, Natural and LP gas furnaces. Each \*GPAK-1TR\* comes with three major components: Power Venter, Vent Hood and Draft Control. The \*GPAK-1TR\* can handle a maximum BTU/HR input of 150,000. The "T" of the \*GPAK-1TR\* indicates these kits have a post purge Relay/Timer which allows the Power Venter to continue operating for a nonadjustable period of approximately 45 seconds after the furnace burner shuts off.

**SPECIFICATIONS**

**ELECTRICAL SPECIFICATIONS**

MOTOR VOLTAGE	CONTROL CIRCUIT VOLTAGE	HZ	RPM	WATTS	AMPS	THERMAL PROTECTION
115V	24V	60	3000	95	1.26	YES

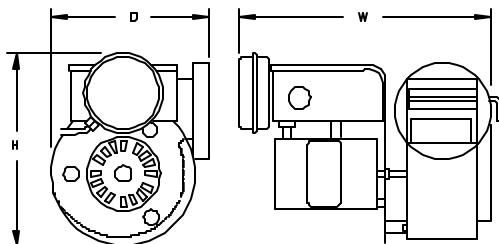

**POWER VENTER**

UNIT DIMENSIONS (IN)				
MODEL	(H) HEIGHT	(W) WIDTH	(D) DEPTH	INLET/OUTLET
*GPAK-1TR*	7 7/8"	11"	7"	4"

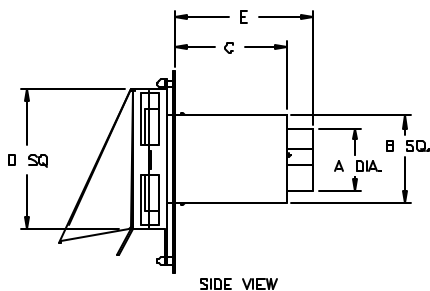

**VENT HOOD**

MODEL	DIMENSIONS					ROUGH-IN DIMENSIONS
	A DIA.	B SQ.	C	D SQ.	E	
VH1-4	4"	7 5/8"	7 1/8"	9"	8 5/8"	8"

## \*GPAK-1TR\* SIZING

Verify that the \*GPAK-1TR\* you are about to install is properly applied to the furnace.

When installing the \*GPAK-1TR\*, confirm that the BTU input of the furnace is 150,000 or less. All BTU/hr. capacity ranges are based on a maximum of 30 linear feet of vent pipe with no more than 3 elbows. All furnaces have a 3" flue connection as shipped from the factory. Use 4" pipe and use a 3" to 4" transition at the furnace.

**WARNING:** NO 34 INCH 80+ FURNACES WITH 45,000 OR 67,500 BTU INPUT CAN BE USED WITH ANY AUXILIARY POWER VENTER UNLESS THE FURNACE'S ORIGINAL 0.10 W.C. PRESSURE SWITCH, (PART NUMBER 42-24064-03) IS REPLACED WITH A 0.30 W.C. PRESSURE SWITCH, (PART NUMBER 42-24064-01).

1. All vent materials located between the furnace and the power venter inlet must be type "B" double wall vent pipe.
2. Single wall reducer(s) may be used to connect a barometric damper to the double wall vent pipe.
3. If the power venter is not directly connected to the inlet of the Power Venter Vent Hood, a sealed vent pipe must be used between the power venter outlet and the vent hood inlet. SEE \*GPAK-1TR\* POWER VENTER INSTALLATION AND OPERATION INSTRUCTIONS FOR ADDITIONAL INFORMATION.

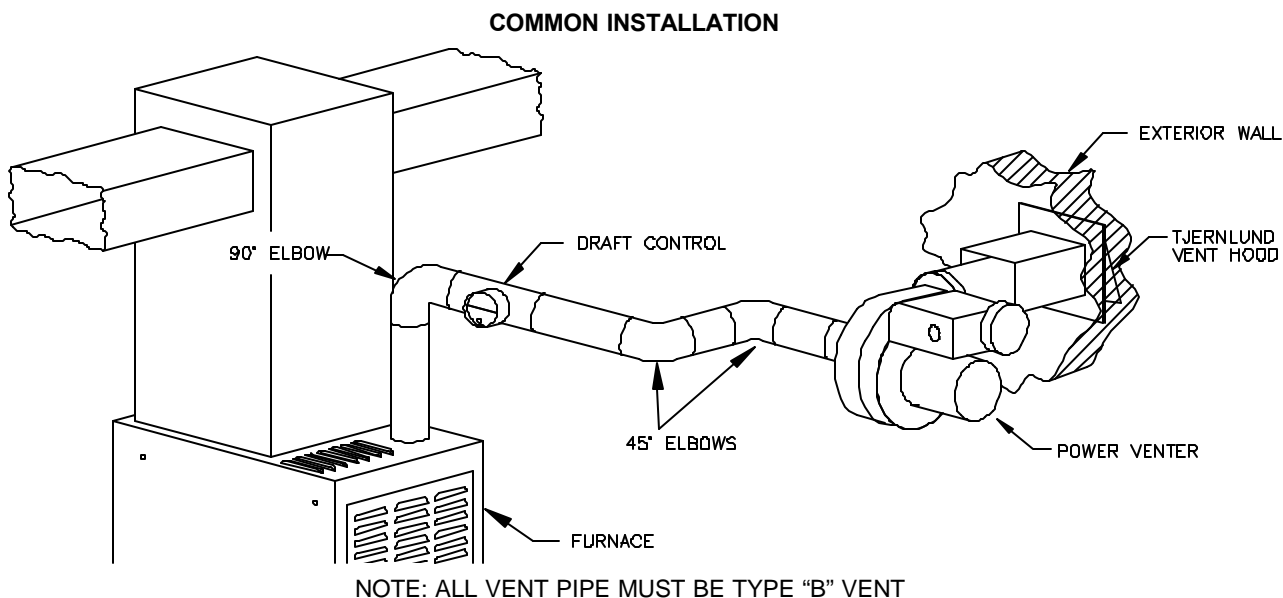

## INSTALLATION RESTRICTIONS

Do not install the Power Venter on an appliance with an automatic valve having a manual opener unless the manual opener has been rendered inoperative or the automatic valve has been replaced with a valve not equipped with a manual opener.

**IMPORTANT:** UNDER NO CIRCUMSTANCES CAN ANY STANDING PILOT FURNACE BE HORIZONTALLY VENTED.  
UNDER NO CIRCUMSTANCES CAN A FURNACE EQUIPPED WITH A NATURAL DRAFT DIVERTER BE HORIZONTALLY VENTED.

### **WARNING**

Failure to install, maintain and/or operate the Power Venter in accordance with manufacturer's instructions may result in conditions which can produce bodily injury and property damage.

### **WARNING**

The Power Venter must be installed by a qualified installer in accordance with these instructions and all local codes or in their absence in accordance with the latest edition of The National Fuel Gas Code (NFPA #54), The latest edition of the National Electrical Code (NFPA#70) and the Occupational Safety and Health Act (OSHA) when applicable. Canadian installations must be installed in accordance with CAN/CGA-B149 and the Canadian Electrical Code Part-1CSA Standard C22.1, Local installation codes and authorities having jurisdiction. Improper installation can create a hazardous condition such as an explosion, fire, electrical shock or carbon monoxide poisoning resulting in property damage, personal injury or death.

### **WARNING**

Flue gas temperatures must not exceed 600 degrees F. at the Power Venter inlet. Ambient temperatures must not exceed 104 degrees F. Temperatures above this range can cause a fire resulting in property damage, personal injury or death.

## **WARNING**

Disconnect the power supply when making wiring connections or when working around the fan wheel and motor. Failure to do so can result in electrical shock, personal injury, death or property damage.

1. "Qualified Installer" shall mean an individual properly trained and licensed
2. The installer must write or imprint name, phone number, date of installation and sign in the appropriate space on the Power Venter nameplate.
3. All vent pipe must be Type "B". Plan the vent system so that Code required distances are maintained from plumbing and wiring.
4. The Power Venter motor shaft must be mounted horizontally to ensure proper operation of the Fan Proving Switch and prevent motor bearing wear.
5. Make certain the power supply is adequate for the fan motor requirements. Do not add the Power Venter to a circuit where the total load is unknown.
6. The installer must verify that the BTU/hr. input of the appliance does not exceed the recommended input of the \*GPAK-1TR\*. See "\*\*GPAK-1TR\* SIZING" on page 2 of these instructions for sizing information.
7. A safety inspection of an existing appliance must be performed before installation of the \*GPAK-1TR\* as outlined below from ANSI Z223.1/NFPA #54, Appendix H.

### **WARNING**

Improper installation, adjustment, alterations, service or maintenance can cause injury or property damage. Refer to this manual. For assistance or additional information consult a qualified installer, service agency or the gas supplier.

## **\*SAFETY INSPECTION OF A PREVIOUSLY USED GAS APPLIANCE**

(Perform prior to \*GPAK-1TR\* installation)

The following procedure is intended as a guide to aid in determining that an appliance is properly installed and is in safe condition for continuing use.

The following procedure is based on central specified gas furnace installations and it should be recognized that generalized procedures cannot anticipate all situations. Accordingly, in some cases deviation from this procedure may be necessary to determine safe operation of the equipment.

- a. Perform this procedure prior to any attempt at modifications of the furnace or installation of the \*GPAK-1TR\*.
- b. If it is determined there is a condition which could result in unsafe operation, shut off the appliance and advise the owner of the unsafe condition.

Follow the steps below in making the safety inspection:

1. Conduct a gas leakage test of the furnace piping and control system downstream of the gas supply valve in the supply line to the furnace.
2. Visually inspect the venting system and determine there is no blockage or restriction, leakage, corrosion and other deficiencies which could cause an unsafe condition. Correct all deficiencies before installation of the \*GPAK-1TR\*.
3. Shut off all gas to the appliance(s).
4. Inspect burners and crossover's for blockage and corrosion.
5. Inspect heat exchanger for cracks, openings or excessive corrosion. Check both the limit control and fan control for proper operation.

\* Excerpts from the National Fuel Gas Code (ANSI Z223.1/NFPA #54), Appendix H.

## **INSTALLER NOTES**

1. Read and follow these instructions carefully to assure proper installation and operation of the \*GPAK-1TR\*.
2. Fill in the required information on the nameplate located on the power venter electrical box cover.

3. Install the furnace on the suction side of the Power Venter.
4. Notify the homeowner of the maintenance required with the use of the product.
5. Verify that the furnace safety controls are in good operating condition before installation of the \*GPAK-1TR\*.
6. No additional appliances may be vented with the furnace by the \*GPAK-1TR\*.
7. The Power Venter must not be installed into any portion of a vent system which serves appliances other than the one vented by the \*GPAK-1TR\*.
8. Shut off all electricity and gas to the furnace using the furnace circuit breaker/fuse for the electricity and turn off gas valve in the supply line to the furnace before installation of the \*GPAK-1TR\*.
9. Check the limit and fan control for proper operation. Limit control operation can be checked by blocking the circulating air inlet or temporarily disconnecting the electrical supply to the blower motor and determining that the limit control acts to shut off the main burner gas.

## VENT HOOD LOCATION

If possible, locate the Vent Hood on a wall that does not face the direction of prevailing winds. This will diminish the possibility of furnace interruption during periods of extreme winds.

If possible, locate the Vent Hood no closer than 3 feet from an inside corner of an L-shaped structure.

## CODE REQUIREMENTS

Terminate the vent system so that proper minimum clearances are maintained as cited in the latest edition of the National Fuel Gas Code (NFPA # 54) and the latest edition of NFPA #211, as follows:

- Not be less than 7 feet above grade when located adjacent to public walk ways.
- At least 3 feet above any forced air inlet located within 10 feet.
- At least 4 feet below, 4 feet horizontally from or 1 foot above any door, window or gravity air inlet into any building.
- At least 12 inches above grade.
- Ensure flue gas termination is not directed so as to jeopardize people, overheat combustible structures or enter buildings.
- Not less than 2 feet from an adjacent building.
- The vent shall not terminate over public walkways or over an area where condensation or vapor could create a nuisance or hazard.
- Caulk all cracks, seams and joints within 6 feet horizontally and above and below vent.

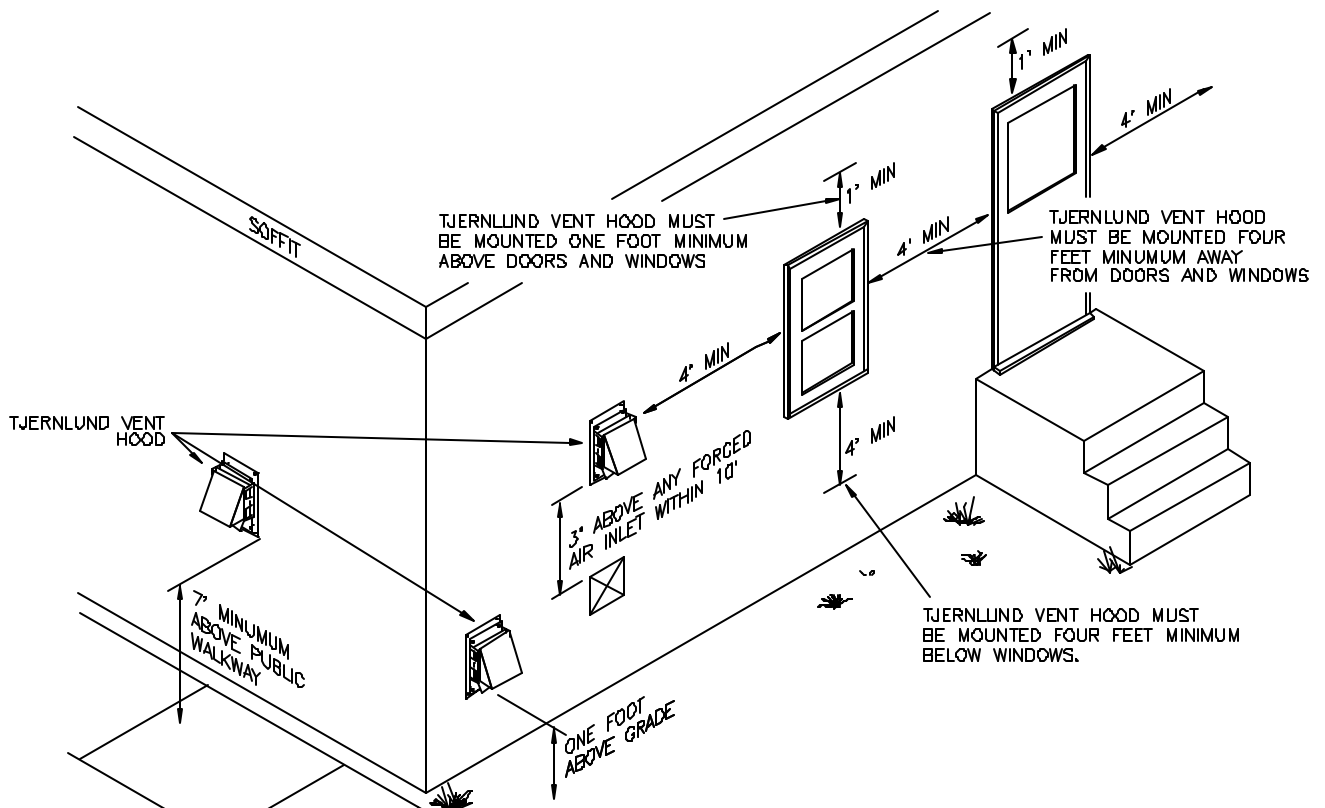

## VENT HOOD INSTALLATION

1. Attach the Vent Hood template (Page 14) to the interior of the wall the vent hood will be penetrating.
2. Ensure that proposed vent termination clearances are met before attempting to cut opening through exterior wall.
3. Verify that wall penetration will not come in contact with concealed wiring or plumbing. Using a 1/2" drill bit, drill two pilot holes where noted on the template. The drill bit must be long enough to penetrate to the building exterior.
4. Attach the template to the building exterior aligning the pilot holes on the template with the pilot holes drilled in step 3.
5. Using a reciprocating saw, cut an opening through the building siding, wall board, etc., following the appropriate lines of the template.
6. Slide the vent hood through the opening and fasten to exterior wall using provided screws.
7. Once Power Venter and vent pipe is completely installed and secured, apply a bead of caulk between Vent Hood flange and exterior of building.

## POWER VENTER INSTALLATION

### CODE REQUIREMENTS

The Power Venter installation must be done in accordance with the following requirements from the latest Edition of the National Fuel Gas Code (NFPA #54):

- Design and install All portions of the vent system under positive pressure during operation (on the outlet side of Power Venter) so as to prevent leakage of flue or vent gases into the building,
- The furnace vent must enter the inlet side of the Power Venter.
- Make provision to interlock the appliance(s) to prevent the flow of gas to the main burners when the draft system is not performing so as to satisfy the operating requirements of the equipment for safe performance. (See electrical section of this manual for details.)

### INSTALLER NOTES

1. Use double wall venting materials only.
2. All vent pipe and reducers must be supplied by the installer and are available from your heating wholesaler.
3. The maximum vent length is 30 feet with a maximum of three 90° elbows.
4. All vent pipe and reducers must be supplied by the installer and are available from your heating wholesaler.
5. The Power Venter may be mounted in any position as long as the shaft of the motor remains horizontal, to prevent motor bearing wear and to ensure proper Fan Proving Switch operation, (See Diagram A).

DIAGRAM A

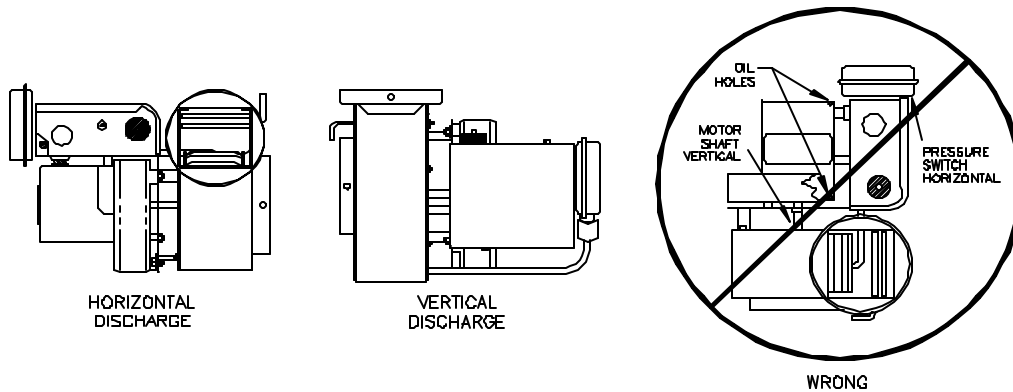

6. All furnaces have a 3" flue connection as shipped from the factory. Use 4" pipe and use a 3" to 4" transition at the furnace.

7. The Power Venter housing is single wall, a 6 inch clearance to combustibles must be maintained, (See Diagram B).

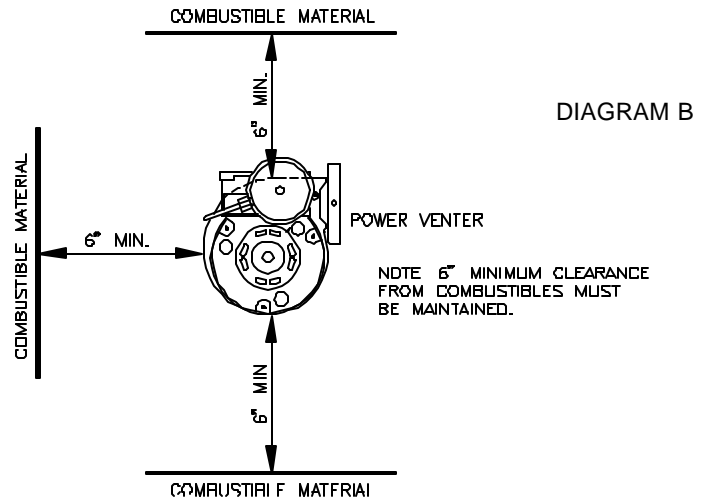

## DRAFT CONTROL INSTALLATION

When installing any \*GPAK-1TR\* Side Wall Venting System on an Induced Draft Furnace a barometric draft control must be added. The draft control provides pressure relief to neutralize over-drafting and allows a means of draft adjustment for optimum furnace efficiency. By adjusting the draft control the installer can obtain the furnace manufacturer's recommended draft setting.

Install the vent pipe and draft control as shown in the diagrams below. The draft control should connect to a tee off of the furnace flue outlet.

The \*GPAK-1TR\* Venting System may only be used with furnaces capable of being chimney vented. It is not suitable for use on high-efficiency, condensing models.

### (UPFLOW FURNACE)

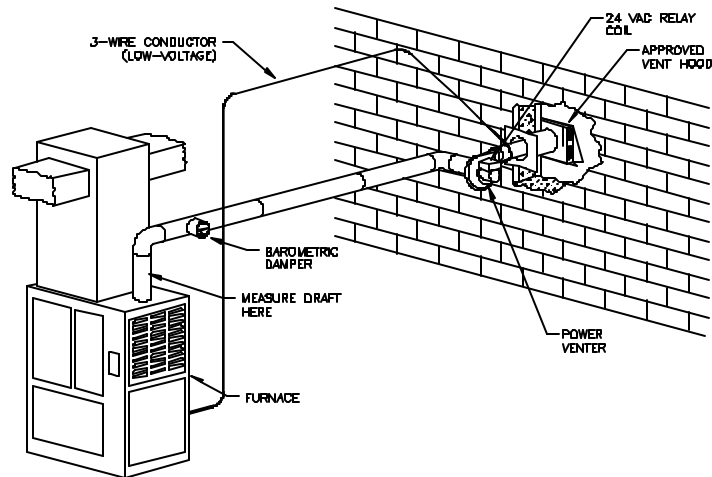

### (HORIZONTAL FURNACE)

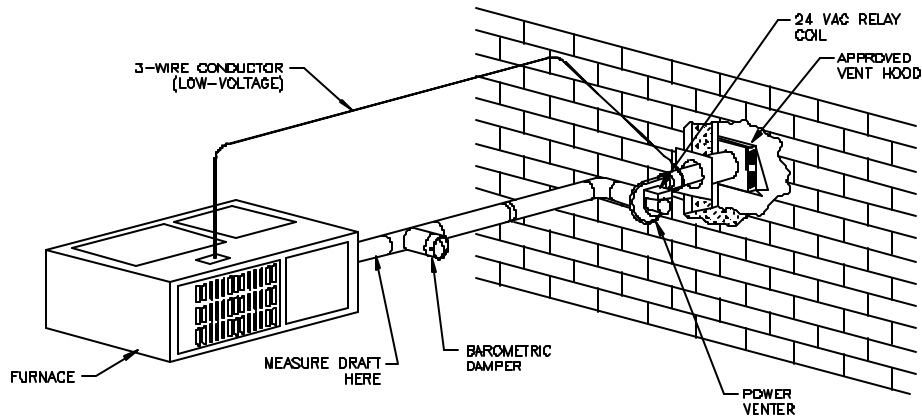

### (DOWNFLOW FURNACE)

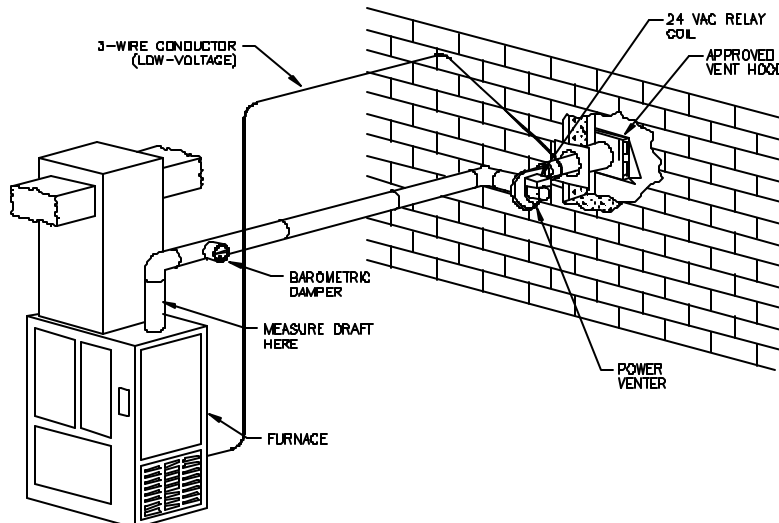

## INSTALLATION (CONTINUED)

- Slide the outlet of the Power Venter over the inlet of the Vent Hood and connect them together using the provided screws, (See Diagram C). If you are unable to make a direct connection to the Vent Hood, vent pipe may be installed between the Power Venter and Vent Hood. However, all vent pipe connections after the Power Venter must be sealed with high temperature silicone caulk or aluminum vent pipe tape to prevent flue gas leakage, (See Diagram D).

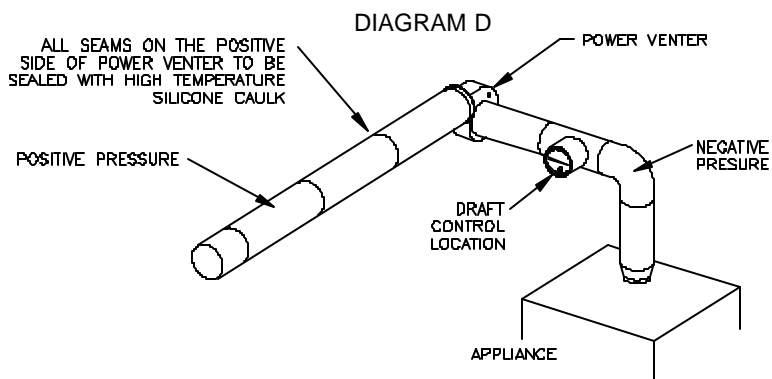
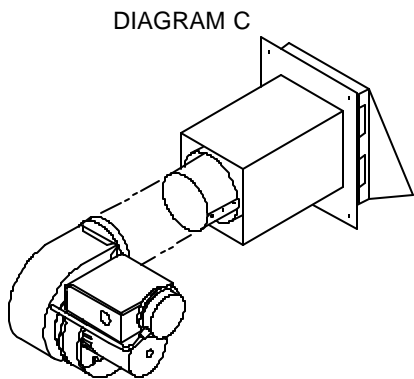

- Temporarily support the Power Venter using wire or a ladder and assemble the mounting brackets, (See Diagram E).
- Install plumbers strap from the Power Venter to the floor joist, (See Diagram E).
- Install 4 inch vent pipe from the Power Venter inlet to the appliance flue outlet avoiding elbows

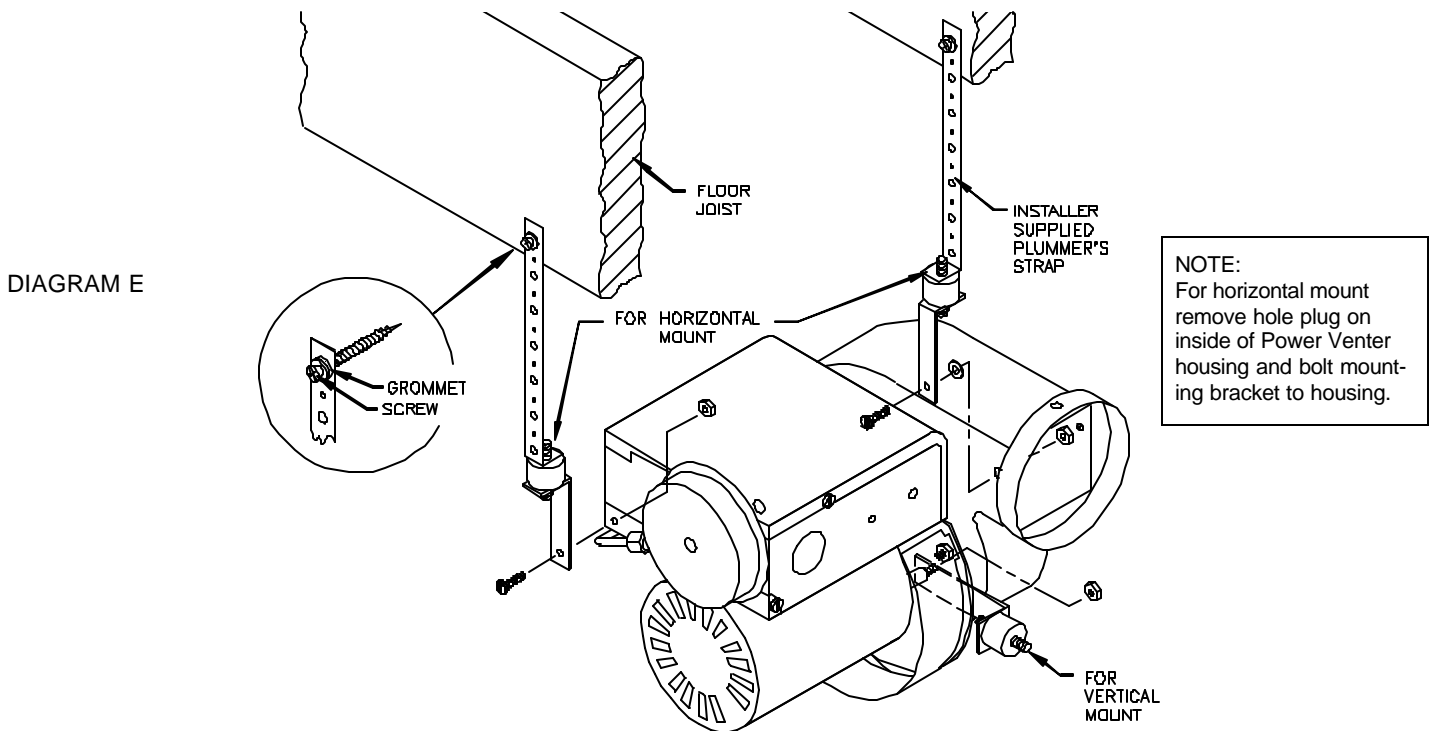

## ELECTRICAL WIRING

### INSTALLATION RESTRICTIONS:

- The installer must ensure that all electrical connections between the furnace and Power Venter are tight and that all wires are positioned and secured so they cannot come in contact with high temperature locations. Use adequate conduit supports where necessary.
- The installer must ensure that the internal furnace transformer is rated no lower than 40VA.
- The installer must ensure that, the heat anticipator in the comfort thermostat is adjusted according to the thermostat manufacturers recommendation.
- All wiring From the Power Venter to the furnace must be appropriate Class 1 wiring as follows: installed in rigid metal conduit, intermediate metal conduit, rigid non-metallic conduit, electrical metallic tubing Type MI, Type MC Cable, or otherwise be suitably protected from physical damage.
- 120V power supply to the \*GPAK-1TR\* must originate at the furnace junction box so that both appliances are on the same circuit breaker.

6. The electrical contact ratings for the Fan Proving Switch are as follows:

3 AMPS (full load) at 120VAC  
 28VA Pilot Duty (1.16 Amps) at 24VAC  
 125VA Pilot Duty at 120VAC

The Fan Proving Switch is not suitable for loads which exceed the above limitations.

7. All 24V wiring must be at least 18 AWG. All 115V wiring must be at least 14 AWG.

8. All wiring must be in compliance with local codes or in their absence, with the 1987 (or latest) Edition of the National Electric Code (NFPA #70).

9. Disconnect 115V power before attempting to wire the Power Venter to the appliance. Power may be disconnected by means of the appliance circuit breaker/fuse.

**\*GPAK-1TR\* SEQUENCE OF OPERATION:**

Adjust the furnace thermostat to call for heat. At this point, the Power Venter should start. After a delay, the furnace burner should begin a trial for ignition. When the fan proving switch closes, the furnace combustion relay is energized. Normal combustion sequence for the furnace begins: Induced draft furnace blower starts, its proving switch makes, energizing ignition control and/or gas valve. **DO NOT OPERATE THE FURNACE WITHOUT THE FAN PROVING SWITCH WIRED INTO THE 24V FURNACE CIRCUIT!**

If you are unable to wire the \*GPAK-1TR\* as outlined in these instructions, call Tjernlund's Customer Service Department toll free at 1-800-255-4208 for fast assistance.

**WIRING \*GPAK-1TR\***

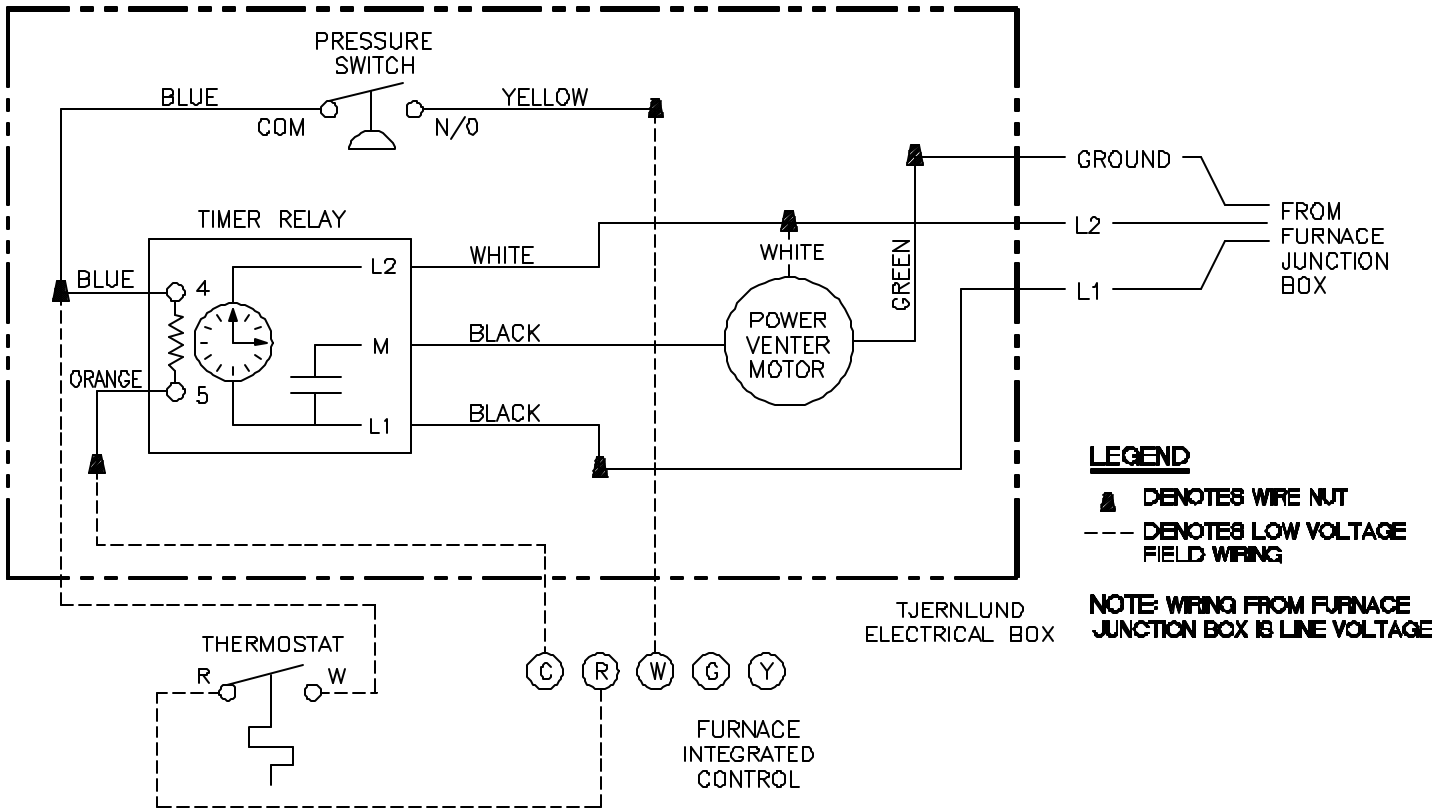

## OPERATION CIRCUIT CHECK

1. After all furnace and \*GPAK-1TR\* wiring is complete, establish 115V power to the furnace and Power Venter with the furnace thermostat not calling for heat. NOTE: The Power Venter may operate when power is first established. This is due to any time remaining on Relay/Timer "post-purge" cycle. Power Venter should shut off after approximately 45 seconds. Wait until the Power Venter shuts off before continuing.
2. Adjust the furnace thermostat to call for heat. At this point, the Power Venter should start. After a delay, the furnace burner should begin a trial for ignition. When the fan proving switch closes, the furnace combustion relay is energized. Normal combustion sequence for the furnace begins: Induced draft furnace blower starts, its proving switch makes, energizing ignition control and/or gas valve.
3. Adjust the furnace thermostat so that no heat is required. At this point the Power Venter and furnace should shut off.  
NOTE: The Power Venter will continue to run for approximately 45 seconds after the furnace shuts off.

## COMBUSTION AIR

Adequate combustion air is vital for proper combustion and for safe venting. Likewise, for proper \*GPAK-1TR\* performance, adequate combustion air must be available to the appliance. Many installers assume adequate combustion air is present, especially in older homes. In some cases this is a false assumption, because many older homes have been made "tight" due to weatherization. Size the combustion air opening(s) into the appliance room as outlined NFPA 54/NFPA 211. When installing a \*GPAK-1TR\* it is not necessary to supply any more combustion air than normally required when conventional venting.

## DRAFT ADJUSTMENT / SAFETY INTERLOCK & COMBUSTION AIR TEST

### WARNING

The Power Venter Fan Proving Switch is designed to disable the appliance gas valve upon Power Venter failure only! It is not designed and cannot replace regular vent system inspection, appliance servicing and combustion testing.

Flue gas flow adjustment **MUST** be made to ensure furnace efficiency. This should be done at the furnace exhaust outlet with a draft gauge. Draft measured between the furnace outlet and the barometric damper is to be set to -0.01" to -0.03" of water.

1. Close all doors and windows of the building. If the appliance is installed in a utility room or closet, close the entrance door to this room. Close fireplace dampers.
2. Turn on clothes dryer and all exhaust fans such as range hoods, bathroom exhausts and whole house fans to maximum speeds. (Do not operate a fan used strictly for Summer exhausting)
3. Following the appliance manufacturer's instructions, place the appliance in operation, set thermostat for continuous operation.
4. Allow fans and appliance to operate for 6 minutes.
5. Test for spillage at the barometric draft control using the flame of a match, candle or smoke from a cigarette, cigar or pipe and determine that the flame or smoke is being drawn into the barometric control, (See Diagram F).

DIAGRAM F

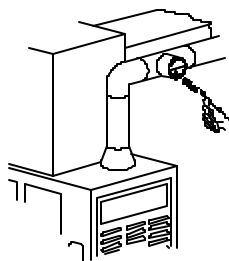

PROPER DRAFT

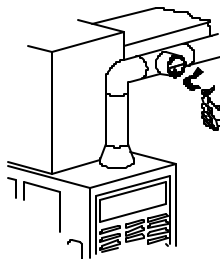

IMPROPER DRAFT

6. Sign and date these instructions to verify that the safety interlock/combustion air test was completed. These instructions must remain on premises.

SIGN: \_\_\_\_\_

DATE: \_\_\_\_\_

## MAINTENANCE

1. Oil motor every six months with 2 drops of S.A.E. #20. The oil ports are located on the top of the motor. **Magnetek motors do not need to be oiled.**
2. A vent system inspection must be performed annually by a qualified service agency. The inspection should include the operation circuit check, safety interlock test, combustion air test and a visual inspection of the complete vent system for corrosion, blockage or leaks. Any corrosion, blockage or leaks detected must be repaired or replaced immediately.

**SYMPTOM 1: POWER VENTER DOES NOT RUN DURING CALL FOR HEAT**

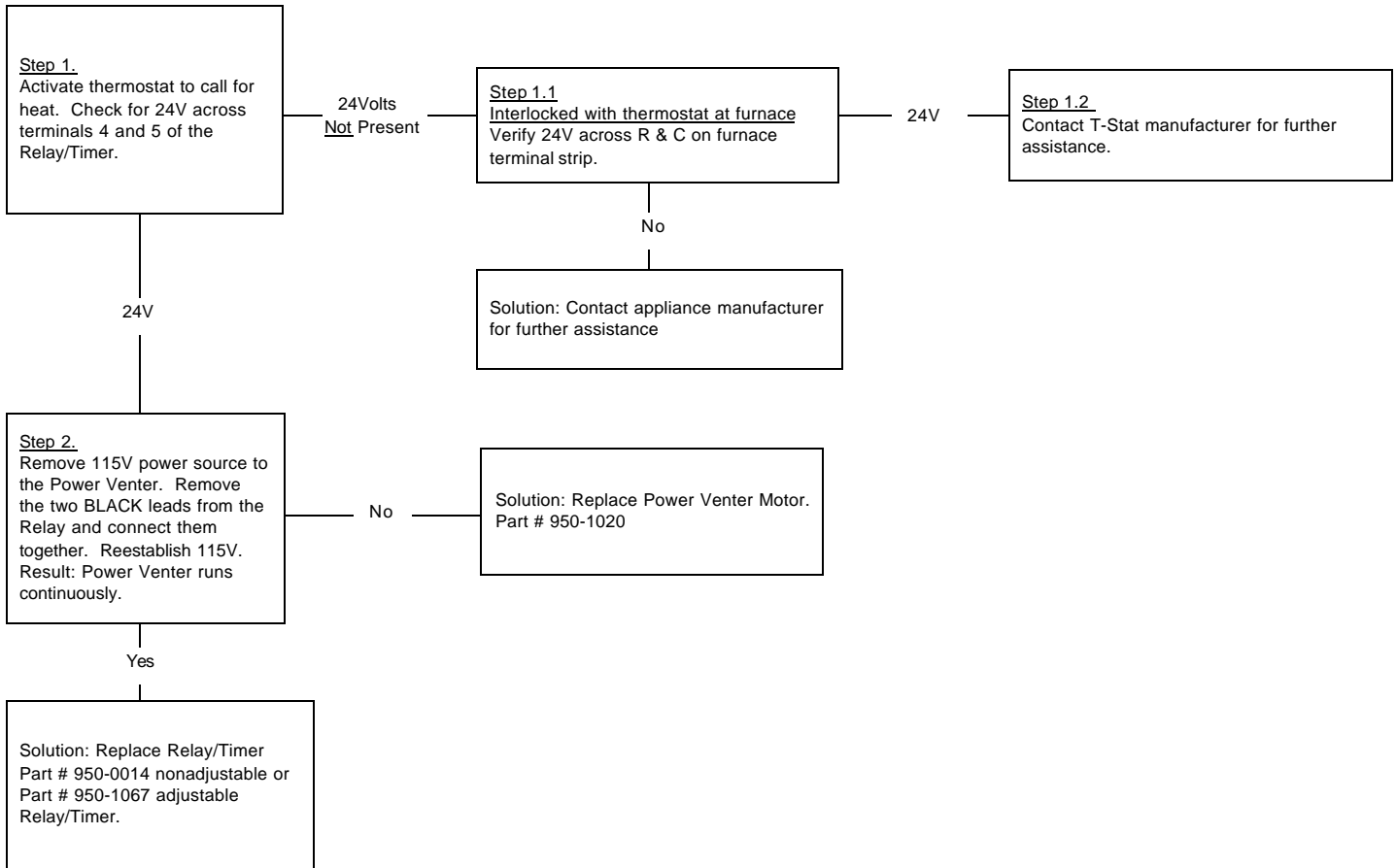

**SYMPTOM 2: POWER VENTER RUNS CONTINUOUSLY / ERRATICALLY**

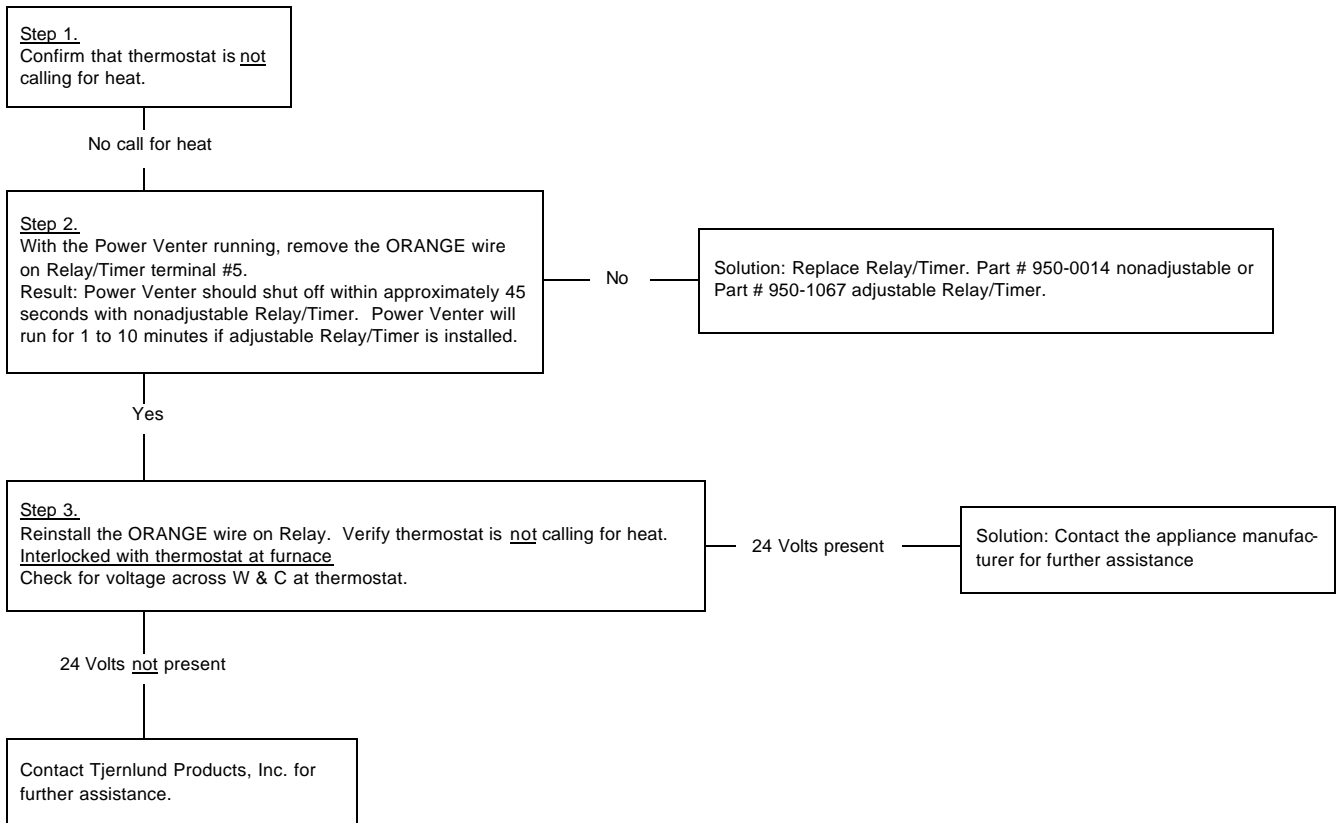

### SYMPTOM 3: POWER VENTER RUNS BUT APPLIANCE DOESN'T

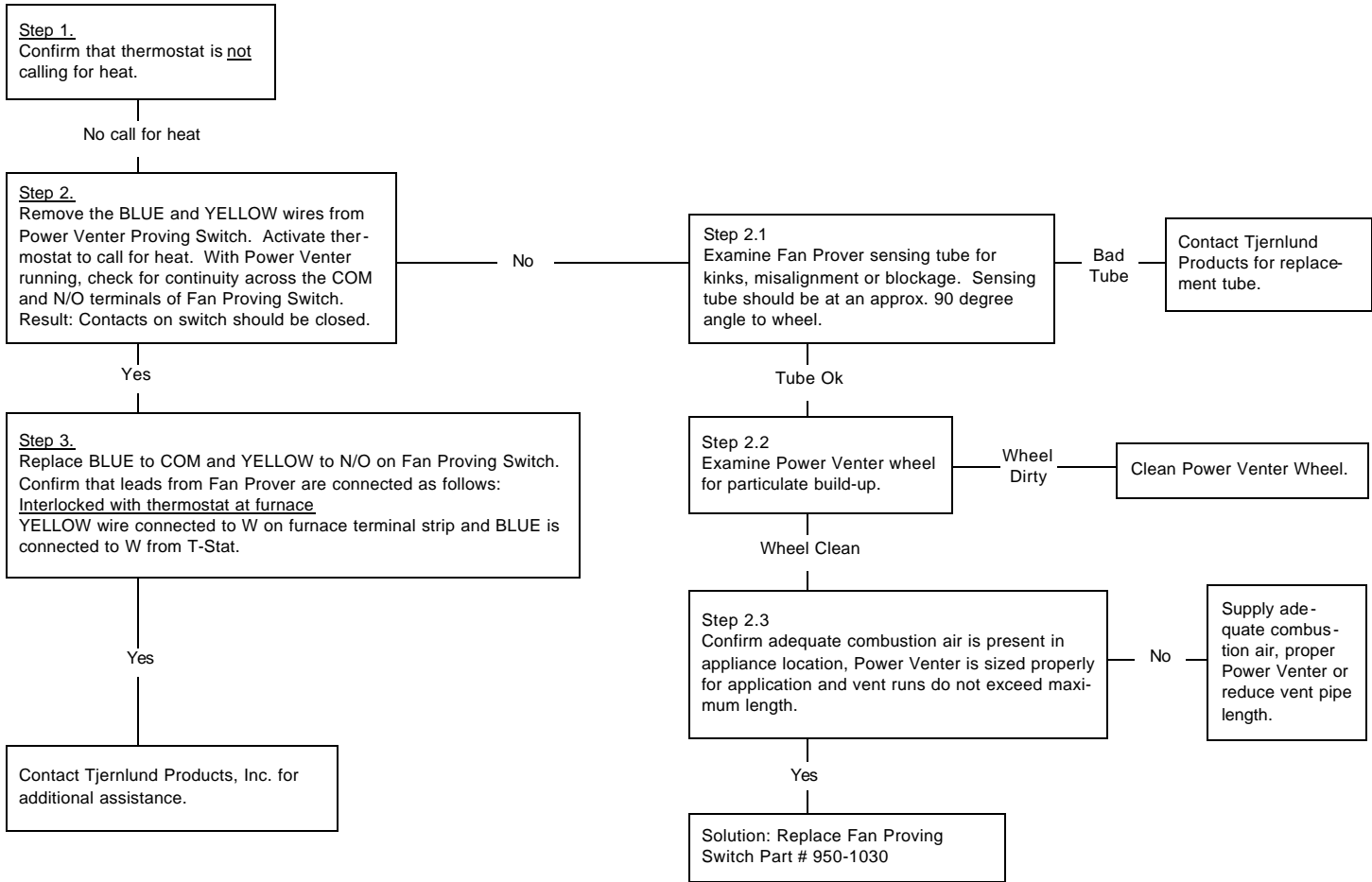

### HOW TO OBTAIN SERVICE ASSISTANCE

1. If you have any questions about your Power Venter or if it requires adjustment, repair or routine maintenance, we suggest that you contact your installer, contractor or service agency.
2. If you require technical information contact Tjernlund Products, Inc. at 1-800-255-4208.

When contacting Tjernlund Products, Inc., please have the following information available:

1. Model name of the Power Venter as shown on the label attached to Power Venter.
2. Name and address of installer and any service agency who performed work on Power Venter.
3. Date of original installation and dates any service work was performed.
4. Details of the problem as you can best describe them.

### LIMITED PARTS WARRANTY AND CLAIM PROCEDURE

Tjernlund Products, Inc. warrants the components of its products for one year from date of installation. This warranty covers defects in material and workmanship. This warranty does not cover normal maintenance, transportation or installation charges for replacement parts or any other service calls or repairs. Products that are tampered with, damaged or defective due to malfunctioning appliances are not covered under this warranty. This warranty DOES NOT cover the complete Power Venter if it is operative, except for the defective part.

Tjernlund Products, Inc. will issue credit to the original distributor or provide a free part to replace one that becomes defective during the one year warranty period. If the part is over 18 months old, proof of date of the installation in the form of the contractor sales/installation receipt is necessary to prove the unit has been in service for under one year. All receipts should include the date code of the Power Venter to ensure that the defective component corresponds with the complete unit. This will help preclude possible credit refusal.

- 1.) Follow troubleshooting guide to determine defective component. If unable to determine faulty component, contact your Tjernlund distributor or Tjernlund Products Technical Customer Service Department at 1-800-255-4208 for troubleshooting assistance.
- 2.) After the faulty component is determined, return it to your Tjernlund distributor for replacement. Please include Power Venter date code component was taken from. The date code is located on the Electrical Box coverplate. If Power Venter date code is older than 18 months you will need to provide a copy of the original installation receipt to your distributor. Credit or replacement will only be issued to a Tjernlund distributor after the defective part has been returned prepaid to Tjernlund.

### REPLACEMENT PARTS

DESCRIPTION	PART NUMBER
Vent Hood	VH1-4
Motor	950-1020
Fan Prover	950-1030
Wheel	950-1011
Relay/Timer* (approx. 45 second nonadjustable delay)	950-0014
Relay/Timer* (1 to 10 minute adjustable delay)	950-1067

\*Either Relay/Timer is suitable for the \*GPAK-1TR\*

### WHAT IS NOT COVERED

- Product installed contrary to our installation instructions
- Product that has been altered, neglected or misused
- Product that has been wired incorrectly
- Product that has been damaged by a malfunctioning or mistuned burner
- Any freight charges related to the return of the defective part
- Any labor charges related to evaluating and replacing the defective part

#### TJERNLUND LIMITED ONE YEAR WARRANTY\*

Tjernlund Products, Inc. warrants to the original purchaser of this product that the product will be free from defects due to faulty material or workmanship for a period of (1) year from the date of original purchase or delivery to the original purchaser, whichever is earlier. Remedies under this warranty are limited to repairing or replacing, at our option, any product which shall, within the above stated warranty period, be returned to Tjernlund Products, Inc. at the address listed below, postage prepaid. THERE ARE NO WARRANTIES WHICH EXTEND BEYOND THE DESCRIPTION ON THE FACE HEREOF, AND TJERNLUND PRODUCTS, INC. EXPRESSLY DISCLAIMS LIABILITY FOR INCIDENTAL OR CONSEQUENTIAL DAMAGES ARISING FROM THE USE OF THIS PRODUCT. THIS WARRANTY IS IN LIEU OF ALL OTHER EXPRESS WARRANTIES AND NO AGENT IS AUTHORIZED TO ASSUME FOR US ANY LIABILITY ADDITIONAL TO THOSE SET FORTH IN THIS LIMITED WARRANTY. IMPLIED WARRANTIES ARE LIMITED TO THE STATED DURATION OF THIS LIMITED WARRANTY. Some states do not allow limitation on how long an implied warranty lasts, so that limitation may not apply to you. In addition, some states do not allow the exclusion or limitation of incidental or consequential damages, so that above limitation or exclusion may not apply to you. This warranty gives you specific legal rights and you may also have other rights which may vary from State to State. Send all inquiries regarding warranty work to Tjernlund Products, Inc. 1601 9th Street, White Bear Lake, MN 55110-6794. Phone (651) 426-2993 • (800) 255-4208 • Fax (651) 426-9547.

\*Installations for the HTPV Corrective Action Program have a limited 5 year warranty.

### \*GPAK-1TR\* PERFORMANCE CURVE

